

DH-HAC-HFW3220EN-Z(H)

2.4Megapixel 1080P Water-proof HDCVI IR-Bullet Camera



Features

- 1/2.8" 2.4Megapixel CMOS
- 25/30@1080P, 25/30/50/60fps@720P
- High speed, long distance real-time transmission
- HD and standard definition switchable
- OSD Menu, control over coaxial cable
- DWDR, Day/Night(ICR), AWB, AGC, BLC, 3D-DNR
- Audio, Alarm, Heater(optional)
- 2.7~12mm motorized lens, Auto Iris
- Max. IR LEDs length 50m, Smart IR
- IP66, AC24V/DC12V

DH-HAC-HFW3220EN-Z(H)

Technical Specifications



Model	DH-HAC-HFW3220EN-Z(H)
Camera	
Image Sensor	1/2.8" 2.4Megapixel CMOS
Effective Pixels	1984(H)×1225(V)
Electronic Shutter	1/3s~1/100,000s
Video Frame Rate	25/30/50/60fps@720P; 25/30fps@1080P
Synchronization	Internal
Mini. Illumination	0.05Lux@F1.2(AGC ON), 0Lux IR on
Video Output	1-channel BNC HDCVI high definition video output / CVBS standard definition video output (Can switch) Tester out (1-channel BNC HDCVI high definition video output / CVBS standard definition video output)
Camera Features	
Max. IR LEDs Length	50m, Smart IR
Day/Night	Auto(ICR) / Color / B/W
Noise Reduction	2D/3D
OSD Menu	Support
Lens	
Focal Length	2.7~12mm
Angle of View	H: 105.5° ~32.9°
Lens Type	Motorized / Auto Iris
Mount Type	Φ14
Auxiliary Functions	
Alarm	1 channel in/out
Audio	1 channel in
Heater	Optional
General	
Power Supply	AC24V±10% / DC12V±10%
Power Consumption	Max 7.4W Max 13W (HFW3220E-ZH)
Working Environment	-30°C~+60°C / Less than 95%RH (no condensation) -40°C~+60°C / Less than 95%RH (no condensation) (HFW3220E-ZH)
Transmission Distance	Over 300m via 75-3 coaxial cable
Ingress Protection	IP66
Dimensions(W×D×H)	273.3mm×94.8mm×94.8mm
Weight	1.2kg
Material	Metal

DH-HAC-HFW3220EN-Z(H)

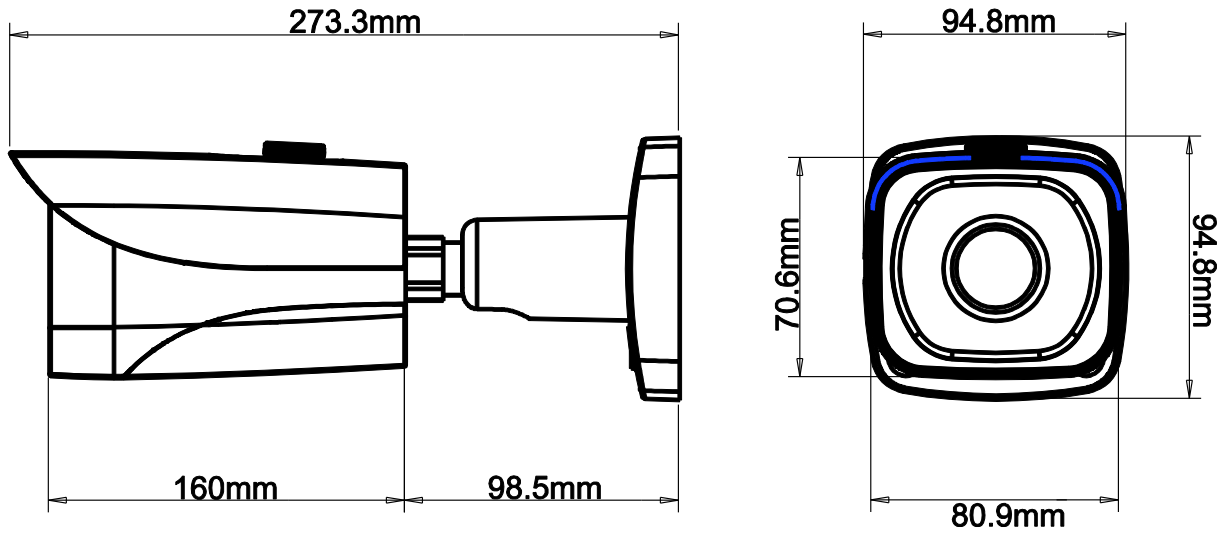
Dimensions (mm)



Accessories (optional)

		
PFA121	PFA150	PFA152

Dahua Technology USA Inc.

23 Hubble, Irvine Spectrum, CA92618, USA

Tel: +001-949 679 7777

Fax: +001-949 679 5760

Email: support.usa@dahuatech.com

www.dahuatech.us

*Design and specifications are subject to change without notice.

© 2014 Dahua Technology Co., Ltd.