

DESCRIPTION

The Verifact® CGC is an omni-directional, low impedance, electret condenser microphone with built-in preamp and automatic gain control. It can pick up normal sounds approximately 25 ft. away, or within a 50 ft. diameter circle. It's built-in limiter prevents the output signal to be overdriven thus minimizing distortion. Verifact® C-AGC produces line level output (0 dB) and can be located up to 1,000' from the Louroe base station. It is designed for mounting in a special or customized housing. The Verifact® CGC is compatible with all Louroe Audio Base Stations or Louroe Audio Interface Adapters.

NOTE:

Verifact® CGC Microphone is NOT recommended for outdoor use or in areas with high moisture content.

VERIFACT® CGC

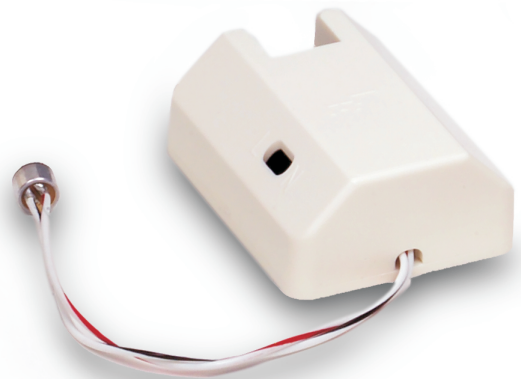

SPECIFICATIONS

Microphone Sensitivity	-45dB
Frequency response	50Hz to 8kHz
Output	Line Level (0 dB, 1 kΩ at 1 KHz)
Current drain	10 mA
Supply voltage	12 Vdc
Output gain	+10dB
Microphone housing	High impact ABS
Dimensions	2 5/8"L x 2 1/8"W x 1 1/16"H
Weight	1.5 oz
Shipping Weight	1lb

IMPORTANT NOTICE

When this equipment is used as part of an audio monitoring system, the law requires that the public be given notice of AUDIO MONITORING ON THE PREMISES. A decal notice is included with each microphone shipped.



Federal Law References:
 Federal Regulations, US Code, Title 18.
 Crime and Criminal Procedure, Sec 2510.

WARRANTY

LOUROE ELECTRONICS® warrants that at the time of shipment products manufactured by LOUROE ELECTRONICS® to be free of defects in material and workmanship. Should a defect appear within one year (12 months) from date of shipment, LOUROE ELECTRONICS will, at its sole discretion, repair or replace the defective equipment. This equipment shall not be accepted for repair or return without prior notification by LOUROE ELECTRONICS®.

This warranty does not extend to any Louroe product that has been subjected to improper or incorrect installation, misuse, accident, or in violation of installation instructions provided by LOUROE ELECTRONICS®.

Returned shipments to LOUROE ELECTRONICS® shall be at customer's expense. LOUROE ELECTRONICS® will return the equipment prepaid via best way.

INSTALLATION AND OPERATING INSTRUCTIONS

MECHANICAL INSTALLATION

Microphone pre-amp is mounted in a protective plastic housing with openings for wire connection and microphone sensitivity adjustment. If microphone is to be mounted in a special housing, a black grommet is included for optional use in securing the microphone element to the inside of a camera housing or special housing. A 1/8" minimum opening must be provided for microphone pickup. Microphone should be located within 4' to 6' of the subject. **Avoid ceiling mounts in excess of 10' in height.**

ELECTRICAL CONNECTION

Verifact® CGC Microphone will connect directly to any Louroe Base Station (AP Series or DG Series) or to the IF-1, IF-4 or IF-8 Interface Adapters. A small terminal block is located on the microphone pre-amp, and marked A, B, C:

A represents	12 Vdc (positive)
B represents	Audio (Mic output)
C represents	Ground (negative)

NOTE:

Verifact® CGC Microphone is NOT recommended for outdoor use or in areas with high moisture content.

CONNECTING VERIFACT® CGC MICROPHONE TO A LOUROE RECEIVING DEVICE (BASE STATION OR AUDIO INTERFACE ADAPTER)

After microphone connection has been made, run 2 conductor shielded cable to the Louroe Base Station or interface adapter.

If Louroe Base Station is AP Series, DG-12/25 series, IF-1, IF-4 or IF-8:

RED wire to terminal **A** of base station
BLACK wire to terminal **B** of base station
BARE wire to terminal **C** of base station

CONNECTING VERIFACT® CGC MICROPHONE DIRECTLY TO A DVR OR IP CAMERA

If a Louroe Audio Base Station or interface adapter is not used and Verifact® CGC is to be connected directly to a DVR or soundcard, etc. use the following procedure (See last page for interconnection diagram)

- 1) Apply 12 Vdc (100 mA minimum) to PC board's terminals A and C, A is positive, C is ground
- 2) Run a single conductor shielded cable 22 gauge with a 24 gauge drain wire to DVR or IP Camera
- 3) Solder on an RCA connector with wire from terminal B of microphone going to the tip of the plug, and wire from terminal C of microphone going to the sleeve of RCA plug.
- 4) Connect RCA plug into "Audio In" jack of DVR or soundcard.

NOTE: In the interconnection diagram, black wire is used instead of bare to represent ground.

If DVR's audio input is 3.5mm (1/8"port), a 3.5mm adapter must be connected to one end of the RCA cable. Check DVR manufacturer's instructions to determine if 3.5mm audio input is mono or stereo.

INSTALLATION AND OPERATING INSTRUCTIONS

INTERCONNECTION DIAGRAM

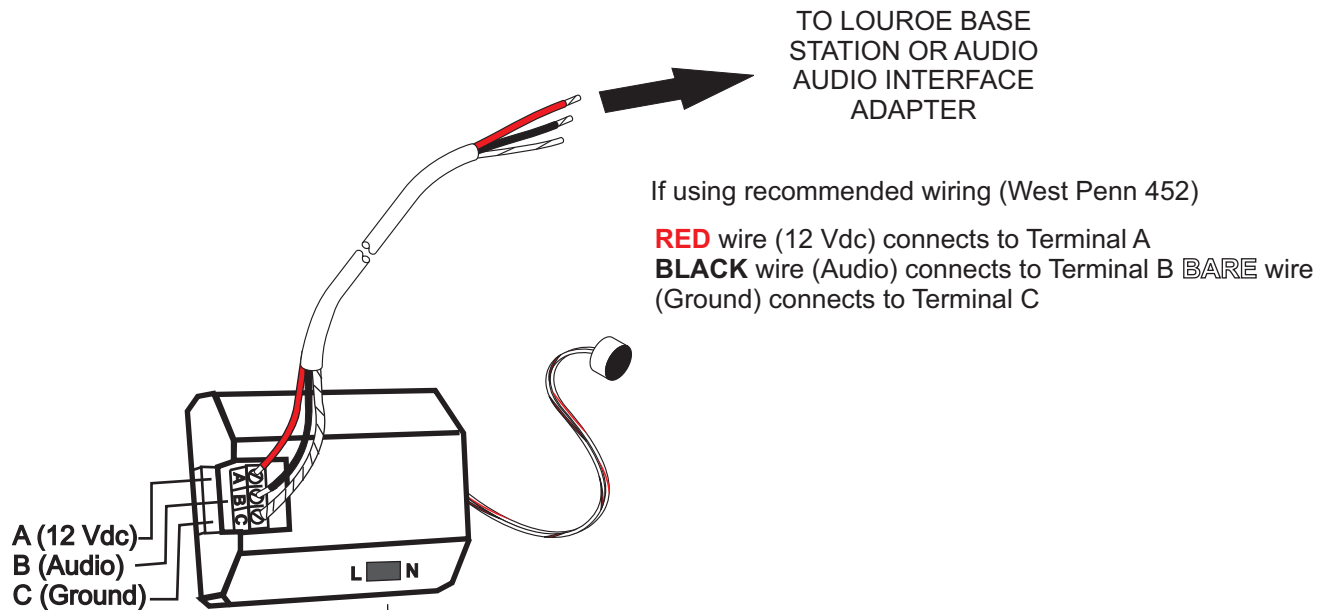

MICROPHONE GAIN ADJUSTMENT

The microphone has an audio output gain potentiometer. Microphone is always shipped with a 0dB output. If it's necessary to change the gain of the microphone, insert a small screwdriver into the potentiometer rotate clockwise to increase or counterclockwise to decrease. Maximum gain is +10dB

WIRING REQUIREMENTS

2 Conductor **shielded** cable, 22 gauge with a 24 gauge drain wire

NOTE: Unshielded cable is not satisfactory for audio systems

West Penn 452 or equivalent



INSTALLATION TIPS

1. Use overall shielded audio cable only. West Penn 452, Belden 8451 or equivalent. **UNSHIELDED CABLE IS NOT SATISFACTORY FOR SOUND SYSTEMS.**
2. When used at a cash register checkout, microphone should be installed closer to the customer rather than the cash register, as the drawer sound could dominate the recording. It should be installed closest to the area to be monitored and documented.
3. Avoid installing microphone near air vents, air conditioners, fans and other equipment that generate high sound and air pressure.
4. If microphone is installed in a police interview room, room should be conditioned with any type of carpeting, acoustical ceiling tiles, acoustical foam, etc. to reduce echo. This will enhance the quality of live and recorded audio.
5. The APR-1 and microphone should have a barrier or solid wall between them in order to avoid audio feedback, especially when they are in close proximity to each other. If no barrier, microphone should be at least 25' from APR-1 to avoid acoustical feedback.

INSTALLATION AND OPERATING INSTRUCTIONS

CONNECTING A LOUROE MICROPHONE DIRECTLY TO AN IP CAMERA, ENCODER OR DVR WITH 3.5mm MONO AUDIO INPUT

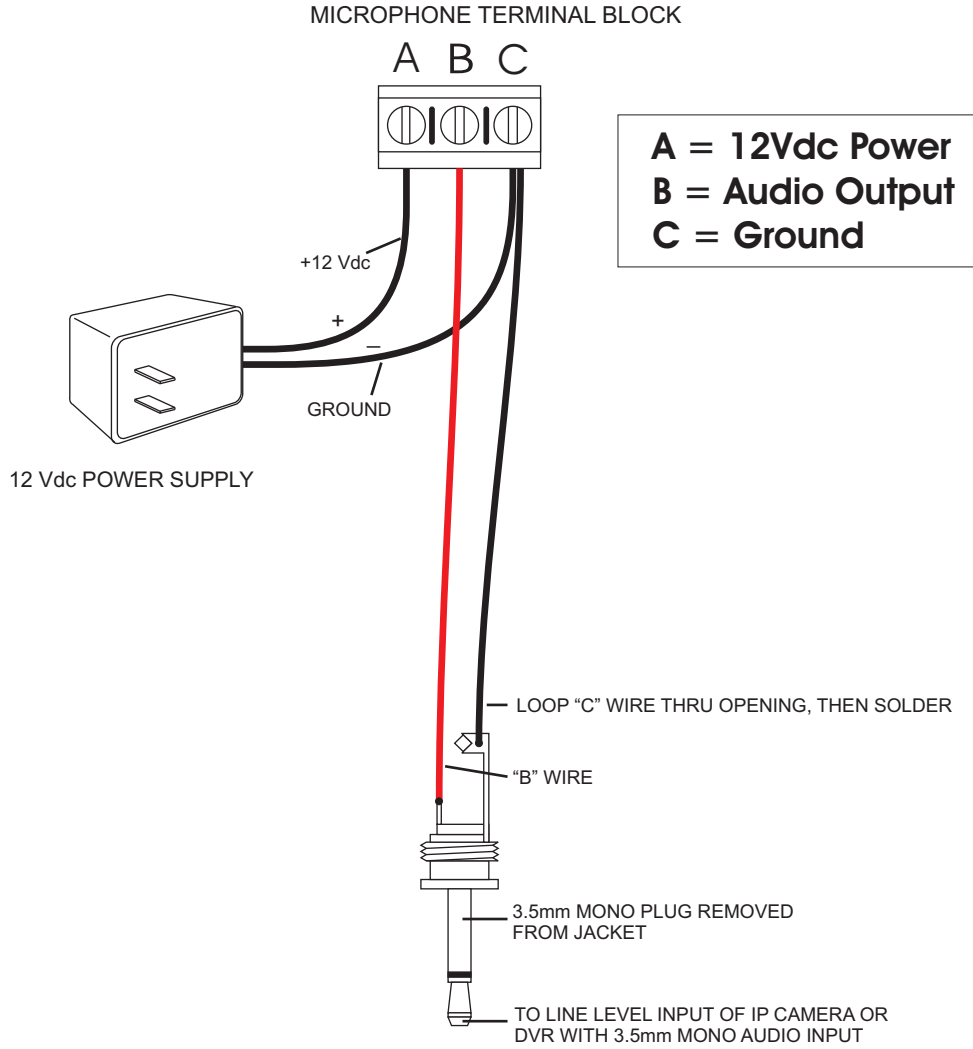

OTHER PLUGS WIRING CONFIGURATION

