

AUTODOME IP starlight 7000 HD

www.boschsecurity.com



BOSCH
Invented for life



- ▶ Excellent low-light performance
- ▶ High Dynamic Range (120 dB) for challenging bright and dark scenes
- ▶ Built-in Intelligent Video Analytics to trigger relevant alerts and quickly retrieve data
- ▶ Enhanced camera reliability with optional dual, redundant power ensures continuous 24x7 operation
- ▶ Dedicated AES 256-bit crypto engine for secure recorded video

The AUTODOME IP starlight 7000 HD is a high-speed PTZ dome camera that delivers unmatched picture quality and network performance day and night. The camera has superb high-definition (HD) 1080p25/30 video and 30x optical zoom. Easy to install, the camera is available in either a field-proven, indoor/outdoor pendant housing or an indoor, in-ceiling housing. The camera provides complete network-based control of all dome functionality including pan/tilt/zoom operation, presets, tours and alarms as well as web-based configuration of all dome settings. It also provides direct network video streaming using H.264 compression / bandwidth throttling to efficiently manage bandwidth and storage requirements while delivering outstanding image quality.

Functions

Exceptional low-light performance

The latest sensor technology combined with the sophisticated noise suppression results in an exceptional sensitivity in color. The low-light performance is so good that the camera continues to provide excellent color performance even with a minimum of ambient light.

Intelligence

With built-in video content analysis (VCA), the camera reinforces the Intelligence-at-the-Edge concept where edge devices become increasingly intelligent. The camera comes with the state-of-the-art VCA method by Bosch, Intelligent Video Analytics, that reliably detects, and analyzes moving objects while suppressing unwanted alarms from spurious sources in the image.

With this method, the camera is able to detect idle and removed objects as well as loitering, multiple line crossing, and trajectories. This method also supports BEV (Bird's Eye View) People counting.

Intelligent Tracking

The camera utilizes the built-in Intelligent Video Analytics to follow an individual or an object continuously.

When Intelligent Video Analytics detects objects while the camera is in a stationary position, the camera activates the Intelligent Tracking feature. This feature controls the pan/tilt/zoom actions of the camera to track the objects and keep them in view in the scene. The new Intelligent Tracking is based on robust flow detection algorithms which can reliably track moving objects even under challenging scenes.

The tracking and detection reliability can be enhanced further with virtual masking for scenes with a lot of background motion such as trees or other objects creating constant motion in the scene.

The camera supports three modes for Intelligent Tracking:

Auto mode: When configured in this mode, the camera actively analyzes the video to detect any moving object. If it detects movement, it begins to track the object. This mode is most useful for scenarios where normally no motion is expected.

One Click mode: In this mode, users can click an object moving in the live video image to enable the camera to track the movement of the selected object. This mode is most useful for scenarios where normal scene activity is expected.

Triggered mode: In this mode, the camera continuously analyzes the scene for alarms or rule violations. If a rule is violated, it triggers the advanced tracking feature of the camera to start following the object / person that triggered the alarm.

This unique combination of robust Intelligent Video Analytics and Intelligent Tracking allows the camera to track moving objects of interest without getting distracted by other moving objects in the scene.

Virtual masking

The camera offers Virtual Masking, which gives users flexibility to mask parts of the scene which should not be considered for flow analysis to trigger Intelligent Tracking. This allows users to mask from Intelligent Video Analytics/Tracking any background motion (moving trees, pulsating lights, and busy roads) in the scene without blocking the motion from the video.

Dual power options

All AUTODOME starlight models can be powered by either a PoE+ (IEEE 802.3at)-capable network switch or a High PoE midspan.

In a PoE configuration, a single cable connection provides power while simultaneously supporting data and video transmission.

For additional system reliability, users can connect 24 VAC power and PoE to provide fully redundant power to the camera without disruption to operation.

DORI coverage

DORI (Detect, Observe, Recognize, Identify) is a standard system (EN-62676-4) for defining the ability of a camera to distinguish persons or objects within a covered area. The maximum distance at which a camera/lens combination can meet these criteria is shown below:

	DORI definition	Distance WIDE 1X	TELE 30X
Detect	25 px/m (8 px/ft)	62 m (193 ft)	1913 m (5978 ft)
Observe	63 px/m (19 px/ft)	25 m (81 ft)	759 m (2517 ft)

	DORI definition	Distance WIDE 1X	TELE 30X
Recognize	125 px/m (38 px/ft)	12 m (41 ft)	383 m (1259 ft)
Identify	250 px/m (76 px/ft)	6 m (20 ft)	191 m (629 ft)

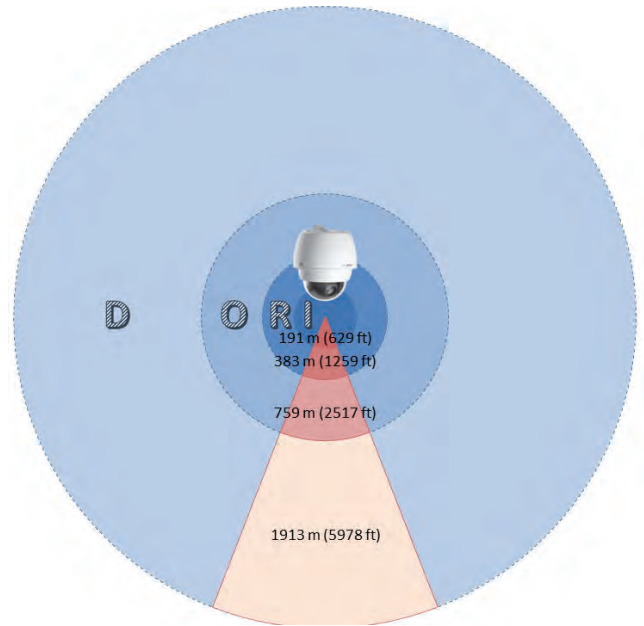

Five (5) pre-programmed user modes

Five pre-programmed but configurable user modes, optimized with the best settings for a variety of typical applications, make on-site programming easy and user-friendly. Users select from the menu the mode that best defines the environment in which the camera is installed:

- Outdoor – General day-to-night changes with sun highlights and street lighting
- Indoor – Ideal mode for indoor applications where lighting is constant and not changing
- Low light – Optimized for sufficient details at low light
- Motion – Monitoring traffic or fast moving objects; motion artifacts are minimized
- Vibrant – Enhanced contrast color reproduction and sharpness

Users have the ability to customize these modes, if necessary, for the specific requirements of the site.

Image Stabilization

As PTZ cameras continue to increase their optical zoom capabilities, image stabilization becomes critical to eliminate movement caused by unstable camera mounts. Minor movement of the camera mount can shift the field of view by a large distance when the camera is zoomed to a high value. This can render images unusable. The camera incorporates an Image Stabilization algorithm that allows the camera to detect continuous vibration. If it detects vibration, the

camera dynamically corrects the shaky video in both the vertical and horizontal axis, resulting in exceptional image clarity and a stable field of view on the monitor.

Superior privacy masking

The camera provides 24 individual, easy to configure privacy masks, with up to 8 displayed in the same scene. As the camera is zoomed, each mask changes size smoothly and quickly, ensuring that the covered object cannot be seen in most cases.

Sophisticated alarm responses

The camera supports advanced alarm control that uses sophisticated rules-based logic to determine how to manage alarms. In its most basic form, a “rule” could define which input(s) should activate which output(s). In a more complex form, inputs and outputs can be combined with pre-defined or user-specified commands to perform advanced camera functions.

PTZ drive and mechanism

The AUTODOME 7000 supports 256 pre-positions and two styles of Guard Tours: Preset and Record/Playback. Users can configure the preset standard tour with as many as 256 sequential pre-positions, with a configurable dwell time between pre-positions. The AUTODOME Series also provides support for two recorded tours, which are recorded macros of an operator’s movements, including pan, tilt, and zoom activities, and can be played back with the click of a button.

Pan and tilt preset repeatability are accurate to within ± 0.1 degrees to ensure that the correct scene is captured every time. The camera delivers variable pan/tilt speeds from a crawl speed of only 0.1 degrees per second to a full 400 degrees per second. The camera is capable of pan speeds of 400 degrees per second and tilt speeds of 300 degrees per second between pre-positions. The camera provides a tilt angle 18 degrees above the horizon, and a pan range of up to 360 degrees continuous rotation.

Content Based Imaging Technology

Content Based Imaging Technology (CBIT) is used to radically improve image quality in all lighting conditions and to identify areas for enhanced processing. The camera examines the scene using intelligent video analytics and provides feedback to re-tune the image processing. This provides better detail in the areas that matter and better all-round performance.

Intelligent Defog

Users can configure the mode to be active continuously, or to activate automatically when the video analytics in the camera detect fog and add light to the video image (and then deactivate when the fog clears or the scene changes).

Intelligent Dynamic Noise Reduction reduces bandwidth and storage requirements

The camera uses Intelligent Dynamic Noise Reduction which actively analyzes the contents of a scene and reduces noise artifacts accordingly.

The low-noise image and the efficient H.264 compression technology provide clear images while reducing bandwidth and storage by up to 50% compared to other H.264 cameras. This results in reduced-bandwidth streams that still retain a high image quality and smooth motion. The camera provides the most usable image possible by cleverly optimizing the detail-to-bandwidth ratio.

Bitrate optimized profile

The average typical optimized bitrate in kbits/s for various frame rates is shown in the table:

FPS	1080p	720p	480p
60	--	2600	2000
30	2600	1300	1000
15	2100	1100	800
10	1800	1000	700
5	1250	600	450
2	500	270	200

Actual bitrate may vary depending on the scene complexities and encoding configurations.

Common product platform (CPP4)

The camera has an advanced, efficient H.264 encoder (CPP4) embedded for high quality HD streaming video and very efficient streaming and network capabilities. The new platform supports simultaneous streaming of individually configurable HD streams, and allows a choice of HD resolution in combination of SD resolutions.

Advanced streaming

The camera offers advanced streaming capabilities so that you can configure the camera to take advantage of the latest network technology.

The camera is designed on the most efficient and powerful H.264 encoding platform capable of delivering high-quality HD video with very low network load. The new intelligent encoding capabilities drops the bandwidth consumption to extremely low levels if the camera detects no motion in the scene.

The camera is capable of quad streaming which allows the camera to be configured to deliver independent, configurable streams for live viewing, recording, or remote monitoring on constrained bandwidths.

Recording and storage management

A memory card (SD (Secure Digital), SDHC (Secure Digital High Capacity), or SDXC (Secure Digital eXtended Capacity)) can be used for local alarm recording or for Automatic Network Replenishment (ANR) to improve the overall recording reliability.

Recording management can be controlled by the Bosch Video Recording Manager (VRM), or the camera can use iSCSI targets directly without any recording software.

ONVIF conformant

The camera conforms to the ONVIF (Open Network Video Interface Forum) specification which guarantees interoperability between network video products regardless of manufacturer. The ONVIF Profile S specification allows easy integration with other conformant devices and VMS. ONVIF conformant devices are able to exchange live video, audio, metadata, and control information, and ensure that they are automatically discovered and connected to network applications such as video management systems.

Data security

Special measures have been put in place to ensure the highest level of security for device access and data transport. The three-level password protection with security recommendations allows users to customize device access. Web browser access can be protected using HTTPS and firmware updates can also be protected with authenticated secure uploads. The on-board Trusted Platform Module (TPM) and Public Key Infrastructure (PKI) support, guarantee superior protection from malicious attacks. The 802.1x network authentication with EAP/TLS, supports TLS 1.2 with updated cipher suites including AES 256 encryption.

The advanced certificate handling offers:

- Self-signed unique certificates automatically created when required
- Client and server certificates for authentication
- Client certificates for proof of authenticity
- Certificates with encrypted private keys

Ease of installation and servicing

The camera has been designed for quick and easy installation, a key feature from Bosch IP video products. All housings feature recessed screws and latches for increased tamper resistance.

Indoor/outdoor pendant housings are rated to provide IP66 protection and offer an operating temperature range down to -40 °C (-40 °F). The indoor/outdoor pendant comes fully assembled with a sunshield which can be easily removed for use in indoor applications. In addition, both pendant and in-ceiling camera models have a high-resolution acrylic bubble for enhanced image clarity.

Bosch offers a full complement of hardware and accessories (sold separately) for wall, corner, mast, roof, pipe mount, and in-ceiling applications for indoor and outdoor environments, which allow the camera to be adapted easily to individual site requirements. Remotely upgrade the camera whenever new firmware becomes available. This ensures up-to-date products, thus protecting investment with little effort.

Fiber Optic Kit

Bosch offers the optional VG4-SFP SCKT, a unique media converter module for use with various Bosch devices. This media converter module is designed to accept a wide-range of 10/100 Mbps SFP modules for use with Multimode or Single-mode optical fiber with LC or SC connectors.

The media converter module along with the SFP module is user-installed directly into the camera's power supply box to provide an integrated fiber optic solution.

Unsurpassed reliability

As with all Bosch products, the camera is designed using the industry's best design process and is subjected to the most stringent testing standards such as HALT (highly accelerated life testing), which pushes the limits of products to ensure reliability throughout their lifetime.

Certifications and approvals

HD standards

- Complies with the SMPTE 274M-2008 Standard in:
 - Resolution: 1920x1080
 - Scan: Progressive
 - Color representation: complies with ITU-R BT.709
 - Aspect ratio: 16:9
 - Frame rate: 25, 30, 50 and 60 frames/s
- Complies with the 296M-2001 Standard in:
 - Resolution: 1280x720
 - Scan: Progressive
 - Color representation: complies with ITU-R BT.709
 - Aspect ratio: 16:9
 - Frame rate: 25, 30, 50 and 60 frames/s

Electromagnetic Compatibility (EMC)	Complies with FCC Part 15, ICES-003, and CE regulations, including latest versions of EN 50130-4, EN 55022:2006 inc. AL:2007, EN 61000-3-3, EN 61000-6-1, EN 61000-6-2, and EN 50121-4 (Railway applications)
Product Safety	Complies with UL, CE, CSA, EN, and IEC Standards 60950-1 & 22
Environmental	In-ceiling: IP54, Plenum rated (with acrylic bubble) IK10 rating when using optional bubble VGA-BUBBLE-IK10 (sold separately) Indoor/Outdoor Pendant: IP66, NEMA 4X
ONVIF Conformance	EN 50132-5-2

**Notice**

Conformity to EN 50130-4
One of the following power supply units is required to conform to the EN 50130-4 standard: VG4-A-PSU0, VG4-A-PSU1, VG4-A-PSU2, VG4-A-PA0, VG4-A-PA1, or VG4-A-PA2.

Region	Certification	
Europe	CE	Declaration of Conformity (DoC) - AUTODOME 7000
USA	UL	AUTODOME 7000

Technical specifications**AUTODOME IP starlight 7000 HD camera**

Imager	1/2.8-type Exmor R CMOS sensor
Effective Picture Elements (Pixels)	1945 x 1097 (2.13 MP)
Lens	30x Zoom 4.3 mm to 129 mm F1.6 to F4.7
Field of View (FOV)	2.3° to 63.7°
Focus	Automatic with manual override
Iris	Automatic with manual override
Digital Zoom	12x

Video performance - Sensitivity

(3100K, reflectivity 89%, 1/30, F1.6, 30 IRE)

Color	0.0077 lx
Mono	0.0008 lx

Additional Camera Settings

Gain control	AGC, Fixed
Aperture Correction	Horizontal and vertical
Electronic Shutter Speed (AES)	1/1 sec to 1/10000 sec (22 steps)
Signal-to-Noise Ratio (SNR)	>55 dB
Backlight compensation (BLC)	On, Off
White balance	2000 K to 10,000 K ATW, AWB Hold, Extended ATW, Manual, Sodium Lamp Auto, Sodium Lamp
Day/Night	Monochrome, Color, Auto
Intelligent defog	Improves visibility when viewing foggy or other low-contrast scenes.

Dynamic range

High Dynamic Range (HDR) Mode	120 dB WDR
-------------------------------	------------

Mechanical

	In-Ceiling	Pendant
Pan Range	360° cont.	360° cont.
Tilt Angle	1° above horizon	18° above horizon
Pre-position Speed	Pan: 400°/s Tilt: 300°/s	Pan: 400°/s Tilt: 300°/s

Pan/Tilt Modes

• Turbo Mode (Manual Control)	Pan: 0.1°/s – 400°/s Tilt: 0.1°/s – 300°/s	
• Normal Mode	0.1°/s-120°/s	0.1°/s-120°/s
Preset Accuracy	± 0.1° typ.	± 0.1° typ.

Electrical

	In-Ceiling	Pendant
Input Voltage	21-30 VAC, 50/60 Hz; (class II) High PoE (with Bosch Midspan (NPD-6001A); required to power the heater) PoE+ (IEEE 802.3at, class 4 standard) (when used indoors, not powering the heater)	
Power Consumption, typical	24 W / 44 VA	60 W / 69 VA (heaters on) or 24 W / 44 VA (heaters off / without heater connected in power supply box for indoor applications)

Surge Suppression

Protection on Alarm Inputs	Peak current 17 A, peak power 300 W (8/20 µs)
Protection on Alarm Outputs	Peak current 2 A, peak power 300 W (8/20 µs)
Protection on Relay Output	Peak current 7.3 A, peak power 600 W (10/1000 µs)
Protection on Power Input (Dome)	Peak current 7.3 A, peak power 600 W (10/1000 µs)
Protection on Power Output (Arm Power Supply)	Peak current 21.4 A, peak power 1500 W (10/1000 µs)
10/100 Ethernet Data Lines	Peak current 14 A, peak power 200 W (8/20 µs)

Software Control

Camera Setup/ Control	Via web browser (such as Internet Explorer version 7.0 or later), Bosch Configuration Manager, Bosch Video Management System (BVMS), Bosch Recording Station (BRS), or Bosch Video Client (BVC)
Software Update	Network firmware upload

Network

Communications Protocols	Standard Bosch IP protocol, including ONVIF and SNMP v1
Standards / Video compression	H.264 (ISO/IEC 14496-10), M-JPEG, JPEG
Streaming	Four (4) streams with individually configurable frame rate and resolution: <ul style="list-style-type: none"> • Two (2) independently configurable H.264 recording streams • Two (2) non-recording streams (profiles)

Note: The options available for Stream 1 depend on the value in the **Max. frame rate** field in the Installer Menu in camera configuration.

When the option in field "Property" for Stream 1 is:	The available options in field "Property" for Stream 2 are:
H.264 MP SD	- H.264 MP SD
H.264 MP 720p fixed	- H.264 MP SD - H.264 MP 720p fixed - H.264 MP 400x720 upright (cropped) - H.264 MP D1 4:3 (cropped) - H.264 MP 1280x960 (cropped) - H.264 MP 640x480
H.264 MP 1080p fixed	- Copy Stream 1 - H.264 MP SD - H.264 MP 720p8/10 fixed - H.264 MP 1080p4/5 fixed - H.264 MP 400x720 upright (cropped) - H.264 MP D1 4:3 (cropped) - H.264 MP 640x480
H.264 MP 720p50/60 fixed	- Copy Stream 1 - H.264 MP SD - H.264 MP 720p6/7 fixed - H.264 MP 400x720 upright (cropped) - H.264 MP D1 4:3 (cropped) - H.264 MP 640x480
Non-recording profiles	Two (2) streams, I-frame only Options are: - HD Image Optimized - HD Balanced - HD Bit Rate Optimized - SD Image Optimized - SD Balanced

- SD Bit Rate Optimized
- DSL Optimized
- 3G Optimized

Resolution (H x V)	
1080p HD	1920 x 1080 (16:9)
720p HD	1280 x 720
432p SD	768 x 432
288p SD	512 x 288
144p SD	256 x 144
Protocols	IPv4, IPv6, UDP, TCP, HTTP, HTTPS, RTP/RTCP, IGMP V2/V3, ICMP, ICMPv6, RTSP, FTP, Telnet, ARP, DHCP, APIPA (Auto-IP, link local address), NTP (SNTP), 802.1x, DNS, DNSv6, DDNS (Dyn.com, selfHOST.de, no-ip.com), SMTP, iSCSI, UPnP (SSDP), DiffServ (QoS), LLDP, SOAP, Dropbox, CHAP, digest authentication
Ethernet	10BASE-T/100BASE-TX, auto-sensing, half/full duplex
Encryption	TLS 1.0, SSL, DES, 3DES, AES
Ethernet connector	RJ45
Connectivity	ONVIF Profile S, Auto-MDIX
GOP Structure	IP, IBP, IBBP
Data Rate	9.6 kbps to 6 Mbps
Overall IP Delay	240 ms (typical)
Audio	
- Standard	G.711, 8 kHz sampling rate L16, 16 kHz sampling rate AAC, 16 kHz sampling rate
- Signal-to-Noise Ratio	>50 dB
- Audio Streaming	Bidirectional (full-duplex)
Local Storage	
Memory Card Slot	User-supplied SD/SDHC/SDXC memory card (maximum 2TB – SDXC)
Recording	Continuous recording of video and audio, alarm/events/schedule recording

Fiber Optic Kit

VG4-SFPSCKT

Description	Fiber Optic Ethernet Media Converter kit ⁶ . Requires a small form-factor pluggable (SFP) module (sold separately).
Data Interface	Ethernet
Data Rate	10/100 Mbps IEEE 802.3 Compliant Full Duplex or Half Duplex Electrical Port Full Duplex Optical Port
Compatible Receiver	CNFE2MC
Installation	Installed inside a VG4-A-PA0, VG4-A-PA1, VG4-A-PA2, VG4-A-PSU1, or a VG4-A-PSU2 power supply box with supplied mounting hardware

6. Kit available separately and must be installed inside the AUTODOME power supply box.

SFP Modules

Description	Interchangeable modules available for use with MMF or SMF optical fiber.
Data Interface	Ethernet
Data Rate	10/100 Mbps IEEE 802.3 Compliant
Weight (all SFP modules)	0.23 kg (0.05 lb)
Dimensions (LxWxH)	SFP-2, SFP-3: 55.5 x 13.5 x 8.5 mm (2.2 x 0.5 x 0.3 in.) SFP-25, SFP-26: 63.8 x 13.5 x 8.5 mm (2.5 x 0.5 x 0.3 in.)

	Type	Connector	Wavelength (transmit / receive)	Max. Distance
SFP-2	MMF	Duplex LC	1310 nm / 1310 nm	2 km (1.2 miles)
SFP-3	SMF	Duplex LC	1310 nm / 1310 nm	20 km (12.4 miles)
SFP-25	MMF	Single SC	1310 nm / 1550 nm	2 km (1.2 miles)
SFP-26	MMF	Single SC	1550 nm / 1310 nm	2 km (1.2 miles)

Fiber Compatibility

Optical Fiber Compatibility, MMF	50/125 µm MMF. For 50/125 µm fiber, subtract 4 dB from the specified optical budget value. Must meet or exceed fiber standard ITU-T G.651.
----------------------------------	--------------------------------------------------------------------------------------------------------------------------------------------

Optical Fiber Compatibility, SMF	8–10/125 µm SMF. Must meet or exceed fiber standard ITU-T G.652.
Optical Distance Specifications	Specified transmission distances are limited to the optical loss of the fiber and any additional loss introduced by connectors, splices, and patch panels. The modules are designed to operate over the entire optical loss budget range, so they do not require a minimum loss in order to operate.

Miscellaneous

Sectors / Title	16 independent sectors with 20 characters per title
Privacy Masks	24 individually configurable privacy masks (Available options: Gray, Mosaic)
Virtual Masks	24 individually configurable masks to hide parts of the scene (background motion such as moving trees, pulsating lights, busy roads, etc.) which should not be considered for flow analysis to trigger Intelligent Tracking.
Pre-positions	256, each with 20 characters per title
Guard Tours	Two (2) types of tours: <ul style="list-style-type: none"> Recorded tours - two (2), maximum total duration 30 minutes (depending on amount of commands sent during recording) Preset tour - one (1), consisting of up to 256 scenes consecutively, and (1) customized up to 64 scenes
Supported Languages	English, Czech*, Dutch, French, German, Italian, Polish, Portuguese, Russian*, Spanish, Japanese, Chinese * Available with separate language upload

User Connections

Power, Camera	RJ-45 10/100 Base-TX Ethernet (High Power-over-Ethernet (High PoE)) or PoE+ (IEEE 802.3at, class 4 standard) 21-30 VAC, 50/60 Hz
Power, Heater	RJ-45 10/100 Base-TX Ethernet (High Power-over-Ethernet (High PoE)) 21-30 VAC, 50/60 Hz
Video and Control	RJ-45 10/100 Base-TX Ethernet
Alarm Inputs (7)	2 supervised, 5 non-supervised Programmable for "normally open" or "normally closed"
Alarm Outputs (4)	1 dry contact relay, 3 open collector/transistor outputs 32 VDC @ 150 ma max.
Audio	1 x mono line in, 1 x mono line out

Signal line in	12 kOhm typical, 1 Vrms max
Signal line out	1 Vrms at 1.5 kOhm, typical

Environmental

	In-Ceiling (with acrylic bubble)	Pendant (with acrylic bubble)
Ingress Protection Rating/ Standard	IP54, Plenum rated	IP66, NEMA 4X
Operating Temperature (with heater wired)	-10 to +40 °C (+14 to +104 °F)	-34 to +74 °C (-30 to +165 °F) (in accordance with NEMA TS 2-2003 (R2008), section 2.1.5.1) -40 to +55 °C (-40 to +131 °F) (continuous operation)
Operating Temperature (without heater wired)		-10 to +55 °C (+14 to +131 °F) (continuous operation)
Storage Temperature	-40 to +60 °C (-40 to +140 °F)	-40 to +60 °C (-40 to +140 °F)
Operating Humidity	0% to 90% RH, non-condensing	0% to 100% RH, condensing ⁷

⁷ For outdoor pendants only, condensing humidity implies moisture can condense to water droplets.

Note: TS2 conformance applies to outdoor models only.

Construction

Dimensions	See dimensional drawings.
Weight	In-ceiling: 2.59 kg (5.71 lb) Indoor/Outdoor Pendant: 3.07 kg (6.77 lb)
Bubble Size	153.1 mm diameter (6.03 in.)
Construction Material, Housing	In-ceiling: Magnesium Pendant: Cast aluminum
Construction Material, Bubble	In-ceiling: HD High-resolution acrylic Pendant: High-resolution acrylic
Standard Color	White (RAL 9003)
Standard Finish	Powder coated, sand finish

Mounts/Accessories

Bubbles

In-ceiling

Clear HD high-resolution acrylic	VGA-BUBHD-CCLA
----------------------------------	----------------

Tinted HD high-resolution acrylic (Included with in-ceiling camera models.)	VGA-BUBHD-CTIA
--------------------------------------------------------------------------------	----------------

Pendant

Clear high-resolution acrylic (Included with pendant camera models.)	VGA-BUBBLE-PCLA
Tinted high-resolution acrylic	VGA-BUBBLE-PTIA
Clear rugged IK10-rated nylon*	VGA-BUBBLE-IK10

Mounts

Pendant Arm Mounts	
Wall Arms	VG4-A-PA0 (no transformer) VG4-A-PA1 (120 VAC transformer) VG4-A-PA2 (230 VAC transformer)
Pendant Arm with Wiring	VG4-PEND-ARM
Mounting plate for VG4-PEND-ARM	VG4-PEND-WPLATE
Trim skirt for VG4 Series Power Supplies	VG4-A-TSKIRT

Optional Mounting Plates for Arm Mounts

Corner Mounting Plate	VG4-A-9542
Pole Mounting Plate	VG4-A-9541

Pendant Pipe Mounts

Pipe Mount Kit	VG4-A-9543
----------------	------------

Pendant Roof Mounts

Roof (Parapet) Mount (VG4-A-9543 Pipe Mount Kit required. Available separately.)	VGA-ROOF-MOUNT (with 1.5-inch NPT tapered male threads)
-------------------------------------------------------------------------------------	---------------------------------------------------------

Optional Mounting Plates for Roof Mounts

Flat Roof Adapter for Parapet Mount	LTC 9230/01
-------------------------------------	-------------

In-ceiling Support Kits

	VGA-IC-SP (Bracket for suspended or drop ceilings)
--	----------------------------------------------------

Dimensional Drawings

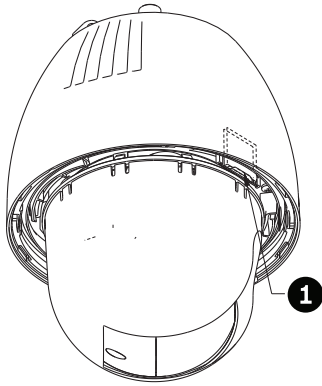

AUTODOME 7000 series - Slot for SD card

1 Slot for SD card

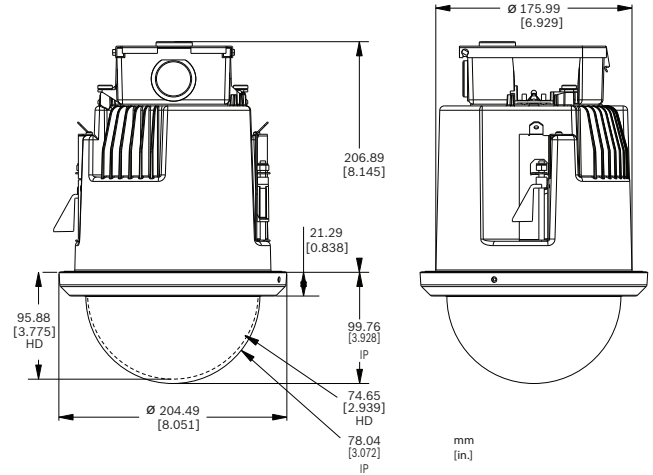

AUTODOME 7000 series In-ceiling

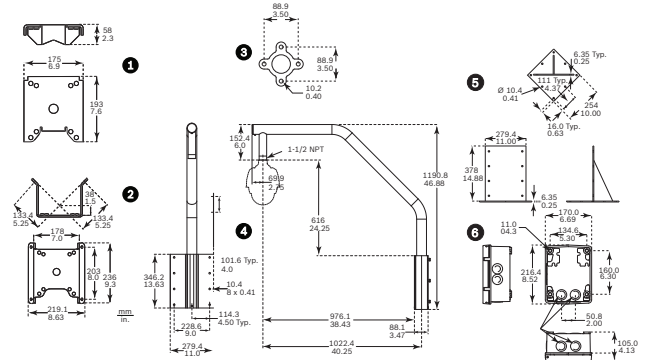
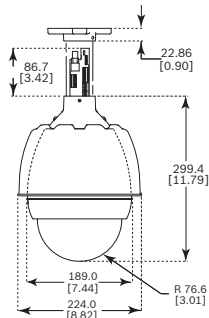

AUTODOME 7000 series Optional Mounts

- | | |
|---------------------|-----------------------------------------|
| 1 Pole (Mast) Mount | 4 Roof Mount |
| 2 Corner Mount | 5 Roof Mount Adapter |
| 3 Pipe Mount | 6 Power Supply for Pipe and Roof Mounts |

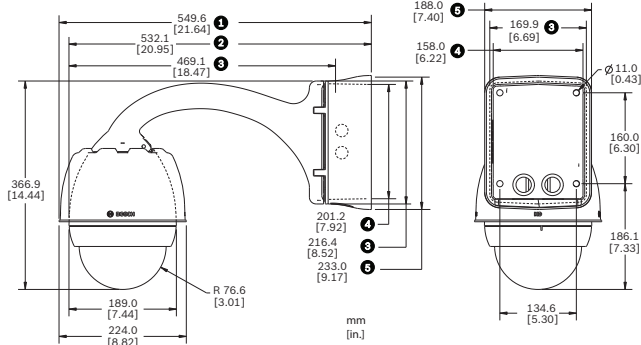

AUTODOME 7000 series Pipe, Pendant mounts

- | | |
|----------------------------------|--------------------|
| 1 Power supply box and sunshield | 4 Power supply box |
| 2 Sunshield removed | 5 Trim skirt |
| 3 Mounting plate | |

Ordering information

VG5-7230-EPC5 IP moving dome 1080p outdoor pendant

Superb quality indoor/outdoor IP PTZ dome camera. 1080p HD resolution; 30x optical zoom; IVA; PoE; iSCSI/SD; multiple pre-programmed user modes; H. 264 quad-streaming (CPP4); IP66. Pendant mount, clear bubble.

Order number **VG5-7230-EPC5**

VG5-7230-EPR5 Rugged IP moving dome 1080p outdoor pendant

Superb quality indoor/outdoor IP PTZ dome camera. 1080p HD resolution; 30x optical zoom; IVA; PoE; iSCSI/SD; multiple pre-programmed user modes; H. 264 quad-streaming (CPP4); IP66. Pendant mount, IK10-rated bubble. Available in specific regions only.

Order number **VG5-7230-EPR5**

VG5-7230-CPT5 IP moving dome 1080p indoor in-ceiling

Superb quality indoor IP PTZ dome camera. 1080p HD resolution; 30x optical zoom; IVA; PoE; iSCSI/SD; multiple pre-programmed user modes; H.264 quad-streaming (CPP4); IP54. In-ceiling mount, tinted bubble.

Order number **VG5-7230-CPT5**

Accessories**NPD-6001A High PoE midspan 60 W, single port, AC in**

High Power, 60 W Single Port PoE Midspan with AC in

Order number **NPD-6001A**

VG4-A-PSU0 24 VAC Power Supply Unit

Power supply, 24 VAC input, for a PTZ camera in the AUTODOME Series. White, aluminum enclosure with cover, rated IP66 and IK 08. 100 W output. Optional trim skirt (sold separately).

Order number **VG4-A-PSU0**

VG4-A-PSU1 120 VAC Power Supply Unit

Power supply with transformer, 120 VAC input, for an AUTODOME or MIC7000 Series PTZ camera. White, aluminum enclosure with cover, rated IP66 and IK 08. 100 W output. Optional trim skirt (sold separately).

Order number **VG4-A-PSU1**

VG4-A-PSU2 230 VAC Power Supply Unit

Power supply with transformer, 230 VAC input, for an AUTODOME or MIC7000 Series PTZ camera. White, aluminum enclosure with cover, rated IP66 and IK 08. 100 W output. Optional trim skirt (sold separately).

Order number **VG4-A-PSU2**

VG4-SFPCKT Fiber Optic Ethernet Media Converter Kit

Ethernet media converter video transmitter/data receiver fiber optic kit for AUTODOME cameras and for MIC-IP-PSU for MIC analog cameras.

Order number **VG4-SFPCKT**

SFP-2 Small Form-factor Pluggable Optical Interface

SFP Fiber Optic Module, Multi-mode, 1310 nm, 2 km (1.2 miles), 2 LC connectors

Order number **SFP-2**

SFP-3 Small Form-factor Pluggable Optical Interface

SFP Fiber Optic Module, Single-mode, 1310 nm, 20 km (12.4 miles), 2 LC connectors

Order number **SFP-3**

SFP-25 Small Form-factor Pluggable Optical Interface

SFP Fiber Optic Module, Multi-mode, 1310/1550 nm, 2 km (1.2 miles), 1 SC connector

Order number **SFP-25**

SFP-26 Small Form-factor Pluggable Optical Interface

SFP Fiber Optic Module, Multi-mode, 1550/1310 nm, 2 km (1.2 miles), 1 SC connector

Order number **SFP-26**

VG4-A-PA0 Pendant Arm Mount

Pendant arm mount with power supply box for an AUTODOME Series camera, no transformer, white

Order number **VG4-A-PA0**

VG4-A-PA1 Pendant Arm Mount with 120 VAC Transformer

Pendant arm mount with power supply box for an AUTODOME Series camera with a 120 VAC transformer, white

Order number **VG4-A-PA1**

VG4-A-PA2 Pendant Arm Mount with 230 VAC Transformer

Pendant arm mount with power supply box for an AUTODOME Series camera with a 230 VAC transformer, white

Order number **VG4-A-PA2**

VGA-PEND-ARM Pendant Arm with Wiring

Compatible with an AutoDome Series pendant housing

Order number **VGA-PEND-ARM**

VGA-PEND-WPLATE Mounting Plate

Mounting plate for VGA-PEND-ARM, compatible with an AutoDome Series camera

Order number **VGA-PEND-WPLATE**

VGA-ROOF-MOUNT Roof Mount

Roof parapet mount, white

VG5-6xx/7xxx cameras require VG4-A-9543 Pipe Mount (sold separately).

NEZ-5130-/NEZ-5230- cameras require NDA-ADPTR-NPTMET (sold separately)

Order number **VGA-ROOF-MOUNT**

LTC 9230/01 Flat Roof Mount Adapter

For mounting a unit in an upright position on a flat surface for roof parapet mount VGA-ROOF-MOUNT

Order number **LTC 9230/01**

VG4-A-9541 Pole Mount Adapter

Pole mount adapter for an AUTODOME pendant arm or a DINION imager, designed for poles with a diameter of 100-380 mm (4-15 in.), white

Order number **VG4-A-9541**

VG4-A-9542 Corner Mount Adapter

Corner mount adapter for an AUTODOME pendant arm or a DINION imager

Order number **VG4-A-9542**

VG4-A-9543 Pipe Mount

Pipe mount, white, for an AutoDome Series pendant housing

Order number **VG4-A-9543**

VGA-IC-SP In-ceiling Support Kit

Suspended ceiling support kit for dome cameras. Aperture Ø177 mm (Ø7 in). Maximum supported weight 11.3 kg (25 lb).

Order number **VGA-IC-SP**

VGA-SBOX-COVER Cover for AUTODOME Power Supply Boxes

Cover for AUTODOME Power Supply Boxes, white
Order number **VGA-SBOX-COVER**

VG4-A-TSKIRT Trim Skirt for AUTODOME Power Supply Boxes

Trim skirt for the following AutoDome Series power supply boxes:
VG4-A-PSU0, VG4-A-PSU1, and VG4-A-PSU2
Order number **VG4-A-TSKIRT**

VGA-BUBBLE-PCLA Clear High-resolution Bubble for a Pendant Housing

Low-impact acrylic bubble
Order number **VGA-BUBBLE-PCLA**

VGA-BUBBLE-PTIA Tinted High-resolution Bubble for a Pendant Housing

Low-impact acrylic bubble
Order number **VGA-BUBBLE-PTIA**

VGA-BUBLRG-CCLA AD Large InCeil Can HighRes Bubble Clear

High-resolution bubble for AUTODOME in-ceiling cameras, clear
Order number **VGA-BUBLRG-CCLA**

VGA-BUBLRG-CTIA AD Large InCeil Can HighRes Bubble Tint

High-resolution bubble for AUTODOME in-ceiling cameras, tinted
Order number **VGA-BUBLRG-CTIA**

VGA-BUBHD-CTIA Tinted HD High-Resolution Acrylic Bubble for In-Ceiling AUTODOME cameras

High-resolution acrylic bubble for AUTODOME HD in-ceiling cameras, tinted
Order number **VGA-BUBHD-CTIA**

VGA-BUBBLE-IK10 IK10 Bubble for pendant housing

IK10-rated bubble qualified for use with AUTODOME 7000 HD cameras with pendant housings
Order number **VGA-BUBBLE-IK10**

Represented by:

Europe, Middle East, Africa:
Bosch Security Systems B.V.
P.O. Box 80002
5600 JB Eindhoven, The Netherlands
Phone: + 31 40 2577 284
emea.securitysystems@bosch.com
emea.boschsecurity.com

Germany:
Bosch Sicherheitssysteme GmbH
Robert-Bosch-Ring 5
85630 Grasbrunn
Germany
www.boschsecurity.com

North America:
Bosch Security Systems, Inc.
130 Perinton Parkway
Fairport, New York, 14450, USA
Phone: +1 800 289 0096
Fax: +1 585 223 9180
onlinehelp@us.bosch.com
www.boschsecurity.us

Asia-Pacific:
Robert Bosch (SEA) Pte Ltd, Security Systems
11 Bishan Street 21
Singapore 573943
Phone: +65 6571 2808
Fax: +65 6571 2699
apr.securitysystems@bosch.com
www.boschsecurity.asia