

PFA100

Mount Adapter



Features

- Material: Aluminum
- Mount Adapter
- Neat & Integrated design

Specifications

| | |
|-----------------------|----------------------------------|
| Model | PFA100 |
| General | |
| Material | Aluminum |
| Dimension (W x H x D) | φ150.8mm x 37mm |
| Pipe Thread | G1 1/2" |
| Operating Temperature | -40°C ~60°C |
| Humidity | 0~90% RH |
| Load Bearing | 3.0Kg |
| Weight | 0.21Kg |
| Applicable Model | Please see "Accessory Selection" |

PFA100

Dimensions (mm)

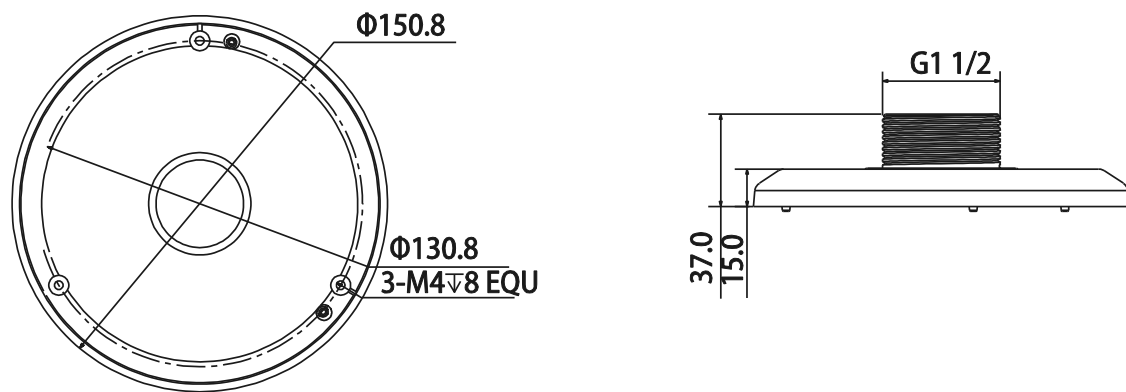

Application

