

EH1000 Enclosure

INDOOR, IN-CEILING, FOR SINGLE CAMERA

Product Features

- Low Profile, Large "Wedge" Style
- Tamper Resistant
- Designed for Use with Large Format Cameras
- Can Be Installed in Fixed or Dropped (False) Ceilings
- Hinged Door Opens for Convenient Access to Camera



EH1000 MOUNTED IN DROPPED CEILING
USING E1003 MOUNTING PLATE

The **EH1000** is a low profile ceiling enclosure for use with large format cameras. The unobtrusive, streamlined design compliments any business or office decor.

The **EH1000** is designed for use in fixed or dropped (false) ceiling and has a riveted back box constructed of aluminum.

An optional rotating mounting plate (**E1003**) is available for dropped ceiling applications. The **E1003** is easily rotated in 10-degree increments and features a locking capability to secure enclosure positioning.

The **EH1000** is engineered for ease of installation and service. The lower section is hinged to provide convenient access for camera and lens adjustments. The upper section has generous interior dimensions, allowing for additional camera angle adjustments. The enclosure is equipped with a tamper-resistant lock for security protection. Cable entry is through conduit knockouts.

The **EH1000** and **E1003** are manufactured with a white textured finish to provide a more unobtrusive appearance.

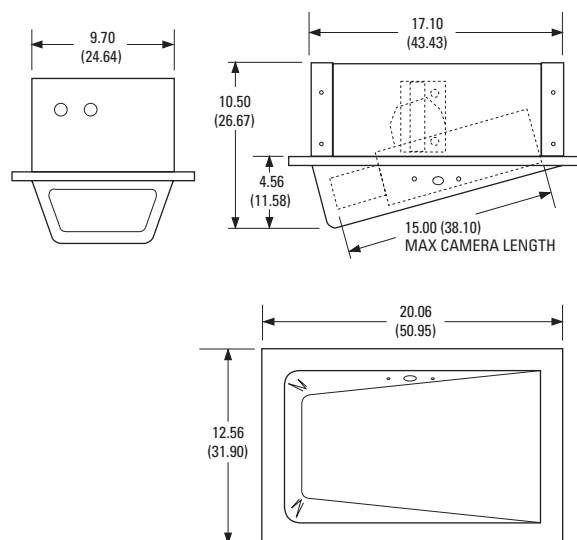

NOTE: VALUES IN PARENTHESES ARE CENTIMETERS;
ALL OTHERS ARE INCHES.



TECHNICAL SPECIFICATIONS

MODEL

EH1000 Low profile ceiling enclosure

MECHANICAL

Camera Mounting	Adjustable bracket capable of supporting a maximum of 10 lb (4.53 kg)
Maximum Camera and Lens Size	Accepts camera and lens combinations* (including BNC connector) up to: 4.50" H x 6.50" W x 15.00" L (11.43 x 16.51 x 38.10 cm)
Ceiling Mounting	Upper section flange-mounted to fixed ceiling or E1003 rotating mounting plate for false ceilings
Cable Entry	Conduit knockouts on upper back box; two on each end
Lock	Key lock

*Assumes lens is fully extended.

GENERAL

Construction	
Upper section	5052H32 aluminum
Lower section	Vacuum-formed ABS plastic
Viewing Window	Lucite® SAR (Super Abrasion Resistant) acrylic
Color	
Upper section	Alodine
Lower section	White textured
Environment	Indoor; 32° to 120°F (0° to 49°C)
Unit Weight	
EH1000	5.16 lb (2.34 kg)
E1003	3.1 lb (1.41 kg)
Shipping Weight	
EH1000	8 lb (3.6 kg)
E1003	5 lb (2.25 kg)

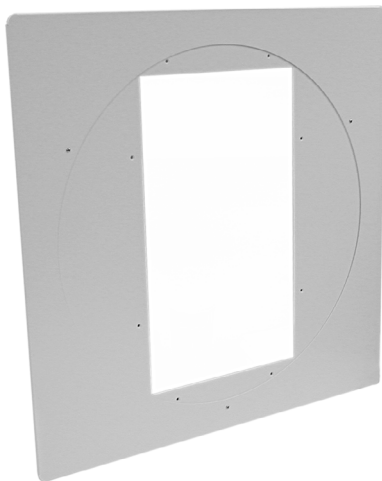

E1003 ROTATING MOUNTING PLATE

CERTIFICATIONS/RATINGS

- UL Listed
- Meets NEMA Type 1 standards

OPTIONAL ACCESSORIES

E1003	360° rotating mounting plate; rotates in 10° increments and features locking capability to secure enclosure positioning. Replaces 2 ft x 2 ft (61 cm x 61 cm) ceiling tile; can be used in 2 ft x 4 ft (61 cm x 122 cm) ceiling tile with additional T-rail for support. Constructed of aluminum with textured white polyester powder coat finish.
EH664004COMP	Replacement lock with two keys.

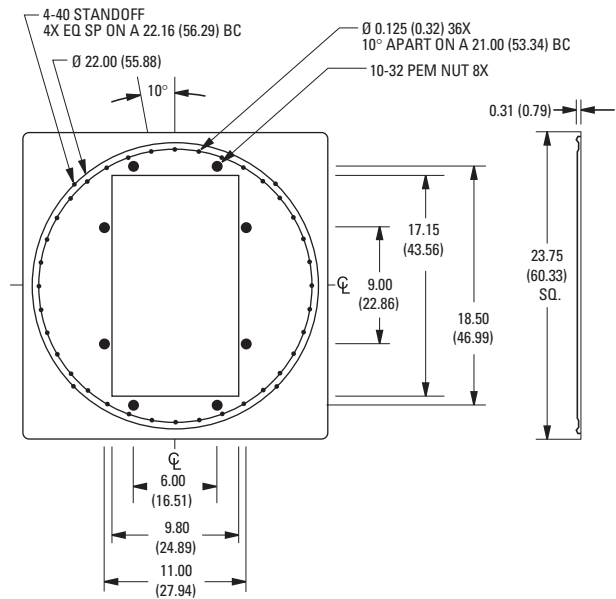

NOTE: VALUES IN PARENTHESES ARE CENTIMETERS; ALL OTHERS ARE INCHES.

E1003 DIMENSION DRAWING



Pelco, Inc. Worldwide Headquarters:
3500 Pelco Way, Clovis, California 93612-5699 USA
USA & Canada Tel: (800) 289-9100 • FAX: (800) 289-9150
International Tel: +1 (559) 292-1981 • FAX: +1 (559) 348-1120
www.pelco.com

Pelco and the Pelco logo are registered trademarks of Pelco, Inc.
Lucite is a registered trademark of DuPont.
Product specifications and availability subject to change without notice.
©Copyright 2002, Pelco, Inc. All rights reserved.