



# GV-Wiegand Capture

## *User's Manual*



The GeoVision logo and GV series products are trademarks of GeoVision, Inc.  
© 2006 GeoVision, Inc. All rights reserved.  
All GeoVision Products are manufactured in Taiwan.

2006/11  
English  
WCV10-A

Before attempting to connect or operate this product, please read these instructions carefully and save this manual for future use.

# Table of Contents

<b>1. Introduction</b>	<b>1</b>
1.1 Features	1
1.2 Packing List	1
1.3 System Requirements	1
<b>2. Overview</b>	<b>2</b>
2.1 Front Panel	2
2.2 Rear Panel	3
<b>3. Connections</b>	<b>4</b>
3.1 Connecting GV-System through RS-232	4
3.2 Connecting GV-System through RS-485	5
3.3 Connecting Multiple GV-Wiegand Capture Boxes	6
<b>4. DVR Configurations</b>	<b>7</b>
4.1 Device Setting	7
4.2 Code Format Setting	8
4.3 Database Connection Setting	9
4.4 Text Overlay Setting	14
<b>5. I/O Setting</b>	<b>16</b>
<b>6. Input Configurations</b>	<b>20</b>
<b>7. Specifications</b>	<b>21</b>



# 1. Introduction

Through the GV-Wiegand Capture, your access control system may integrate to the GV-System. The GV-Wiegand Capture serves as an interface between your current access control system and GV-System by intercepting Wiegand signal and interpreting it to both systems. It can turn your access control system into a powerful video surveillance access system.

## 1.1 Features

- Integrate Wiegand-interface access control systems to GV-System
- Overlay the cardholder's data and photo onto the surveillance video
- Support Wiegand output formats from 26 bits to 40 bits
- Support Microsoft ODBC database
- Support 2 digital inputs and relay outputs
- Through multiple GV-Wiegand Capture boxes, the maximum of 16 access control systems can link to one GV-System

## 1.2 Packing List

- GV-Wiegand Capture Box x 1
- Power Adaptor DC 12V x 1
- DB9 RS-232 Cable (1.8 meters / 6 feet) x 1
- Wall Hook x 1

## 1.3 System Requirements

Version 8.1 or later

## 2. Overview

This chapter identifies the various components of the GV-Wiegand Capture.

### 2.1 Front Panel

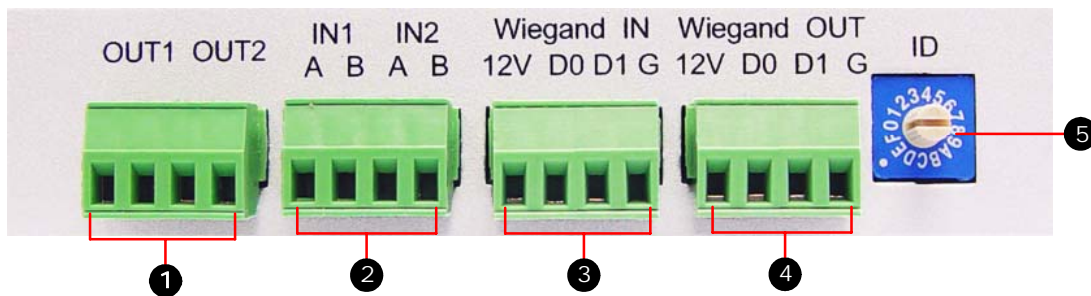

Figure 2-1

No.	Name	Function
1	Output Terminal Block	Support 2 relay outputs.
2	Input Terminal Block	Support 2 digital inputs.
3	Wiegand In Terminal Block	Input Wiegand signal.
4	Wiegand Out Terminal Block	Output Wiegand signal.
5	ID Switch	Up to 16 GV-Wiegand Capture Boxes can connect to one GV-System. 16 IDs from 0 ~ 9 and A ~ F are available for setup.

## 2.2 Rear Panel

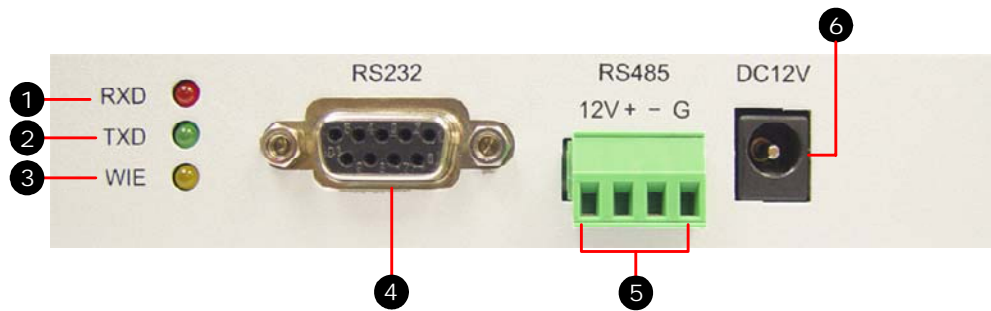

Figure 2-2

No.	Name	Function
1	Receive Data LED	This LED is on, indicating that data is received by the GV-System.
2	Transmit Data LED	This LED is on, indicating the data is transmitted to the GV-System.
3	Wiegand LED	This LED is on, indicating the Wiegand data is transmitted.
4	RS-232 Connector	Connect to the GV-System.
5	RS-485 Terminal Block	Connect to the GV-System.
6	DC IN 12V Power	A plug for power input.

### 3. Connections

This chapter includes four diagrams of connecting the access control system to the GV-System through the GV-Wiegand Capture.

#### 3.1 Connecting GV-System through RS-232

When the physical distance between the GV-Wiegand Capture and the GV-System is less than 10 meters (32 ft), use the supplied RS-232 cable for connection.

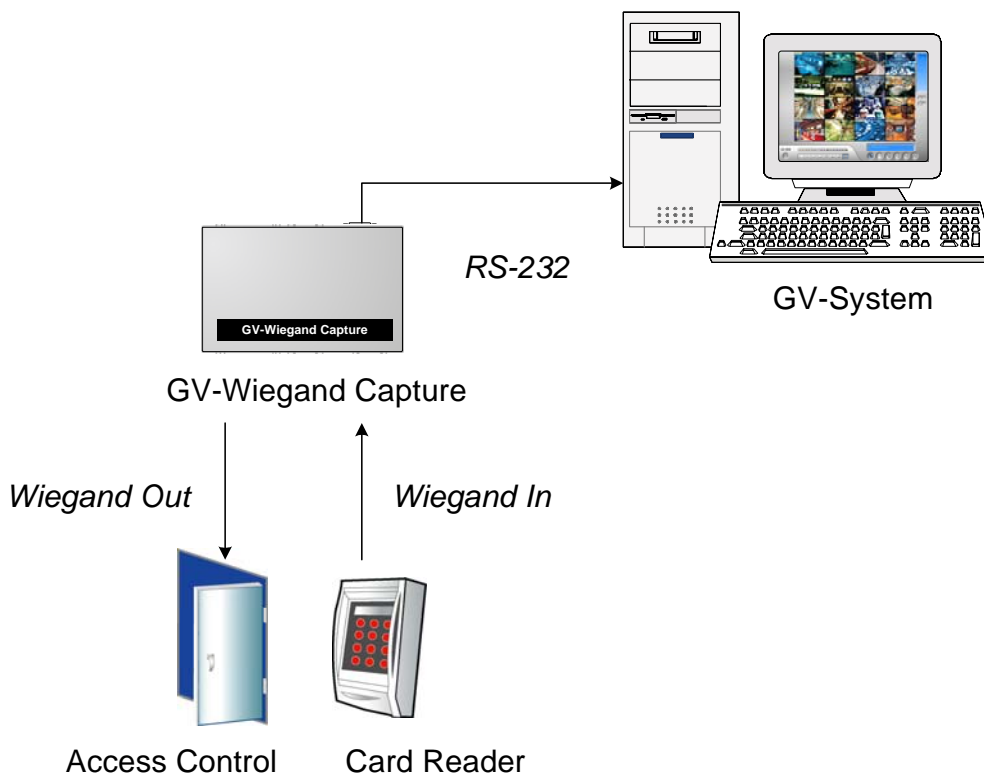

Figure 3-1

### 3.2 Connecting GV-System through RS-485

When the physical distance between the GV-Wiegand Capture and the GV-System is greater than 10 meters (32 ft), it is required to use (1) GV-NET series or (2) GV-Hub / GV-COM in the RS-485 connection.

---

**Note:** The maximum distance of RS-485 is 600 meters (2000 ft).

---

#### Using GV-NET series in the connection:

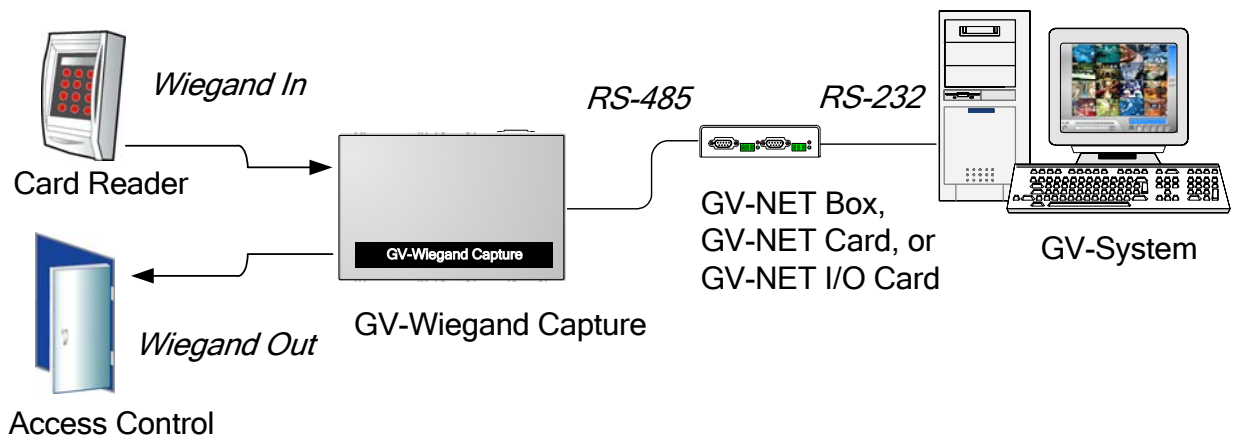

Figure 3-2

#### Using GV-Hub / GV-COM in the connection:

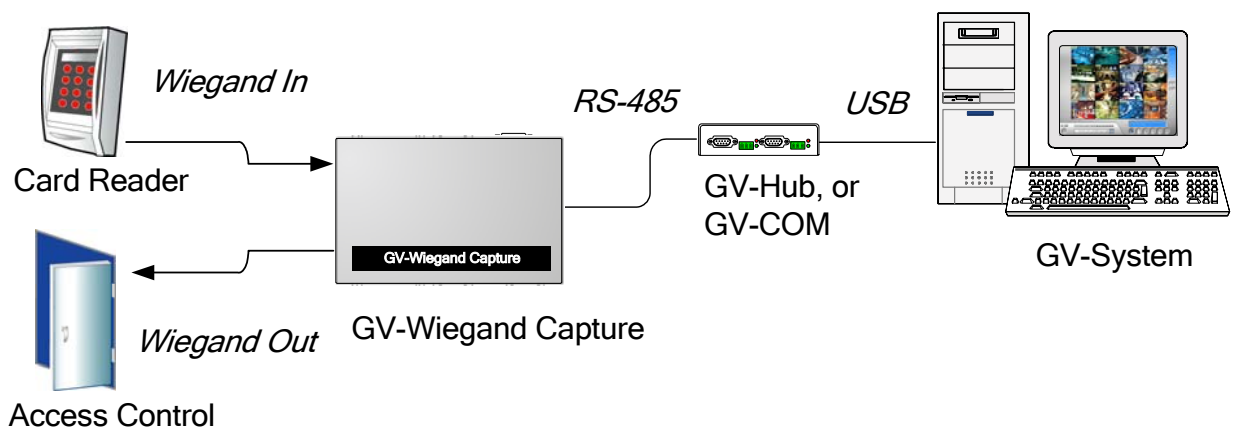

Figure 3-3



### 3.3 Connecting Multiple GV-Wiegand Capture Boxes

Through multiple GV-Wiegand Capture Boxes, you can connect up to 16 access control systems to a single GV-System.

For the connection of multiple GV-Wiegand Capture Boxes, there are distance limits and requirements for RS-485 communication:

1. If the physical distance between the GV-Wiegand Capture and GV-System is **within 100 meters (328 ft)**, use the general RS-485 cable.
2. If the physical distance between the GV-Wiegand Capture and GV-System is **within 100-300 meters (328 ~ 984 ft)**, we recommend using the RS-485 cable with characteristic impedance of 1KHz 120 ohms, defined by EIA-485 specifications.

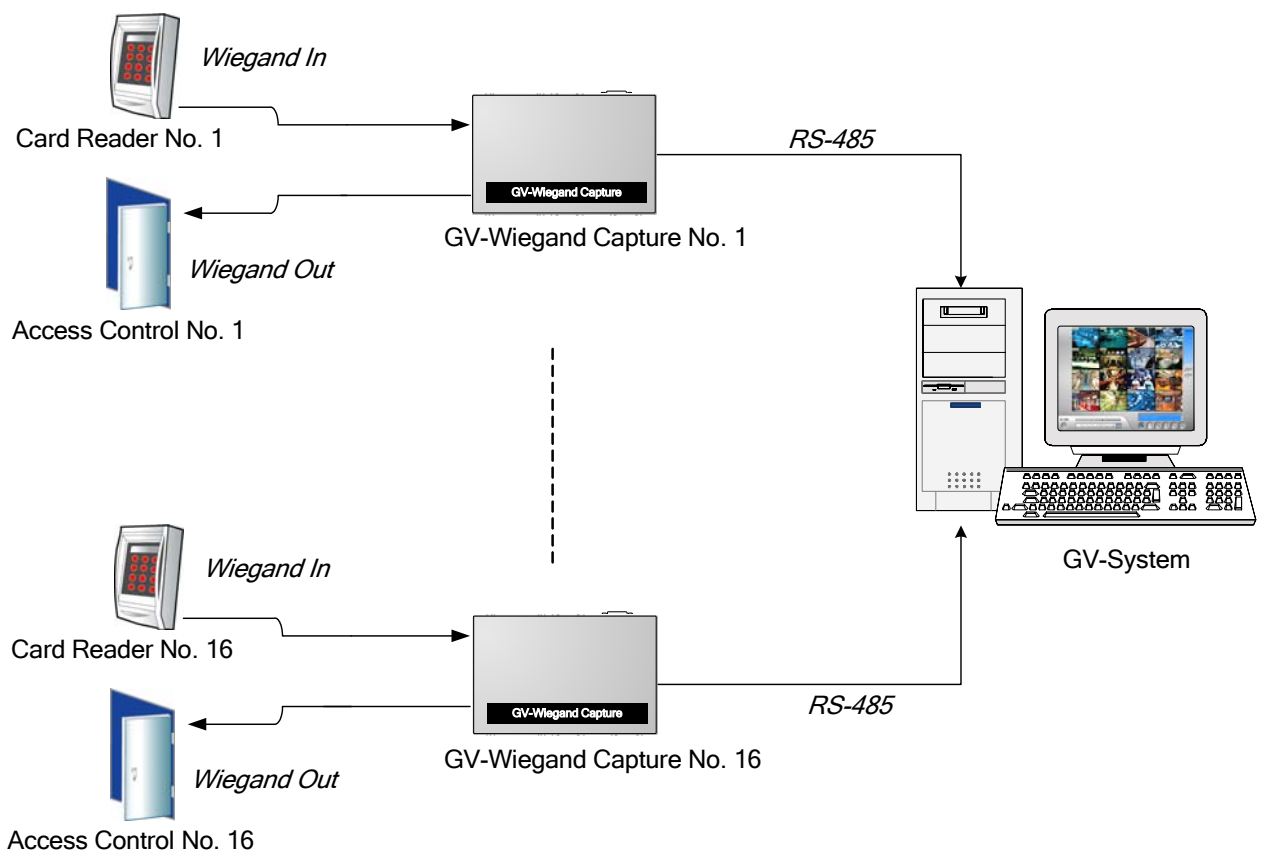

Figure 3-4

## 4. DVR Configurations

After connections, you must configure the GV-System before it can overlay access data on the surveillance video.

### 4.1 Device Setting

To add the access control system to the GV-System, follow these steps:

1. Click the **Configure** button, and select **GV Wiegand Capture Device Setting**. This dialog box appears.

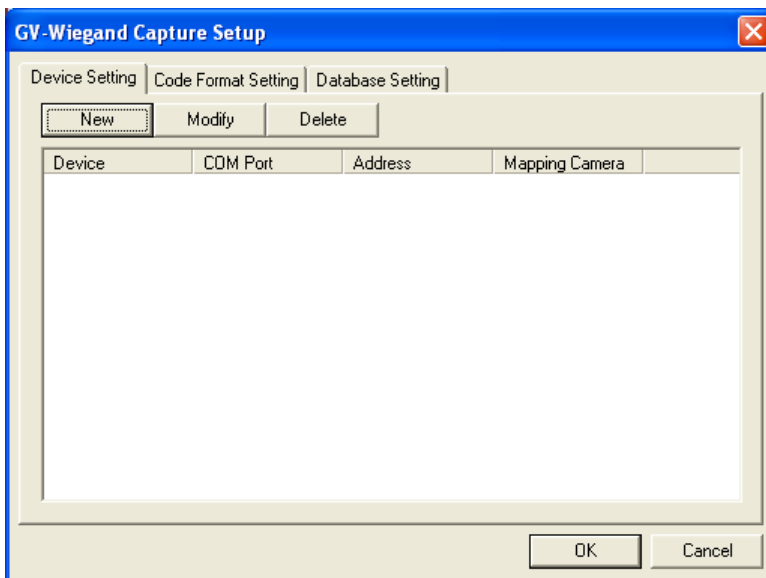

Figure 4-1

2. Click the **New** button. This dialog box appears.

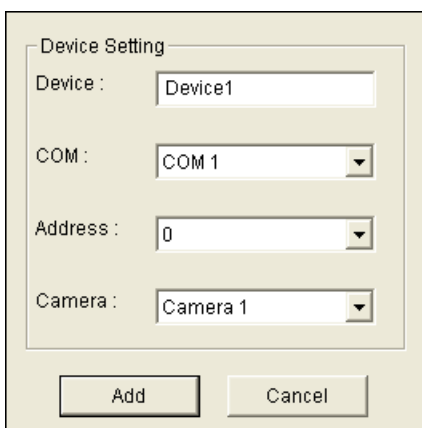

Figure 4-2

- **Device:** Give a name to the access control system.
  - **COM:** Select the COM port connected to the GV-Wiegand Capture.
  - **Address:** Select the ID of the connected GV-Wiegand Capture from 0 to 9 and A to F. The address should match the ID setting on the front panel of the GV-Wiegand Capture.
  - **Camera:** Assign the access control system to a channel on which access data would overlay.
3. After above settings, click **Add** to add the access control system to the GV-System.

## 4.2 Code Format Setting

The default code format is set to 26-bit and 37-bit Wiegand formats. If your access control system is not either of the two formats, click the **Code Format** drop-down list, select **Customized**, and click the **Add** button to define your Wiegand format.

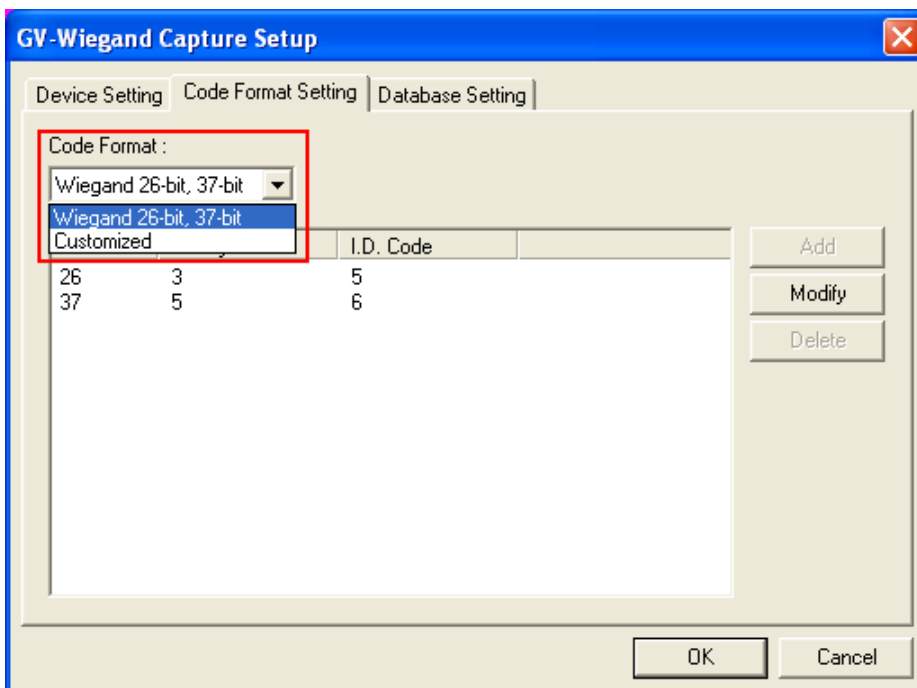

Figure 4-3

### 4.3 Database Connection Setting

The GV-Wiegand Capture provides you with a GV-Wiegand Capture Database to manage and store data. In addition, it supports the connection to a third-party database through the Microsoft Open Database Connectivity (ODBC) interface.

#### Setting up GV-Wiegand Capture Database

To set up the database, check the **Use GV-Wiegand Capture Database** option, and then click the **Database Setup** button to have these options.

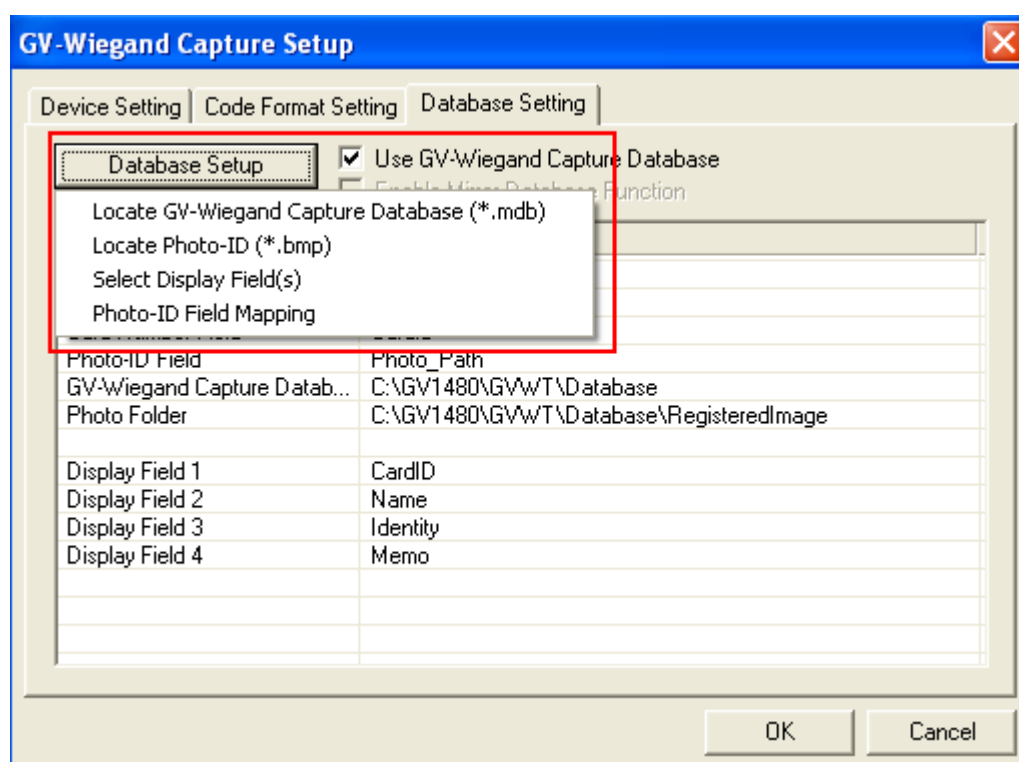

Figure 4-4

- **Locate GV-WT Database:** Assign the database path.
- **Locate Photo-ID:** Assign the photo path. Please note the maximum of image size should be 100 x 100 pixels in BMP format.
- **Select Display Field(s):** Specify the display fields on the screen, such as Card ID, Identity, Name and Memo (see *Figure 4-9*).
- **Photo-ID Field Mapping:** Select the photo-ID field so that the database can map the photo's ID to its corresponding photo (see *Figure 4-8*).

## Creating a Microsoft ODBC Connection:

The GV-Wiegand Capture supports the connection to a third-party database, such as Microsoft Access and a spreadsheet, through the Microsoft ODBC interface, providing you another option to access information. To create an ODBC connection, follow these steps:

1. In the Database Setting tab, uncheck **Use GV-Wiegand Capture Database**. This dialog box appears.

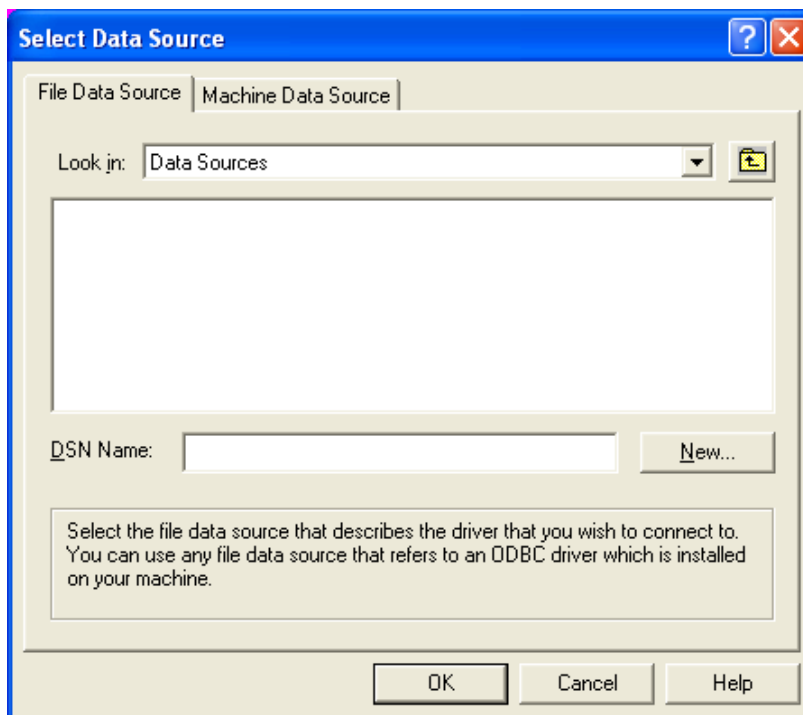

Figure 4-5

2. If the data source connection information is already installed on the computer, click the **Machine Data Source** tab to select the desired file.

If not, click the **File Data Source** tab, use the drop-down list to locate the DSN file, or click **New** to create a new file data source, and then click **OK**. This dialog box appears.

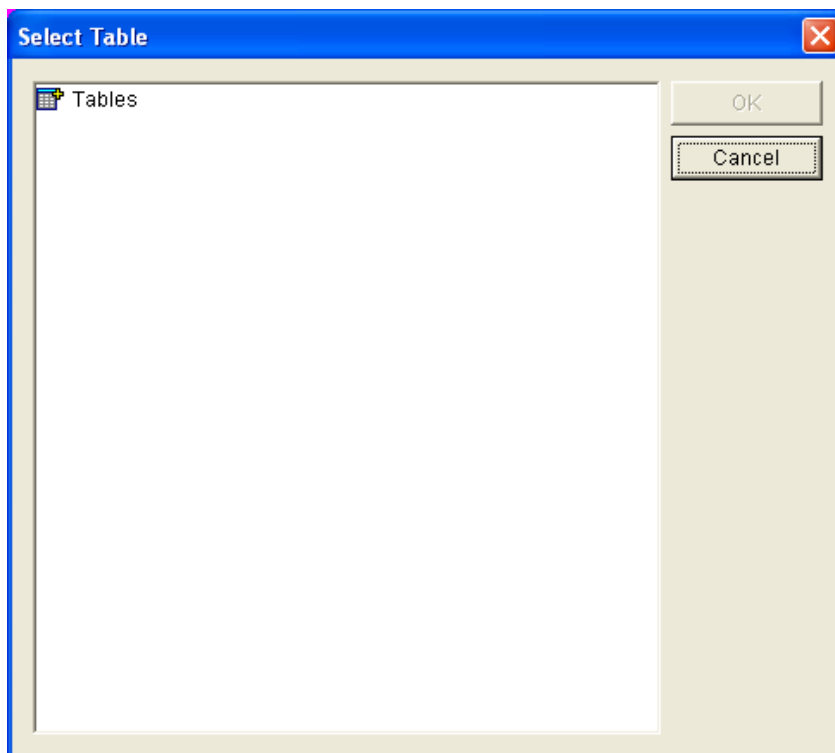

Figure 4-6

3. Expand **Tables** and then select the desired table. This dialog box appears.

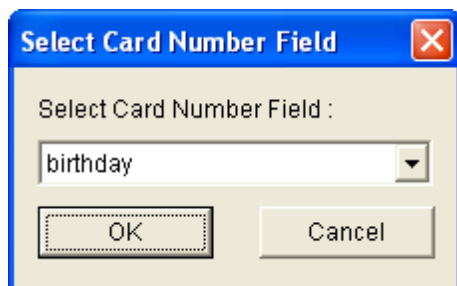

Figure 4-7

4. The selections correspond to the categories set in the DSN file. Use the drop-down list to select the Card Number field, and click **OK**. This dialog box appears.



Figure 4-8

5. If you want to display the Photo-ID field, uncheck **No Photo-ID Field**, and click **OK**. This dialog box appears.

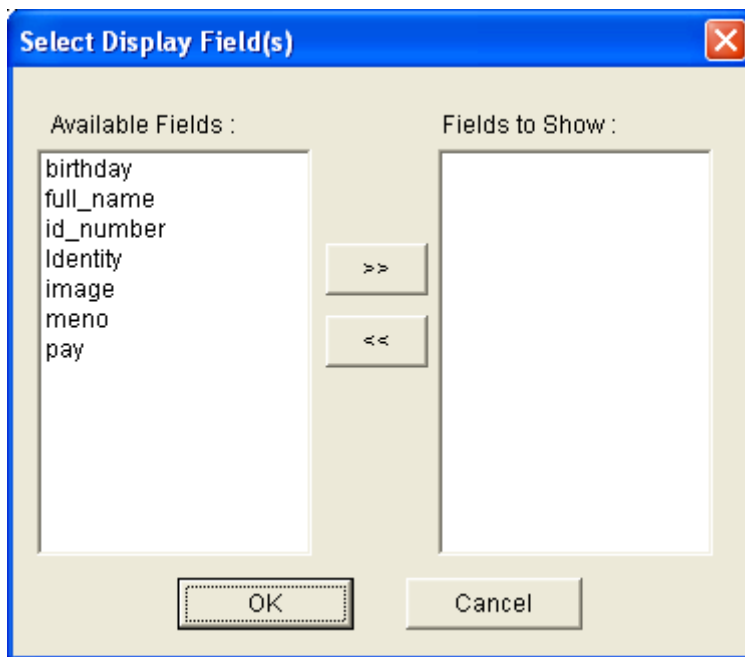

Figure 4-9

6. Select the fields to be displayed, click the **Right-Arrow** button and then click **OK**. A warning message appears.

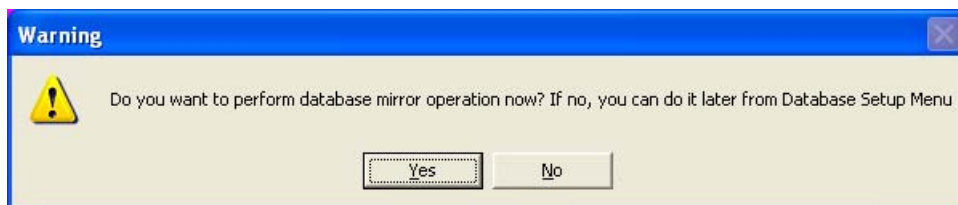

Figure 4-10

7. Click **Yes** to set up the backup file. **Enable Mirror Database Function** is then enabled.
8. In the Database Setting tab, click the **Database Setup** button (see *Figure 4-4*) to have these options.

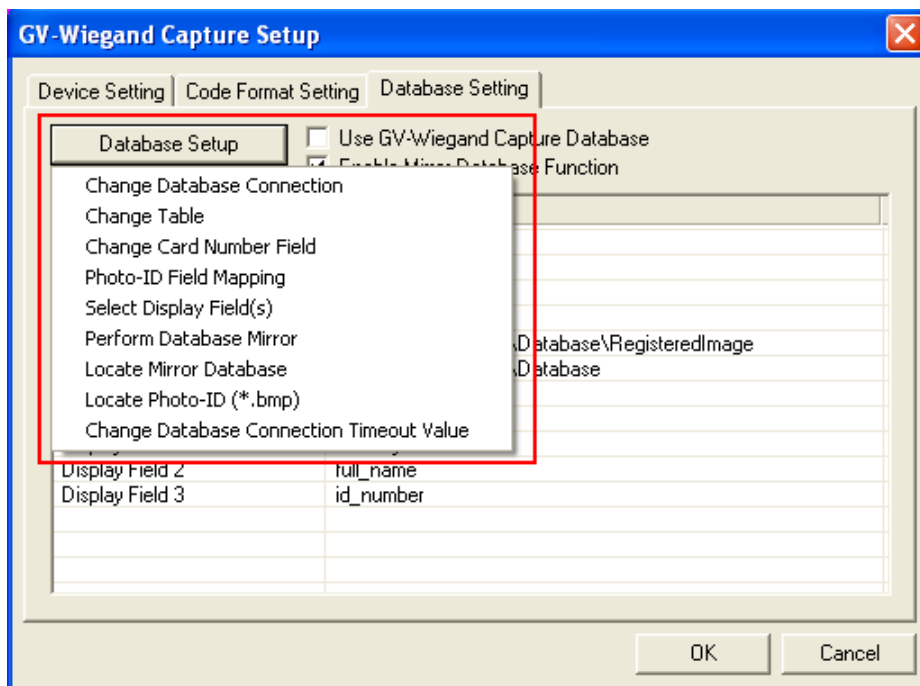

Figure 4-11

- **Change Database Connection:** Change the data source (see Figure 4-5).
- **Change Table:** Select another table to retrieve information (see Figure 4-6).
- **Change Card Number Field:** Change the previous setting of the Card Number field (see Figure 4-7).
- **Photo-ID Field Mapping:** Select the photo-ID field so that the database can map the photo's ID to its corresponding photo (see Figure 4-8).
- **Select Display Field(s):** Specify the display fields on the screen, such as Card ID, Identity, Name and Memo (see Figure 4-9).
- **Perform Database Mirror:** Replicate the existing database.
- **Locate Mirror Database:** Assign the backup database file path.
- **Locate Photo-ID (\*.bmp):** Assign the photo path. Please note the maximum of image size should be 100 x 100 pixels in BMP format.
- **Change Database Connection Timeout Value:** The GV-Wiegand Capture supports the connection to the DSN file over the Internet. Use this option to set the time length for the database connection. The maximum time length is 15 seconds.



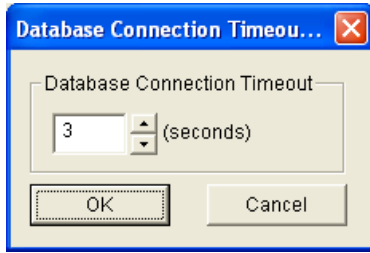

Figure 4-12

## 4.4 Text Overlay Setting

You can overlay and position the access data, such as Card ID, Identity, Name, Memo and photo, onto the surveillance video. To access this feature, click the **Configure** button and select **Text Overlay Setting**.

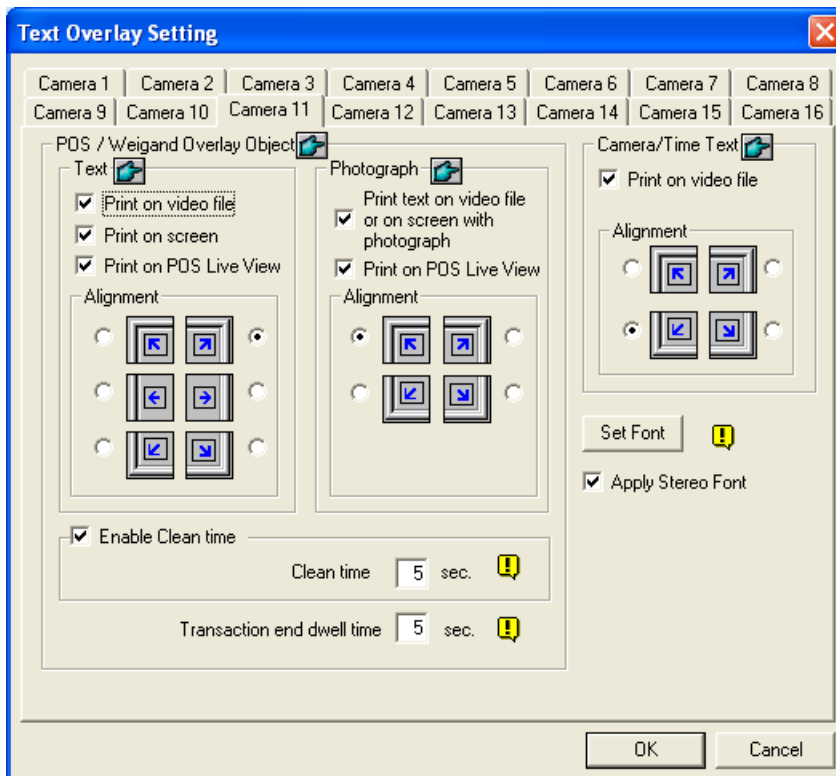

Figure 4-13

### [ POS / Wiegand Overlay Object ]

- **Print on video file:** Overlays the cardholder's data onto the recorded file.
- **Print on screen:** Overlays the cardholder's data onto the live video.
- **Print on POS Live View:** Displays the cardholder's data on the separate POS Live View window (see Figure 4-14).

- **Alignment:** Sets the position of text overlay on the screen.

[ Photograph ]

- **Print text on video file or on screen with photograph:** Overlays the photo with access data onto the live video or the recorded file.
- **Print on POS Live View:** Displays the photo on the separate POS Live View window (See Figure 4-14).
- **Alignment:** Sets the position of photo overlay on the screen.

[ Camera/Time Text ]

- **Print on video file:** Overlays the camera ID, location name, date and time onto the recorded file.
- **Alignment:** Sets the position of Camera/Time text overlay on the screen.

[ Set Font ] Sets the font for text overlay. The option **Apply Stereo Font** makes text stand out from the background by giving white-edge to the text.

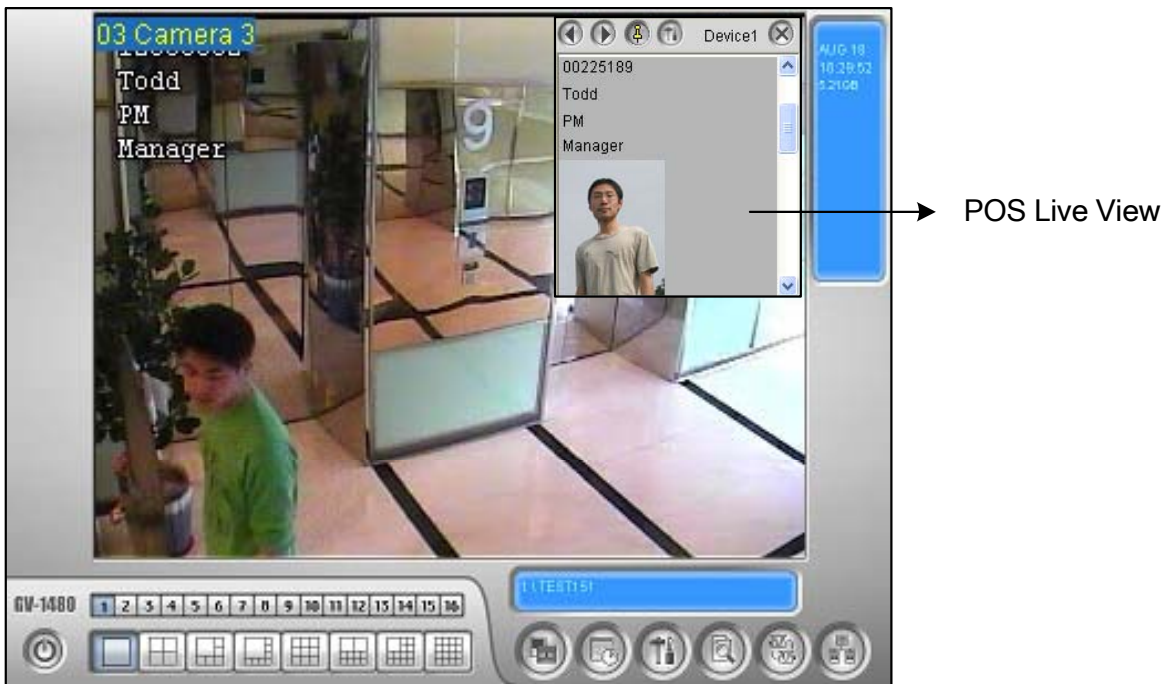

Figure 4-14 Overlaying access data on the POS Live View window

## 5. I/O Setting

One GV-Wiegand Capture supports two I/O devices. After setting up a GV-Wiegand Capture, you can configure and control the I/O devices connected to the GV-Wiegand Capture.

1. Click the **Configure** button, point to **I/O Application**, and select **Virtual I/O Setting**. This dialog box appears.

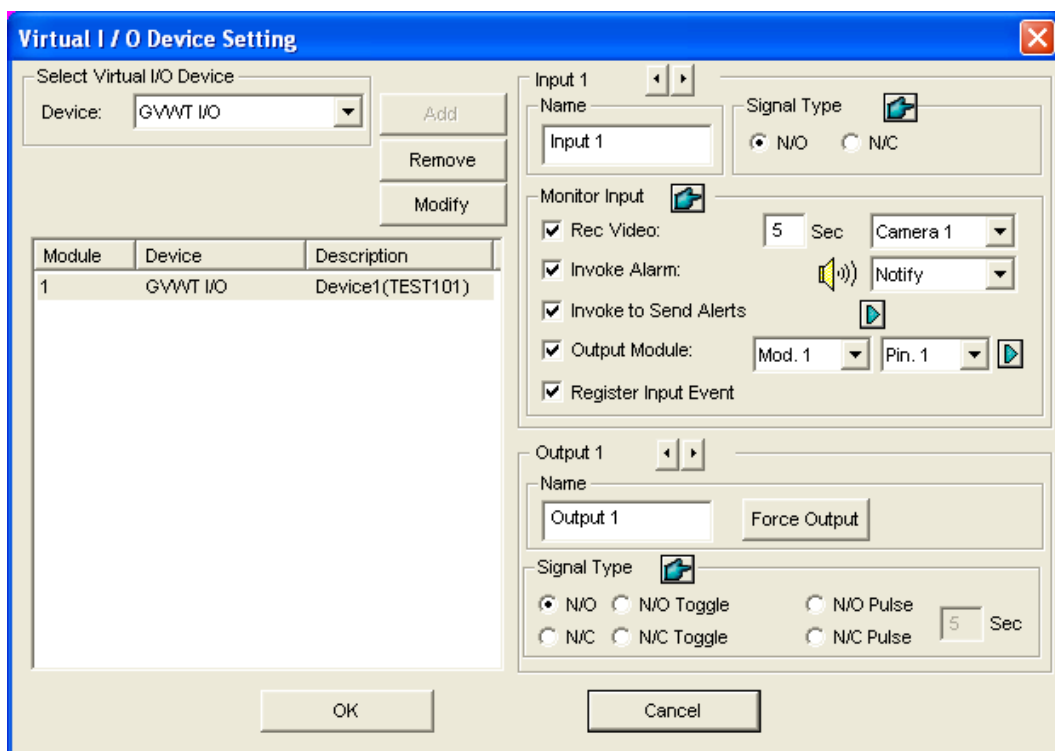

Figure 5-1

- In the Select Virtual I/O Device field, use the drop-down list to select **GVWT I/O**, and then click the **Add** button. This dialog box appears.

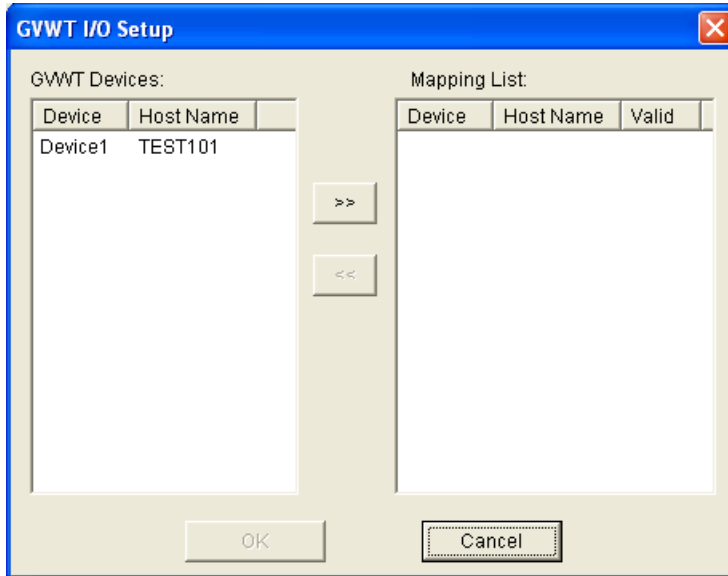

Figure 5-2

- Select the GV-Wiegand Capture, and click the right-arrow button to add this device to the Mapping List.
- Click **OK** to save the settings and return to the Virtual I/O Device Setting dialog box (See Figure 5-1).

[ **Input X** ] One GV-Wiegand Capture supports 2 inputs. Click the **Arrow** buttons to select an Input.

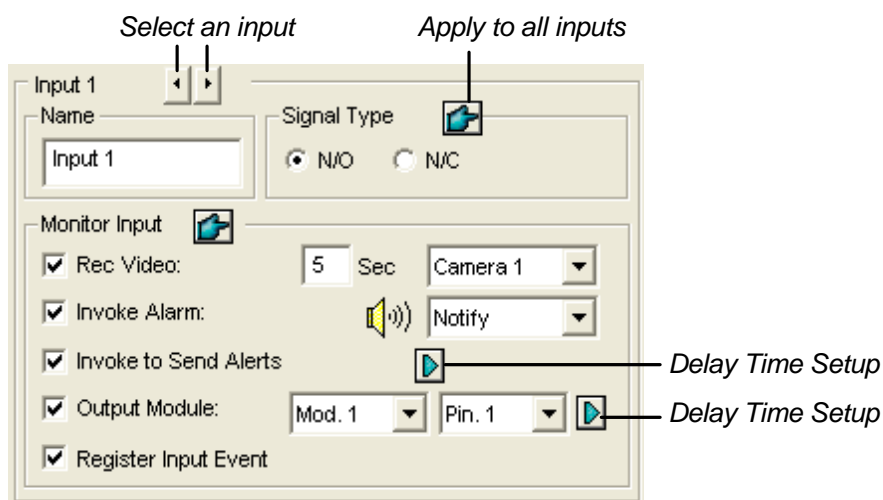

Figure 5-3

- **Name:** Name the selected input device in the Name field.

- **Signal Type:** Select **N/O** or **N/C** for your input device. You may use the **Finger** button to apply your selection to all input devices.

#### [ Monitor Input ]

- **Rec Video:** Check this option to use the input (sensors or detectors) to trigger recording. You may select which camera to record in the Camera Select drop-down list and specify the recording duration.
- **Invoke Alarm:** Check this option to activate computer alarm when the input is triggered. You may select the alarm type in the drop-down menu.
- **Invoke to Send Alerts:** Check this option to send out an assigned alert (E-Mail/Hotline/SMS) when the input is triggered.

**Right-Arrow button:** Click to set the delay time to activate assigned alerts (E-Mail/Hotline/SMS).

- **Output Module:** If the input is invoked, the system will automatically send a signal to an output pin.

**Right-Arrow button:** Click to set the delay time to activate the assigned output module.

---

**Note:** The delay functions in **Invoke to Send Alerts** and **Output Module** allow you time to deactivate prior alert and output settings. To deactivate these settings, you may stop monitoring or enable the assigned input module set at “**Deactivate notification when selected pin ON**” in I/O Application Setting.

---

- **Register Input Event:** This option logs the alarm events into System Log. Each event is labeled with ID, time, device name (camera or I/O input), corresponding module of the device, and event for later retrieval. For details on *System Log*, see Chapter 1, *User’s Manual* on the Surveillance System Software CD.

[ **Output X** ] One GV-Wiegand Capture supports 2 outputs. Click the **Arrow** buttons to select an Output.

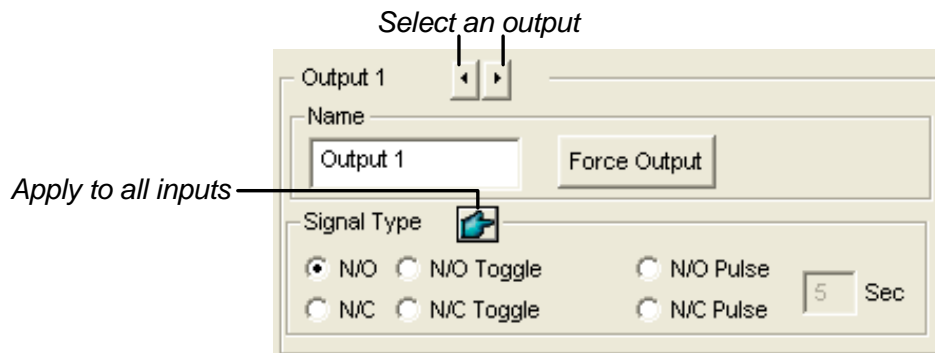

Figure 5-4

- **Name:** Name the selected output device in the Name field.
- **Force Output:** Click to test signal to the selected device.
- **Signal Type:** There are six signal types available: N/O (Normal Open), N/O Toggle, N/O Pulse, N/C (Normal Closed), N/C Toggle, and N/C Pulse. Choose the one that mostly suits the device you're using. The N/O Toggle or N/C Toggle signal type is the output high mode that turns to output low until the monitoring is stopped. You can also specify the pulse duration for pulse type signals.

---

**Note:** PTZ camera and I/O devices cannot be assigned to the same port at the same time.

---

## 6. Input Configurations

The GV-Wiegand Capture accepts input devices of dry contact or wet contact. Input 1 and 2 are set to be dry contact by default. To change the inputs to wet contact, open the casing and push the white switch downward.

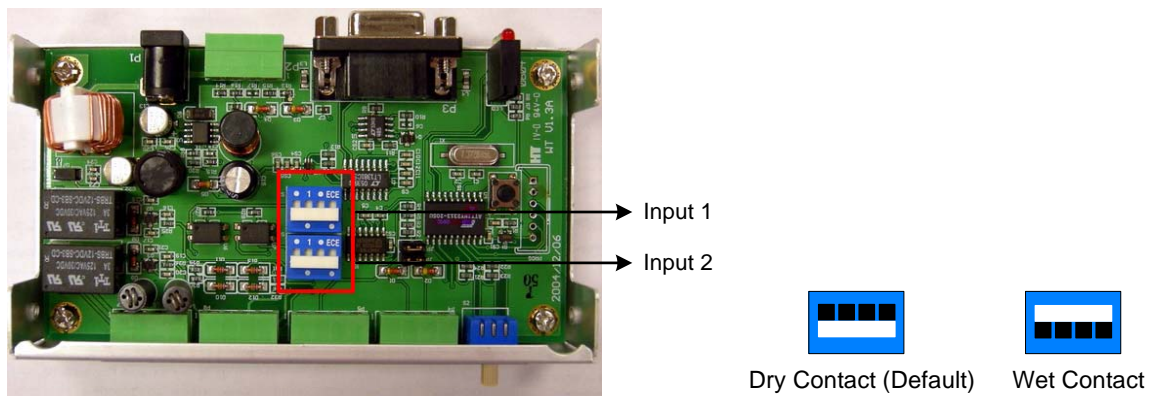

Figure 6-1

## 7. Specifications

Communication	RS-232	DB9 Female
	RS-485	Terminal Block
Input	Input	2
	Input Signal	12V Voltage input / dry-connect input
	High State	9~12V / close
	Low State	0V / open
Output	Relay Output	2
	Relay Status	Normal Open
	Relay Capacitance	3A / VAC125V, 1.5A / VAC250V
	Relay ON Time	4ms
	Relay OFF Time	4ms
Wiegand	Input Connector	12V, D0, D1, GND
	Output Connector	12V, D0, D1, GND
	Format	Wiegand 26 Bits~40 Bits
DC IN		DC 12V, 1A
Environmental Condition		0~55°C (32~104°F), 5%~95% (non-condensing)
Dimension		120mm (W) x 68mm (H) x 26mm (D)



# 1. Introduction

Through the GV-Wiegand Capture, your access control system may integrate to the GV-System. The GV-Wiegand Capture serves as an interface between your current access control system and GV-System by intercepting Wiegand signal and interpreting it to both systems. It can turn your access control system into a powerful video surveillance access system.

## 1.1 Features

- Integrate Wiegand-interface access control systems to GV-System
- Overlay the cardholder's data and photo onto the surveillance video
- Support Wiegand output formats from 26 bits to 40 bits
- Support Microsoft ODBC database
- Support 2 digital inputs and relay outputs
- Through multiple GV-Wiegand Capture boxes, the maximum of 16 access control systems can link to one GV-System

## 1.2 Packing List

- GV-Wiegand Capture Box x 1
- Power Adaptor DC 12V x 1
- DB9 RS-232 Cable (1.8 meters / 6 feet) x 1
- Wall Hook x 1

## 1.3 System Requirements

Version 8.1 or later

## 2. Overview

This chapter identifies the various components of the GV-Wiegand Capture.

### 2.1 Front Panel

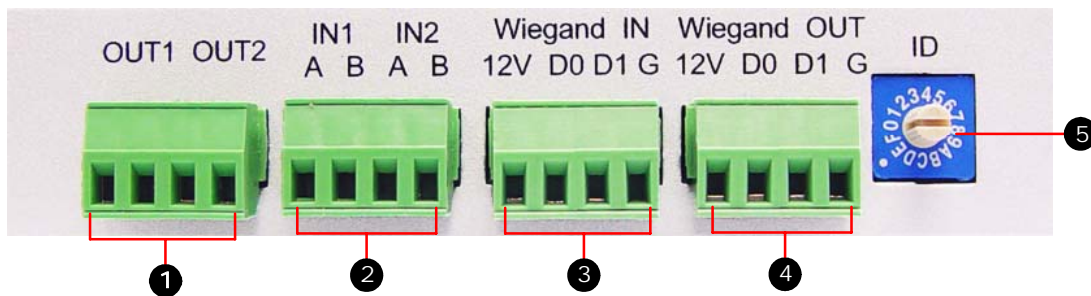

Figure 2-1

No.	Name	Function
1	Output Terminal Block	Support 2 relay outputs.
2	Input Terminal Block	Support 2 digital inputs.
3	Wiegand In Terminal Block	Input Wiegand signal.
4	Wiegand Out Terminal Block	Output Wiegand signal.
5	ID Switch	Up to 16 GV-Wiegand Capture Boxes can connect to one GV-System. 16 IDs from 0 ~ 9 and A ~ F are available for setup.

## 2.2 Rear Panel

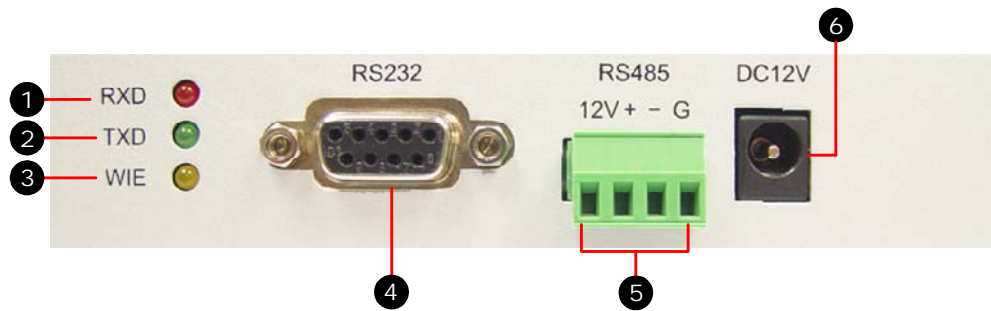

Figure 2-2

No.	Name	Function
1	Receive Data LED	This LED is on, indicating that data is received by the GV-System.
2	Transmit Data LED	This LED is on, indicating the data is transmitted to the GV-System.
3	Wiegand LED	This LED is on, indicating the Wiegand data is transmitted.
4	RS-232 Connector	Connect to the GV-System.
5	RS-485 Terminal Block	Connect to the GV-System.
6	DC IN 12V Power	A plug for power input.

# 3. Connections

This chapter includes four diagrams of connecting the access control system to the GV-System through the GV-Wiegand Capture.

## 3.1 Connecting GV-System through RS-232

When the physical distance between the GV-Wiegand Capture and the GV-System is less than 10 meters (32 ft), use the supplied RS-232 cable for connection.

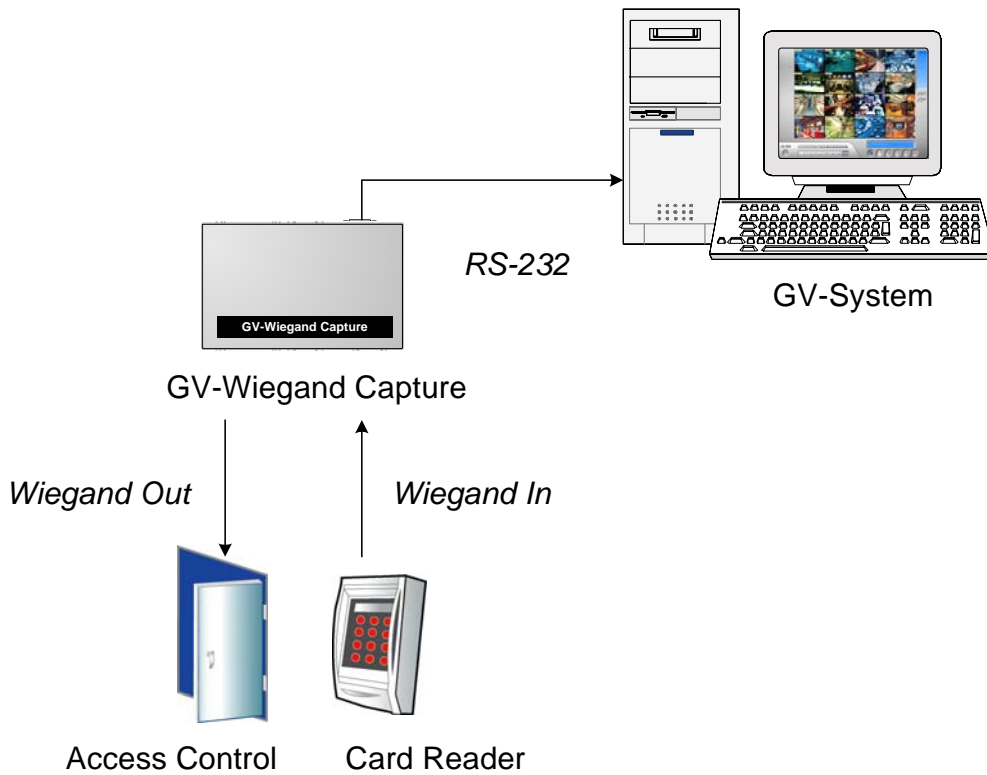

Figure 3-1

### 3.2 Connecting GV-System through RS-485

When the physical distance between the GV-Wiegand Capture and the GV-System is greater than 10 meters (32 ft), it is required to use (1) GV-NET series or (2) GV-Hub / GV-COM in the RS-485 connection.

---

**Note:** The maximum distance of RS-485 is 600 meters (2000 ft).

---

#### Using GV-NET series in the connection:

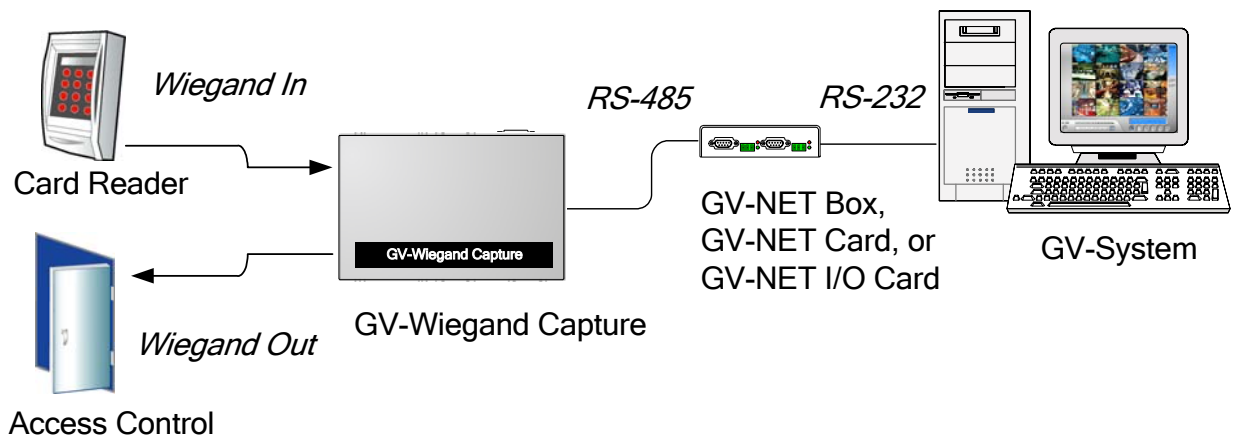

Figure 3-2

#### Using GV-Hub / GV-COM in the connection:

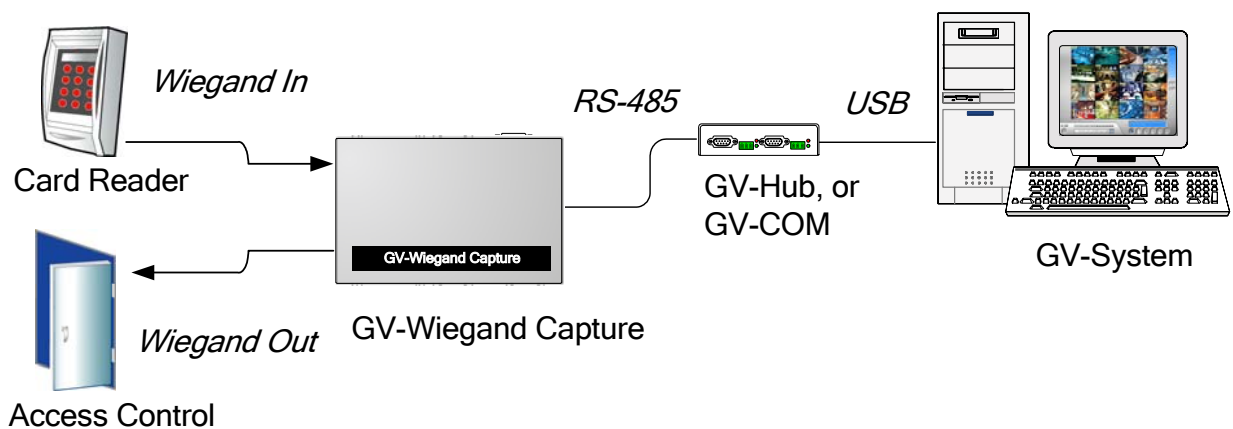

Figure 3-3

### 3.3 Connecting Multiple GV-Wiegand Capture Boxes

Through multiple GV-Wiegand Capture Boxes, you can connect up to 16 access control systems to a single GV-System.

For the connection of multiple GV-Wiegand Capture Boxes, there are distance limits and requirements for RS-485 communication:

1. If the physical distance between the GV-Wiegand Capture and GV-System is **within 100 meters (328 ft)**, use the general RS-485 cable.
2. If the physical distance between the GV-Wiegand Capture and GV-System is **within 100-300 meters (328 ~ 984 ft)**, we recommend using the RS-485 cable with characteristic impedance of 1KHz 120 ohms, defined by EIA-485 specifications.

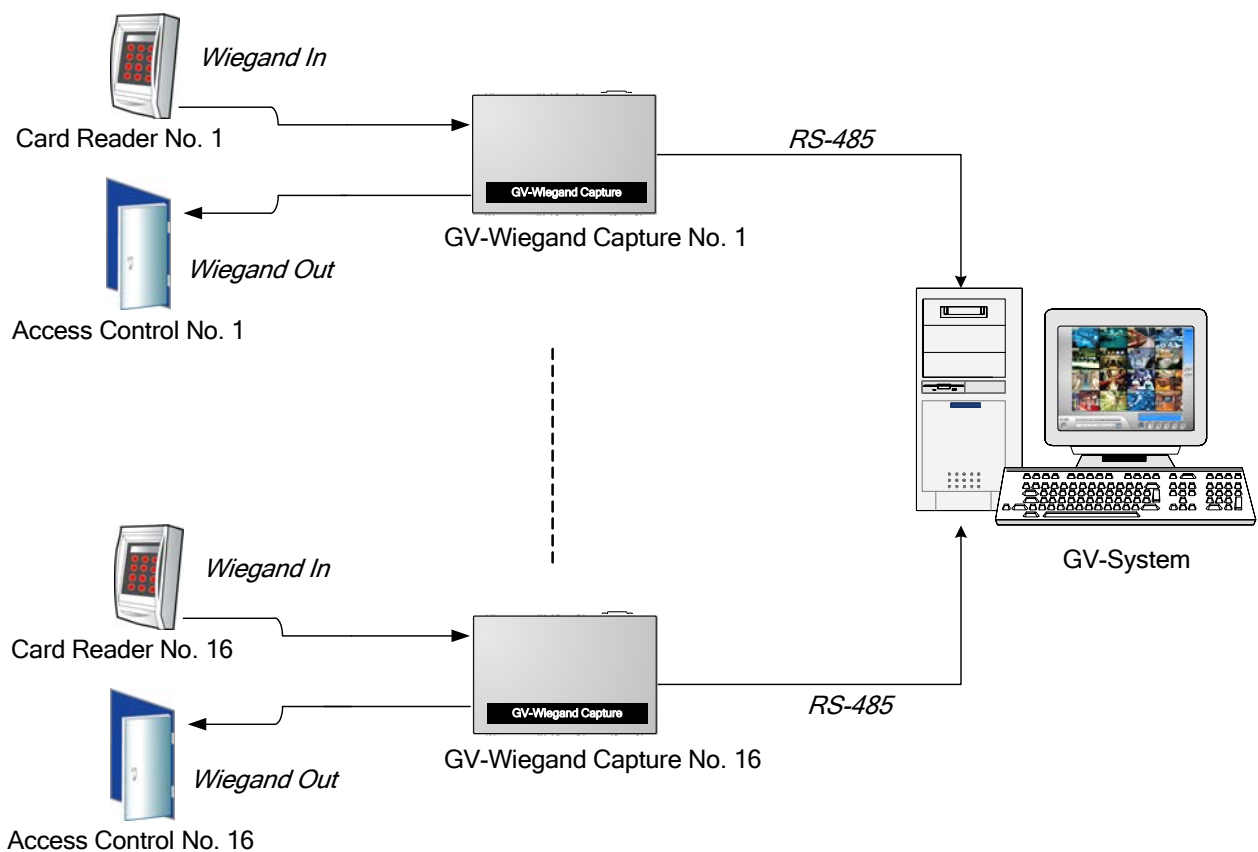

Figure 3-4

## 4. DVR Configurations

After connections, you must configure the GV-System before it can overlay access data on the surveillance video.

### 4.1 Device Setting

To add the access control system to the GV-System, follow these steps:

1. Click the **Configure** button, and select **GV Wiegand Capture Device Setting**. This dialog box appears.

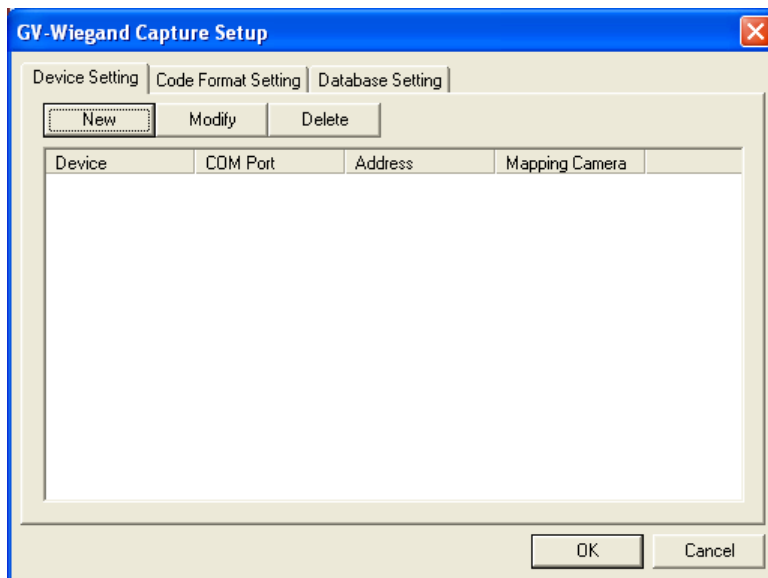

Figure 4-1

2. Click the **New** button. This dialog box appears.

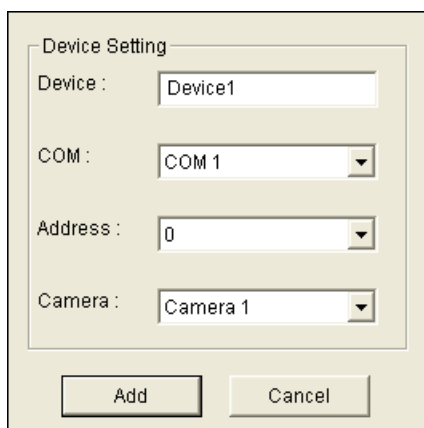

Figure 4-2

- **Device:** Give a name to the access control system.
  - **COM:** Select the COM port connected to the GV-Wiegand Capture.
  - **Address:** Select the ID of the connected GV-Wiegand Capture from 0 to 9 and A to F. The address should match the ID setting on the front panel of the GV-Wiegand Capture.
  - **Camera:** Assign the access control system to a channel on which access data would overlay.
3. After above settings, click **Add** to add the access control system to the GV-System.

## 4.2 Code Format Setting

The default code format is set to 26-bit and 37-bit Wiegand formats. If your access control system is not either of the two formats, click the **Code Format** drop-down list, select **Customized**, and click the **Add** button to define your Wiegand format.

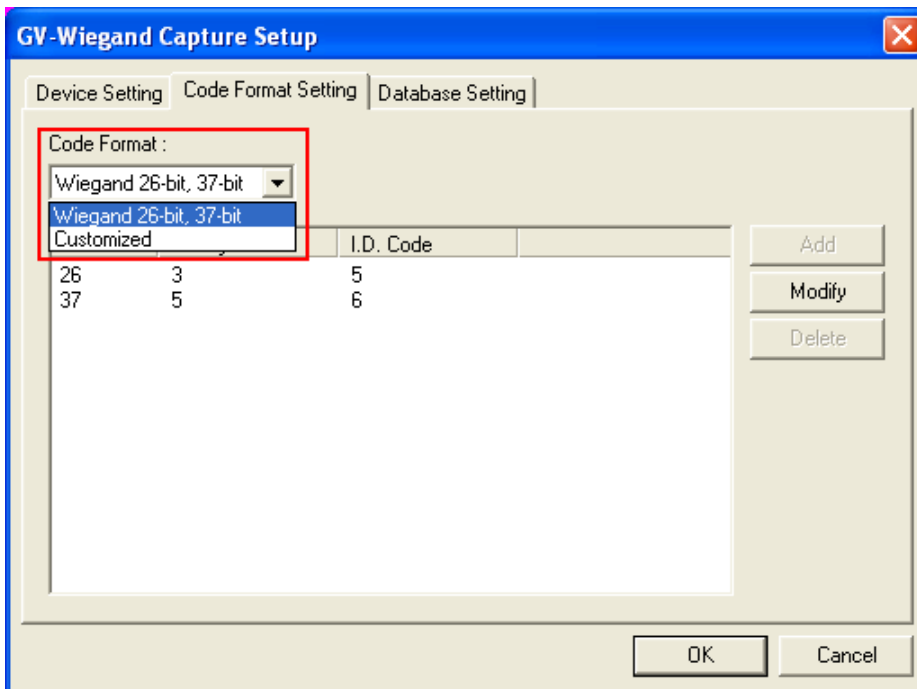

Figure 4-3



### 4.3 Database Connection Setting

The GV-Wiegand Capture provides you with a GV-Wiegand Capture Database to manage and store data. In addition, it supports the connection to a third-party database through the Microsoft Open Database Connectivity (ODBC) interface.

#### Setting up GV-Wiegand Capture Database

To set up the database, check the **Use GV-Wiegand Capture Database** option, and then click the **Database Setup** button to have these options.

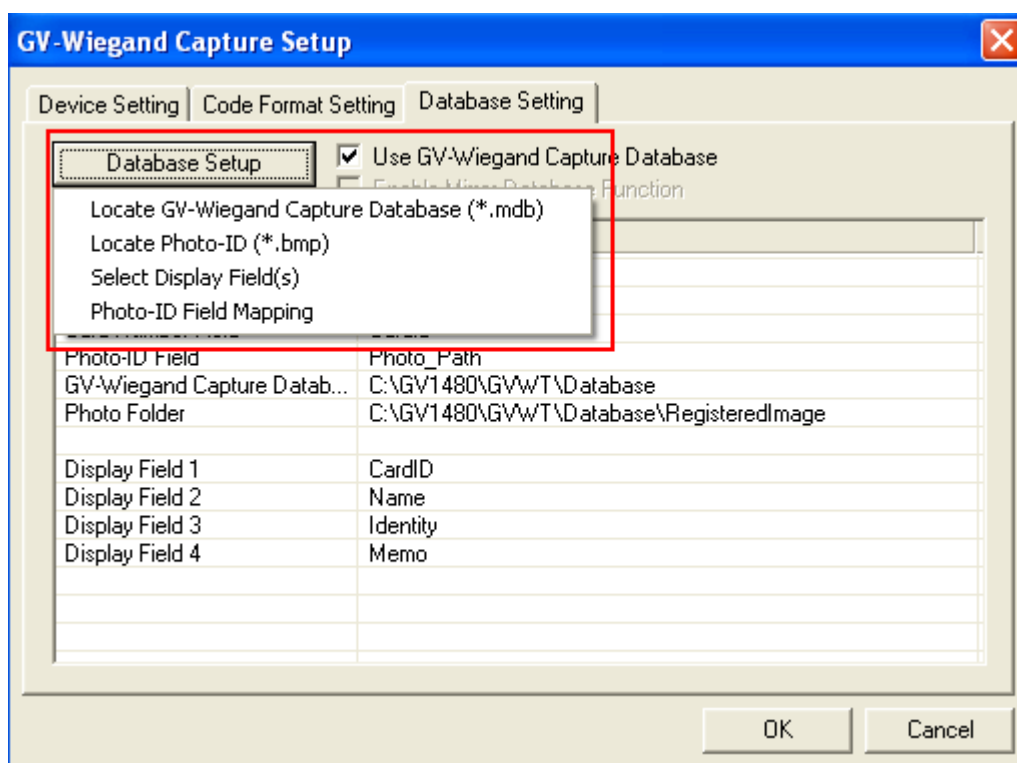

Figure 4-4

- **Locate GV-WT Database:** Assign the database path.
- **Locate Photo-ID:** Assign the photo path. Please note the maximum of image size should be 100 x 100 pixels in BMP format.
- **Select Display Field(s):** Specify the display fields on the screen, such as Card ID, Identity, Name and Memo (see *Figure 4-9*).
- **Photo-ID Field Mapping:** Select the photo-ID field so that the database can map the photo's ID to its corresponding photo (see *Figure 4-8*).

## Creating a Microsoft ODBC Connection:

The GV-Wiegand Capture supports the connection to a third-party database, such as Microsoft Access and a spreadsheet, through the Microsoft ODBC interface, providing you another option to access information. To create an ODBC connection, follow these steps:

1. In the Database Setting tab, uncheck **Use GV-Wiegand Capture Database**. This dialog box appears.

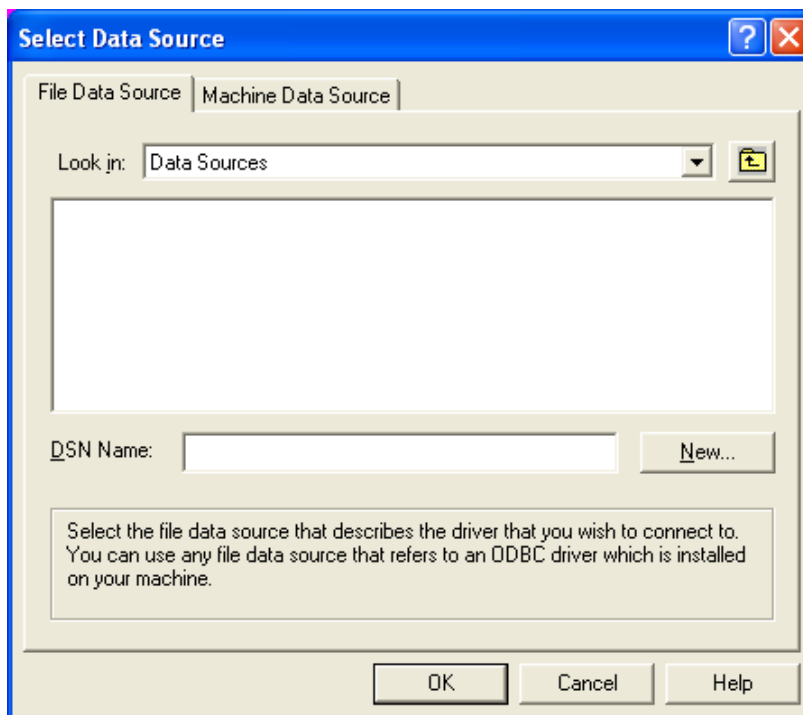

Figure 4-5

2. If the data source connection information is already installed on the computer, click the **Machine Data Source** tab to select the desired file.

If not, click the **File Data Source** tab, use the drop-down list to locate the DSN file, or click **New** to create a new file data source, and then click **OK**. This dialog box appears.

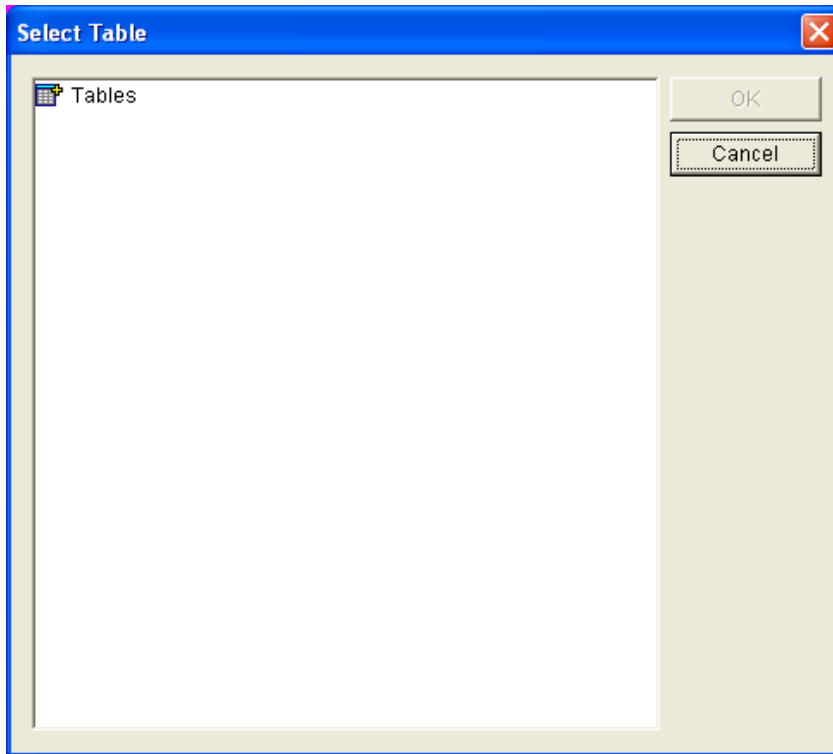

Figure 4-6

- Expand **Tables** and then select the desired table. This dialog box appears.

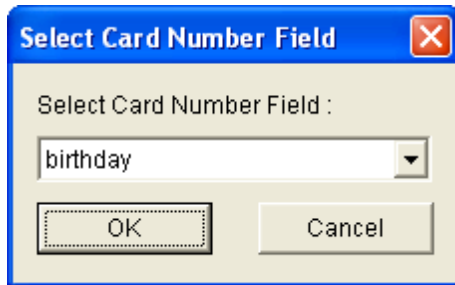

Figure 4-7

- The selections correspond to the categories set in the DSN file. Use the drop-down list to select the Card Number field, and click **OK**. This dialog box appears.



Figure 4-8

5. If you want to display the Photo-ID field, uncheck **No Photo-ID Field**, and click **OK**. This dialog box appears.

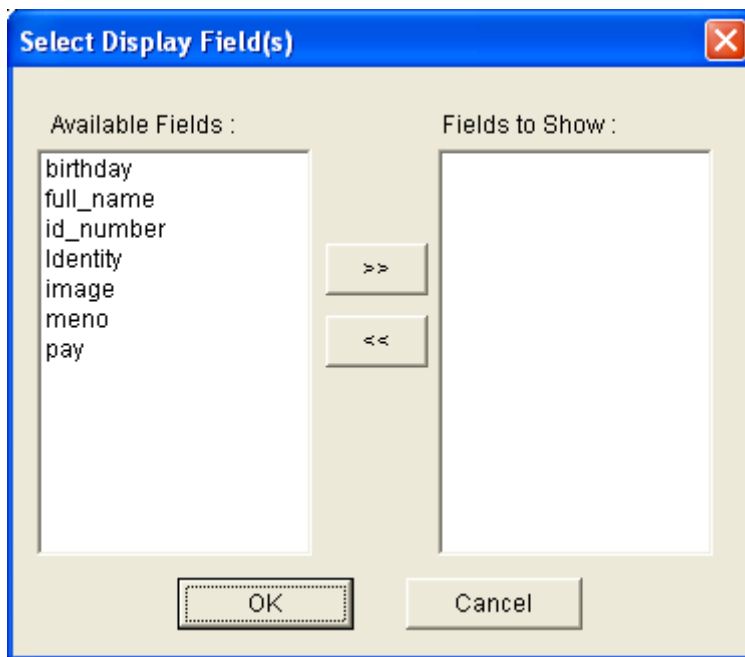

Figure 4-9

6. Select the fields to be displayed, click the **Right-Arrow** button and then click **OK**. A warning message appears.

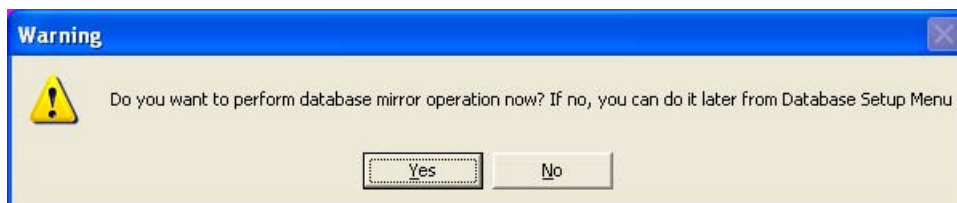

Figure 4-10

7. Click **Yes** to set up the backup file. **Enable Mirror Database Function** is then enabled.
8. In the Database Setting tab, click the **Database Setup** button (see *Figure 4-4*) to have these options.

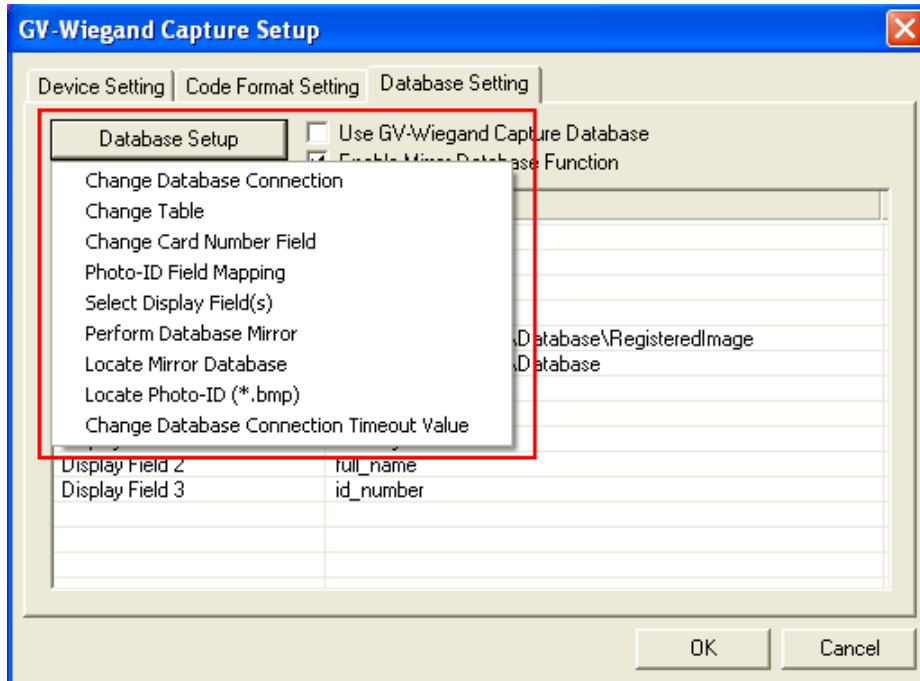

Figure 4-11

- **Change Database Connection:** Change the data source (see Figure 4-5).
- **Change Table:** Select another table to retrieve information (see Figure 4-6).
- **Change Card Number Field:** Change the previous setting of the Card Number field (see Figure 4-7).
- **Photo-ID Field Mapping:** Select the photo-ID field so that the database can map the photo's ID to its corresponding photo (see Figure 4-8).
- **Select Display Field(s):** Specify the display fields on the screen, such as Card ID, Identity, Name and Memo (see Figure 4-9).
- **Perform Database Mirror:** Replicate the existing database.
- **Locate Mirror Database:** Assign the backup database file path.
- **Locate Photo-ID (\*.bmp):** Assign the photo path. Please note the maximum of image size should be 100 x 100 pixels in BMP format.
- **Change Database Connection Timeout Value:** The GV-Wiegand Capture supports the connection to the DSN file over the Internet. Use this option to set the time length for the database connection. The maximum time length is 15 seconds.

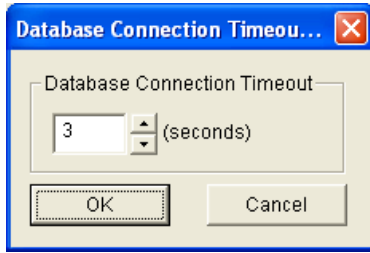

Figure 4-12

## 4.4 Text Overlay Setting

You can overlay and position the access data, such as Card ID, Identity, Name, Memo and photo, onto the surveillance video. To access this feature, click the **Configure** button and select **Text Overlay Setting**.

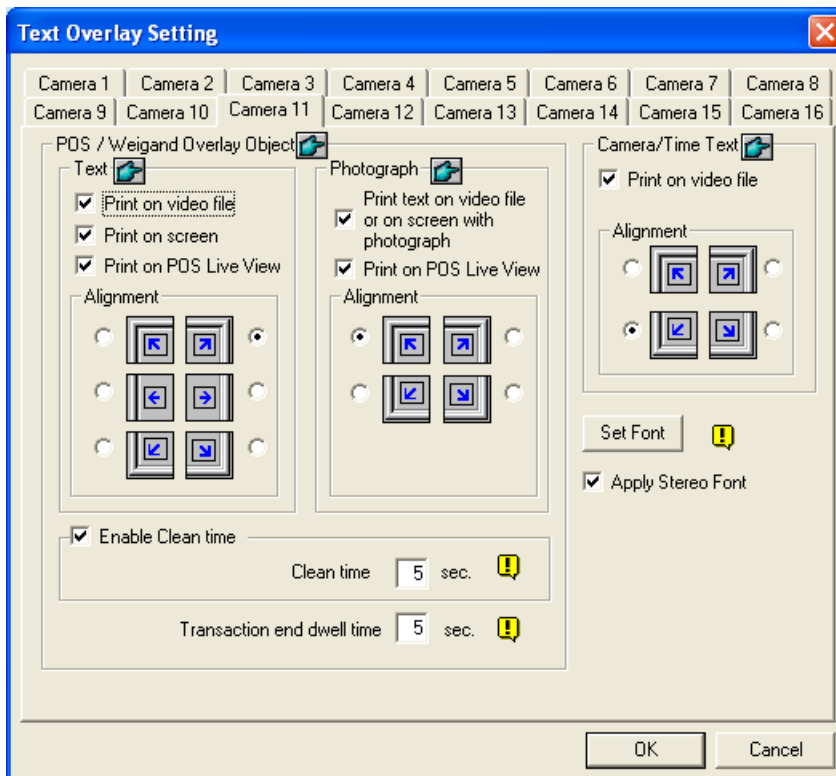

Figure 4-13

### [ POS / Wiegand Overlay Object ]

- **Print on video file:** Overlays the cardholder's data onto the recorded file.
- **Print on screen:** Overlays the cardholder's data onto the live video.
- **Print on POS Live View:** Displays the cardholder's data on the separate POS Live View window (see Figure 4-14).

- **Alignment:** Sets the position of text overlay on the screen.

#### [ Photograph ]

- **Print text on video file or on screen with photograph:** Overlays the photo with access data onto the live video or the recorded file.
- **Print on POS Live View:** Displays the photo on the separate POS Live View window (See *Figure 4-14*).
- **Alignment:** Sets the position of photo overlay on the screen.

#### [ Camera/Time Text ]

- **Print on video file:** Overlays the camera ID, location name, date and time onto the recorded file.
- **Alignment:** Sets the position of Camera/Time text overlay on the screen.

**[ Set Font ]** Sets the font for text overlay. The option **Apply Stereo Font** makes text stand out from the background by giving white-edge to the text.



Figure 4-14 Overlaying access data on the POS Live View window

## 5. I/O Setting

One GV-Wiegand Capture supports two I/O devices. After setting up a GV-Wiegand Capture, you can configure and control the I/O devices connected to the GV-Wiegand Capture.

1. Click the **Configure** button, point to **I/O Application**, and select **Virtual I/O Setting**. This dialog box appears.

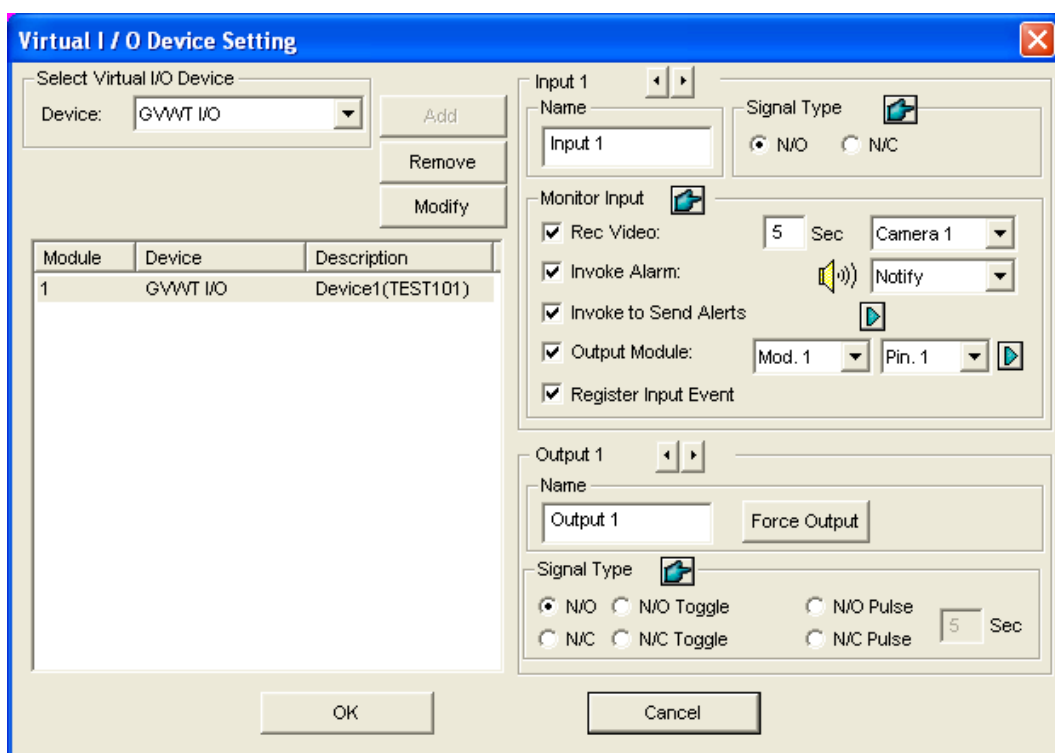

Figure 5-1



- In the Select Virtual I/O Device field, use the drop-down list to select **GVWT I/O**, and then click the **Add** button. This dialog box appears.

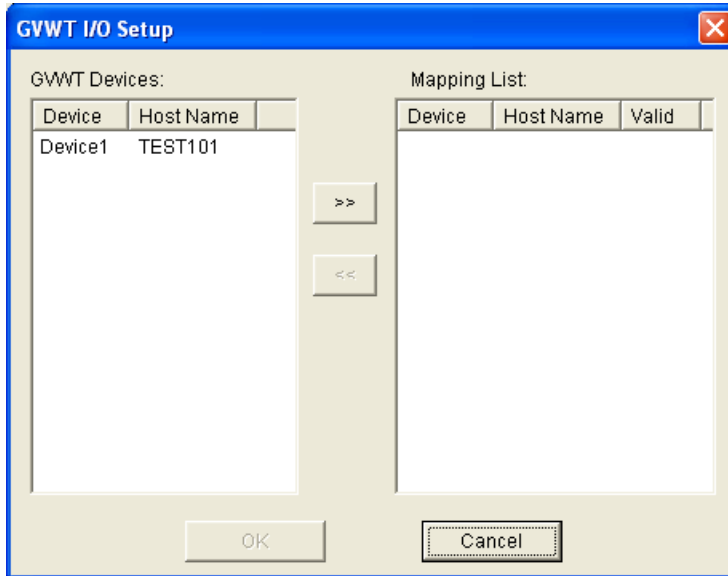

Figure 5-2

- Select the GV-Wiegand Capture, and click the right-arrow button to add this device to the Mapping List.
- Click **OK** to save the settings and return to the Virtual I/O Device Setting dialog box (See Figure 5-1).

[ **Input X** ] One GV-Wiegand Capture supports 2 inputs. Click the **Arrow** buttons to select an Input.

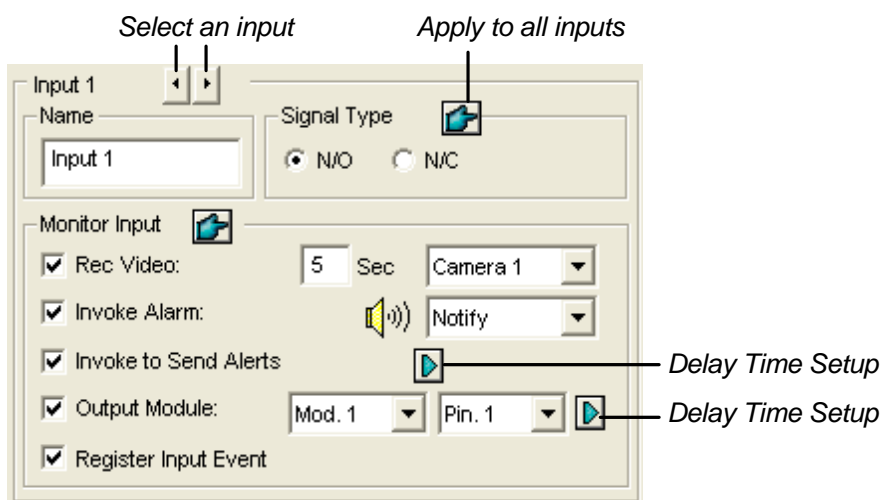

Figure 5-3

- **Name:** Name the selected input device in the Name field.

- **Signal Type:** Select **N/O** or **N/C** for your input device. You may use the **Finger** button to apply your selection to all input devices.

#### [ Monitor Input ]

- **Rec Video:** Check this option to use the input (sensors or detectors) to trigger recording. You may select which camera to record in the Camera Select drop-down list and specify the recording duration.
- **Invoke Alarm:** Check this option to activate computer alarm when the input is triggered. You may select the alarm type in the drop-down menu.
- **Invoke to Send Alerts:** Check this option to send out an assigned alert (E-Mail/Hotline/SMS) when the input is triggered.

**Right-Arrow button:** Click to set the delay time to activate assigned alerts (E-Mail/Hotline/SMS).

- **Output Module:** If the input is invoked, the system will automatically send a signal to an output pin.

**Right-Arrow button:** Click to set the delay time to activate the assigned output module.

---

**Note:** The delay functions in **Invoke to Send Alerts** and **Output Module** allow you time to deactivate prior alert and output settings. To deactivate these settings, you may stop monitoring or enable the assigned input module set at “**Deactivate notification when selected pin ON**” in I/O Application Setting.

---

- **Register Input Event:** This option logs the alarm events into System Log. Each event is labeled with ID, time, device name (camera or I/O input), corresponding module of the device, and event for later retrieval. For details on *System Log*, see Chapter 1, *User's Manual* on the Surveillance System Software CD.

[ **Output X** ] One GV-Wiegand Capture supports 2 outputs. Click the **Arrow** buttons to select an Output.

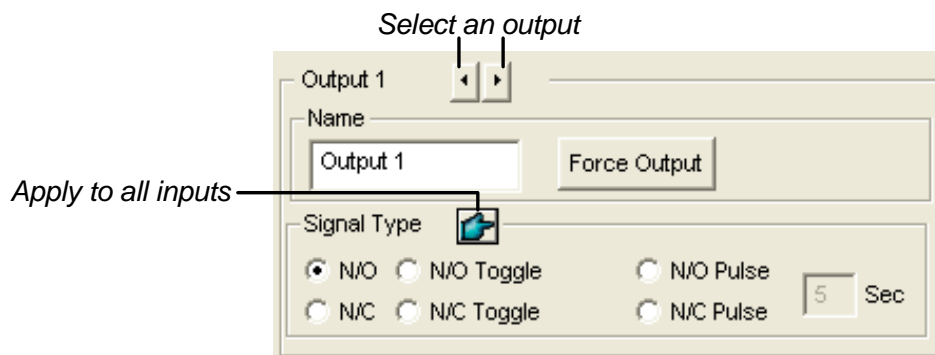

Figure 5-4

- **Name:** Name the selected output device in the Name field.
- **Force Output:** Click to test signal to the selected device.
- **Signal Type:** There are six signal types available: N/O (Normal Open), N/O Toggle, N/O Pulse, N/C (Normal Closed), N/C Toggle, and N/C Pulse. Choose the one that mostly suits the device you're using. The N/O Toggle or N/C Toggle signal type is the output high mode that turns to output low until the monitoring is stopped. You can also specify the pulse duration for pulse type signals.

---

**Note:** PTZ camera and I/O devices cannot be assigned to the same port at the same time.

---

## 6. Input Configurations

The GV-Wiegand Capture accepts input devices of dry contact or wet contact. Input 1 and 2 are set to be dry contact by default. To change the inputs to wet contact, open the casing and push the white switch downward.

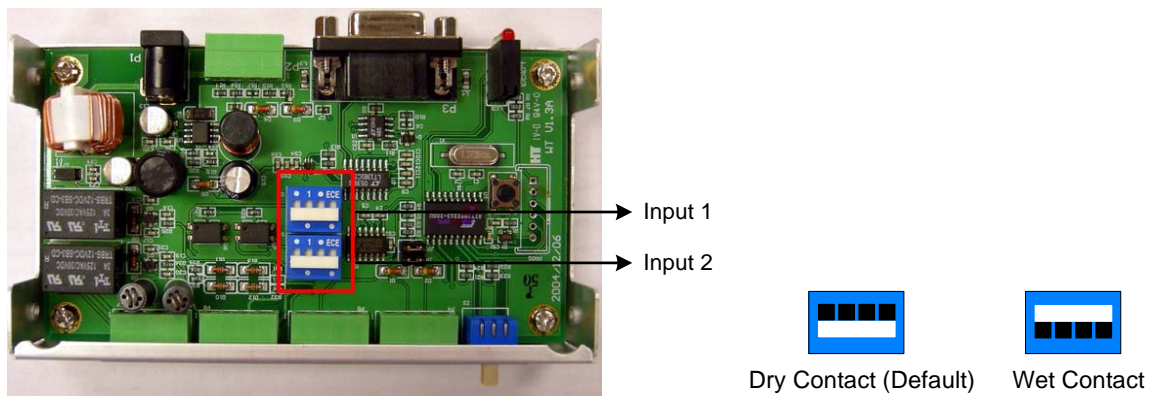

Figure 6-1

# 7. Specifications

Communication	RS-232	DB9 Female
	RS-485	Terminal Block
Input	Input	2
	Input Signal	12V Voltage input / dry-connect input
	High State	9~12V / close
	Low State	0V / open
Output	Relay Output	2
	Relay Status	Normal Open
	Relay Capacitance	3A / VAC125V, 1.5A / VAC250V
	Relay ON Time	4ms
	Relay OFF Time	4ms
Wiegand	Input Connector	12V, D0, D1, GND
	Output Connector	12V, D0, D1, GND
	Format	Wiegand 26 Bits~40 Bits
DC IN		DC 12V, 1A
Environmental Condition		0~55°C (32~104°F), 5%~95% (non-condensing)
Dimension		120mm (W) x 68mm (H) x 26mm (D)