

# GV-Compact DVR V3

## *User's Manual*



Before attempting to connect or operate this product,  
please read these instructions carefully and save this manual for future use.

CDVR3-4CHV104-8CHV102-B



© 2014 GeoVision, Inc. All rights reserved.

Under the copyright laws, this manual may not be copied, in whole or in part, without the written consent of GeoVision.

Every effort has been made to ensure that the information in this manual is accurate. GeoVision, Inc. makes no expressed or implied warranty of any kind and assumes no responsibility for errors or omissions. No liability is assumed for incidental or consequential damages arising from the use of the information or products contained herein. Features and specifications are subject to change without notice.

GeoVision, Inc.  
9F, No. 246, Sec. 1, Neihu Rd.,  
Neihu District, Taipei, Taiwan  
Tel: +886-2-8797-8377  
Fax: +886-2-8797-8335  
<http://www.geovision.com.tw>

Trademarks used in this manual: *GeoVision*, the *GeoVision* logo and *GV* series products are trademarks of GeoVision, Inc. *Windows* and *Windows XP* are registered trademarks of Microsoft Corporation.

January 2014

# Preface

Welcome to the *GV-Compact DVR V3 User's Manual*.

The GV-Compact DVR V3 has a series of models designed to meet different needs. This Manual is designed for the following models and firmware version:

## The Four-Channel Unit

Models	Model Name	Firmware Version
Standard Models	GV-LX4C3D1	1.04
	GV- LX4C3D2	
	GV- LX4C3D2W	
Anti-Vibration ACC Model	GV-LX4C3V	

## The Eight-Channel Unit

Models	Model Name	Firmware Version
Standard Models	GV-LX8CD1	1.02
	GV-LX8CD2	
	GV-LX8CD2W	
Anti-Vibration ACC Models	GV-LX8CV1	
	GV-LX8CV2	

---

**IMPORTANT:** For better recording efficiency and stability of GV-Compact DVR V3, after upgrading the firmware to the above versions, it is required to **format the storage device**. To format the storage device, be sure to back up the data first and see [3.7 Formatting Hard Drive](#) for how to format the storage device.

---

# Contents

<b>Chapter 1 Introduction .....</b>	<b>1</b>
<b>1.1 Features .....</b>	<b>2</b>
<b>1.2 Models .....</b>	<b>3</b>
1.2.1 The Four-Channel Unit .....	3
1.2.2 The Eight-Channel Unit .....	4
<b>1.3 Packing List.....</b>	<b>5</b>
1.3.1 The Four-Channel Unit .....	5
1.3.2 The Eight-Channel Unit .....	7
<b>1.4 Options .....</b>	<b>9</b>
<b>1.5 System Requirement.....</b>	<b>10</b>
<b>Chapter 2 Physical Description .....</b>	<b>11</b>
<b>2.1 Front Panel .....</b>	<b>11</b>
2.1.1 The Four-Channel Unit .....	11
2.1.2 The Eight-Channel Unit .....	14
<b>2.2 Rear Panel .....</b>	<b>18</b>
2.2.1 The Four-Channel Unit .....	18
2.2.2 The Eight-Channel Unit .....	20
<b>2.3 Remote Control .....</b>	<b>22</b>
2.3.1 The Four-Channel Unit .....	22
2.3.2 The Eight-Channel Unit .....	24
<b>Chapter 3 Getting Started .....</b>	<b>26</b>
<b>3.1 Basic Connection for Standard Models.....</b>	<b>27</b>
3.1.1 The Four-Channel Unit .....	27
3.1.2 The Eight-Channel Unit .....	28
<b>3.2 Basic Connection for Anti-Vibration Models.....</b>	<b>29</b>
3.2.1 The Four-Channel Unit .....	29
3.2.2 The Eight-Channel Unit .....	30
<b>3.3 Connecting Anti-Vibration ACC Models .....</b>	<b>31</b>
3.3.1 Connecting and Testing .....	31
3.3.2 Connecting to a vehicle .....	33
<b>3.4 Connecting Optional Video Output Devices.....</b>	<b>38</b>
3.4.1 The Four-Channel Unit .....	38
3.4.2 The Eight-Channel Unit .....	39
<b>3.5 Installing a Hard Drive .....</b>	<b>40</b>
3.5.1 The Four-Channel Unit .....	40
3.5.2 The Eight-Channel Unit .....	43
<b>3.6 Turning On / Off the Power.....</b>	<b>45</b>

3.6.1	Turning On the Power.....	45
3.6.2	Turning Off the Power.....	45
<b>3.7</b>	<b>Formatting Hard Drive .....</b>	<b>46</b>
<b>3.8</b>	<b>Main Screen Overview .....</b>	<b>47</b>
<b>3.9</b>	<b>Basic Operation.....</b>	<b>48</b>
3.9.1	Date/Time Adjustment .....	48
3.9.2	Recording Operation.....	48
3.9.3	Search/Playback Operation .....	49
3.9.4	PTZ Operation .....	49
3.9.5	Channel Number and Camera Name.....	49
3.9.6	Video Backup .....	49

## **Chapter 4    OSD Menu Configurations .....50**

<b>4.1</b>	<b>Channel Settings.....</b>	<b>52</b>
4.1.1	Channel Name.....	52
4.1.2	Video/Audio Settings .....	53
4.1.3	Motion Detection.....	54
4.1.4	Motion Trigger Output Settings .....	56
4.1.5	Alarm Settings .....	57
4.1.6	Camera Settings.....	57
4.1.7	PTZ Settings.....	58
4.1.8	PTZ Control .....	59
4.1.9	Privacy Mask .....	60
<b>4.2</b>	<b>Digital IO Settings .....</b>	<b>61</b>
4.2.1	Digital Input Settings.....	61
4.2.2	Digital Output Settings .....	62
4.2.3	GPS Settings.....	63
<b>4.3</b>	<b>Events and Alerts.....</b>	<b>65</b>
4.3.1	E-mail.....	66
4.3.2	FTP .....	67
4.3.3	Center V2 .....	68
4.3.4	VSM.....	69
4.3.5	GV-GIS.....	70
4.3.6	Video Gateway / Recording Server .....	71
4.3.7	Remote Playback.....	72
4.3.8	3GPP .....	73
<b>4.4</b>	<b>Monitoring Settings.....</b>	<b>74</b>
<b>4.5</b>	<b>Recording Schedule.....</b>	<b>76</b>
4.5.1	Specific Day.....	76
4.5.2	Channel Schedule .....	77
4.5.3	I/O Monitoring Schedule .....	78
<b>4.6</b>	<b>Search / Playback.....</b>	<b>79</b>
4.6.1	Time Map List .....	79
4.6.2	List All.....	80
4.6.3	Manual Recording List .....	80

4.6.4	Alarm Recording List .....	80
4.6.5	Motion Recording List .....	80
4.6.6	Time Search .....	80
4.6.7	Advanced Search .....	81
<b>4.7</b>	<b>Network.....</b>	<b>82</b>
4.7.1	Network Status .....	82
4.7.2	Connection Settings.....	83
4.7.3	Wireless Settings.....	84
4.7.4	Advanced TCP/IP .....	85
4.7.5	UMTS Settings .....	86
4.7.6	DDNS Settings .....	87
4.7.7	Multicast Settings .....	88
4.7.8	Web User Account Info.....	89
<b>4.8</b>	<b>Advanced.....</b>	<b>90</b>
4.8.1	Date and Time .....	90
4.8.2	Firmware Settings.....	91
4.8.3	Storage Settings .....	92
4.8.4	Display Settings.....	93
4.8.5	Spot Monitor Settings .....	94
4.8.6	Alert Settings .....	95
4.8.7	System Settings.....	96
4.8.8	System Log.....	97
4.8.9	Backup .....	98

## **Chapter 5 Remote Viewing Using A Web Browser.....99**

<b>5.1</b>	<b>Assigning an IP Address .....</b>	<b>99</b>
5.1.1	Using OSD Menu.....	99
5.1.2	Connecting with a PC .....	100
<b>5.2</b>	<b>Accessing Your Surveillance Images .....</b>	<b>103</b>
<b>5.3</b>	<b>Functions Featured on the Main Page.....</b>	<b>104</b>
5.3.1	The Live View Window .....	105
5.3.2	The Control Panel of the Live View Window .....	106
5.3.3	Snapshot of a Live Video .....	107
5.3.4	Video Recording .....	107
5.3.5	Picture-in-Picture and Picture-and-Picture View .....	108
5.3.6	Alarm Notification.....	110
5.3.7	Video and Audio Configuration .....	111
5.3.8	Remote Configuration.....	111
5.3.9	Camera Name Display.....	111
5.3.10	Image Enhancement.....	112
5.3.11	PTZ Control .....	112
5.3.12	Visual PTZ.....	113
5.3.13	I/O Control .....	114
5.3.14	Visual Automation.....	115
5.3.15	Multicast .....	116

5.3.16	Network Status .....	117
--------	----------------------	-----

## **Chapter 6 Remote Configurations .....118**

<b>6.1</b>	<b>Video &amp; Motion .....</b>	<b>120</b>
6.1.1	Video Settings .....	120
6.1.2	Motion Detection .....	124
6.1.3	Text Overlay .....	125
6.1.4	Visual Automation .....	126
6.1.5	VGA Output Settings .....	127
6.1.6	Video Channel Source Settings .....	127
<b>6.2</b>	<b>Digital I/O &amp; PTZ .....</b>	<b>128</b>
6.2.1	I/O Control .....	128
6.2.2	PTZ Settings .....	130
6.2.3	GPS .....	131
6.2.4	Buzzer .....	133
6.2.5	Spot Monitor .....	134
<b>6.3</b>	<b>Events &amp; Alerts .....</b>	<b>135</b>
6.3.1	E-mail .....	136
6.3.2	FTP .....	137
6.3.3	Center V2 .....	139
6.3.4	VSM .....	141
6.3.5	GV-GIS .....	143
6.3.6	Backup Center .....	145
6.3.7	Video Gateway / Recording Server .....	147
6.3.8	ViewLog Server .....	149
6.3.9	RTSP / 3GPP .....	150
<b>6.4</b>	<b>Monitoring .....</b>	<b>151</b>
<b>6.5</b>	<b>Recording Schedule .....</b>	<b>153</b>
6.5.1	Recording Schedule Settings .....	153
6.5.2	I/O Monitoring Settings .....	154
<b>6.6</b>	<b>Remote ViewLog .....</b>	<b>155</b>
<b>6.7</b>	<b>Network .....</b>	<b>156</b>
6.7.1	LAN .....	156
6.7.2	Wireless-Client Mode .....	159
6.7.3	Advanced TCP/IP .....	161
6.7.4	UMTS/ZigBee .....	164
6.7.5	Multicast .....	166
6.7.6	IP Filtering .....	168
6.7.7	SNMP Setting .....	169
<b>6.8</b>	<b>Management .....</b>	<b>170</b>
6.8.1	Date & Time Setting .....	170
6.8.2	GPS Maps Settings .....	172
6.8.3	Storage Settings .....	173
6.8.4	User Account .....	175
6.8.5	Log Information .....	176
6.8.6	Tools .....	177

6.8.7	ACC Settings .....	179
<b>Chapter 7</b>	<b>Remote Recording and Playback .....</b>	<b>180</b>
7.1	Remote Recording .....	180
7.2	Remote Playback .....	180
7.2.1	Playback of Files Recorded on Hard Drive.....	181
7.2.2	Playback over Network .....	185
7.2.3	Access to the Recorded Files through FTP Server .....	186
7.2.4	Playback of Backup Files.....	186
7.2.5	Playback of GPS Tracks .....	188
<b>Chapter 8</b>	<b>Advanced Applications .....</b>	<b>191</b>
8.1	Upgrading System Firmware.....	191
8.1.1	Using the Web Interface .....	192
8.1.2	Using the IP Device Utility.....	193
8.2	Backing Up and Restoring Settings.....	195
8.2.1	Backing Up the Settings.....	195
8.2.2	Restoring the Settings .....	196
8.3	GPS Tracking.....	197
8.4	Restoring to Factory Default Settings .....	199
8.5	Verifying Watermark .....	200
8.5.1	Accessing the Recorded Files.....	200
8.5.2	Running Watermark Proof .....	200
8.5.3	The Watermark Proof Window .....	201
<b>Chapter 9</b>	<b>Smart Device Surveillance .....</b>	<b>202</b>
9.1	Android Smartphones and Tablets .....	203
9.1.1	Connecting to GV-Compact DVR V3 .....	204
9.2	iPhone iPod Touch and iPad .....	206
9.2.1	Connecting to GV-Compact DVR V3 .....	207
<b>Chapter 10</b>	<b>DVR Configurations .....</b>	<b>209</b>
10.1	Setting up GV-Compact DVR V3 .....	210
10.2	Remote Monitoring with Multi View .....	214
10.3	Remote Monitoring with E-Map .....	216
<b>Chapter 11</b>	<b>CMS Configurations.....</b>	<b>218</b>
11.1	Center V2 .....	218
11.2	VSM.....	220
11.3	Dispatch Server.....	221
11.4	Control Center .....	222



**Chapter 12 The I/O Terminal Block .....224**

**12.1 Pin Assignment.....224**  
12.1.1 The Four-Channel Unit .....224  
12.1.2 The Eight-Channel Unit .....225  
**12.2 Output Devices.....226**  
12.2.1 The Four-Channel Unit .....226  
12.2.2 The Eight-Channel Unit .....227  
**12.3 Camera Power Supply .....229**  
12.3.1 The Four-Channel Unit .....229  
12.3.2 The Eight-Channel Unit .....230

**Specifications: The Four-Channel Unit .....231**

**Specifications: The Eight-Channel Unit .....235**

**Appendix.....239**

**A. Supported Wireless LAN USB Adaptor .....239**  
**B. Supported Mobile Broadband Device .....239**  
**C. Settings for Internet Explore 8 or later .....240**  
**D. The CGI Command .....241**  
**E. The RTSP Command .....242**  
**F. Supported PTZ Cameras .....243**  
**G. Default Port Value .....245**

# Chapter 1 Introduction

The GV-Compact DVR V3 is a mobile video recorder that comes in the four-channel and eight-channel units. The four-channel unit can simultaneously display real-time images from four cameras, while the eight-channel unit can simultaneously display real-time images from eight cameras.

For four-channel unit, the recording frame rate of each channel is adjustable up to 30 / 25 fps at the resolution of 704 x 480 (NTSC) / 704 x 576 (PAL). For eight-channel unit, the recording frame rate of each channel is adjustable up to 15 / 12.5 fps at the resolution of 704 x 480 (NTSC) / 704 x 576 (PAL).

The Anti-Vibration ACC model of the GV-Compact DVR V3 has already been tested to withstand severe levels of shock and vibration in mobile environments. It is perfect to be installed in any vehicles, such as buses and vans, for surveillance and recording.

The special design of the GV-Compact DVR V3 enables you to link up with TV, VGA and spot monitors simultaneously for direct display. The GV-Compact DVR V3 offers many features that you can expect to have.

## 1.1 Features

- Four-channel / eight-channel video and audio recording
- Up to 120 fps at D1 resolution for four-channel / eight-channel units
- Independent channel resolution, quality and frame rate settings
- VGA output in high resolution (1280 x 1024)
- Simultaneous video display on TV, VGA and Spot Monitor
- Video retrieve by date, time and event
- Remote playback
- GPS Speed Text overlay on live view and recordings
- Continuous, motion detection, schedule and input-triggered recordings
- Buzzer alarm on video lost, input triggered, motion detected and disk full
- Mobile broadband (HSDPA, UMTS, EDGE, EVDO, etc.)
- Mobile Phone Surveillance (Android Smartphone, iPhone, iPad)
- Central monitoring systems Center V2, VSM, Control Center, Recording Server
- Geographic information system GV-GIS
- GPS tracking for the Anti-Vibration ACC models (GPS module required)
- 4 alarm inputs and outputs for the 4-channel unit; 8 alarm inputs and outputs for the 8-channel unit
- Support for 3.5" or 2.5" SATA HDD (3.5" to 2.5" HDD converter required)
- Support for External USB mass storage devices
- DVD-RW Backup
- Backup Center for PC-based storage and backup solution
- Support for 16 languages on Web interface





## 1.2 Models

The GV-Compact DVR V3 comes in the four-channel and eight-channel units. Each unit is available in the **Standard** models and the **Anti-Vibration ACC** models as listed below.





**IMPORTANT:**

1. Standard and Anti-Vibration ACC models have different internal designs. It is forbidden to connect the Standard model to vehicle power supply.
2. For the Anti-vibration ACC models (GV-LX4C3V, GV-LX8CV1 and GV-LX8CV2), it is necessary to use the hard drive especially for notebook, vehicle or surveillance applications, and tightly fasten the unit on the vehicle to prevent vibration and shock hazard.

### 1.2.1 The Four-Channel Unit

	Model Name	Image	Description
Standard models	GV-LX4C3D1		Equipped with 2 USB ports and 1 hard drive bay.
	GV- LX4C3D2		Equipped with 2 USB ports and 2 hard drive bays.
	GV- LX4C3D2W		Equipped with 2 USB ports, 1 hard drive bay and 1 DVD-RW drive.
Anti-Vibration ACC model	GV-LX4C3V		Equipped with vibration absorbers, 2 USB ports and 1 hard drive bay.

## 1.2.2 The Eight-Channel Unit

	Model Name	Image	Description
Standard models	GV-LX8CD1		Equipped with 4 USB ports and 1 hard drive bay.
	GV-LX8CD2		Equipped with 4 USB ports and 2 hard drive bays.
	GV-LX8CD2W		Equipped with 4 USB ports, 1 hard drive bay and 1 DVD-RW drive.
Anti-Vibration ACC models	GV-LX8CV1		Equipped with vibration absorbers, 4 USB ports and 1 hard drive bay.
	GV-LX8CV2		Equipped with vibration absorbers, 4 USB ports and 2 hard drive bays.

## 1.3 Packing List

If any of the items are missing or damaged, contact your dealer to arrange a replacement.



---

**Note:** The hard disk is not included in the standard package.



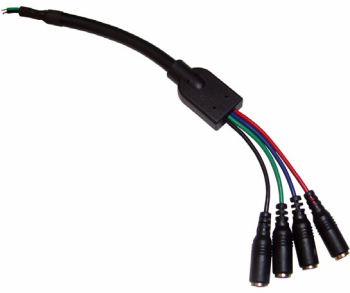

---

### 1.3.1 The Four-Channel Unit

- **Standard Models (GV-LX4C3D1 / GV-LX4C3D2 / GV-LX4C3D2W)**

<ul style="list-style-type: none"> <li>• D-Type Video Cable x 1</li> </ul> 	<ul style="list-style-type: none"> <li>• D-Type Audio/TV/Spot Monitor Cable x 1</li> </ul> 
<ul style="list-style-type: none"> <li>• Camera Power Cable x 1</li> </ul> 	<ul style="list-style-type: none"> <li>• Power Adaptor 12V, 5A x 1</li> <li>• AC Power Cord x 1</li> <li>• Lock Key x 2 (1 Bay), x 4 (2 Bays)</li> <li>• Round Screws x 6 (1 Bay), x 12 (2 Bays)</li> <li>• T-Cap Screw x 4 (1 Bay), x 8 (2 Bays)</li> <li>• Remote Control x 1</li> <li>• GV-Compact DVR Quick Start Guide x 1</li> <li>• GV-Compact DVR Software CD/DVD x 1</li> <li>• GV-NVR Quick Start Guide x 1</li> <li>• GV-NVR Software CD/DVD x 1</li> </ul>

- **Anti-Vibration ACC Model (GV-LX4C3V)**

<ul style="list-style-type: none"> <li>• D-Type Video Cable x 1</li> </ul> 	<ul style="list-style-type: none"> <li>• D-Type Audio/TV/Spot Monitor Cable x 1</li> </ul> 
<ul style="list-style-type: none"> <li>• Camera Power Cable x 1</li> </ul> 	<ul style="list-style-type: none"> <li>• Power Cable x 1</li> </ul> 
<ul style="list-style-type: none"> <li>• Shorting Cable x 1</li> </ul> 	<ul style="list-style-type: none"> <li>• Lock Key x 2 (1 Bay), x 4 (2 Bays)</li> <li>• Round Screws x 6 (1 Bay), x 12 (2 Bays)</li> <li>• T-Cap Screw x 4 (1 Bay), x 8 (2 Bays)</li> <li>• Remote Control x 1</li> <li>• GV-Compact DVR Quick Start Guide x 1</li> <li>• GV- Compact DVR Software CD/DVD x 1</li> <li>• GV-NVR Quick Start Guide x 1</li> <li>• GV-NVR Software CD/DVD x 1</li> </ul>

### 1.3.2 The Eight-Channel Unit

- **Standard Models (GV-LX8CD1 / GV-LX8CD2 / GV-LX8CD2W)**

- 1 to 5 D-Type Video Cable x 1



- 6 to 8 D-Type Video/TV/Spot Monitor Cable x 1



- Camera Power Cable x 2



- D-Type Audio Cable x 1



- Power Adaptor 12V, 5A x 1
- AC Power Cord x 1
- Lock Key x 2 (1 Bay), x 4 (2 Bays)
- Round Screws x 6 (1 Bay), x 12 (2 Bays)
- T-Cap Screw x 4 (1 Bay), x 8 (2 Bays)
- Remote Control x 1
- GV-Compact DVR Quick Start Guide x 1
- GV-Compact DVR Software CD/DVD x 1
- GV-NVR Quick Start Guide x 1
- GV-NVR Software CD/DVD x 1





- **Anti-Vibration ACC Models (GV-LX8CV1 / GV-LX8CV2)**

<ul style="list-style-type: none"> <li>• 1 to 5 D-Type Video Cable x 1</li> </ul> 	<ul style="list-style-type: none"> <li>• 6 to 8 D-Type Video/ TV/ Spot Monitor Cable x 1</li> </ul> 
<ul style="list-style-type: none"> <li>• Camera Power Cable x 2</li> </ul> 	<ul style="list-style-type: none"> <li>• D-Type Audio Cable x 1</li> </ul> 
<ul style="list-style-type: none"> <li>• Power Cable x 1</li> </ul> 	<ul style="list-style-type: none"> <li>• Shorting Cable x 1</li> </ul> 
<ul style="list-style-type: none"> <li>• Lock Key x 2 (1 Bay), x 4 (2 Bays)</li> <li>• Round Screws x 6 (1 Bay), x 12 (2 Bays)</li> <li>• T-Cap Screw x 4 (1 Bay), x 8 (2 Bays)</li> <li>• Remote Control x 1</li> <li>• GV-Compact DVR Quick Start Guide x 1</li> <li>• GV- Compact DVR Software CD/DVD x 1</li> <li>• GV-NVR Quick Start Guide x 1</li> <li>• GV-NVR Software CD/DVD x 1</li> </ul>	

## 1.4 Options

Optional devices can expand your GV-Compact DVR V3's capabilities and versatility. Contact your dealer for more information.

<p><b>External IR Receiver</b></p>	<p>The external IR receiver, with a 5-meter cable (16.4 feet), allows long-distance remote control of the GV-Compact DVR V3.</p> 
<p><b>GV-GPS 232 Receiver with PS/2 Connector</b></p>	<p>GV-GPS 232 Receiver, with RS-232 interface, is a Global Position System receiver. It can be applied to vehicle tracking and location verification. The device is designed for <b>Anti-Vibration ACC models only</b>.</p> 
<p><b>2.5" to 3.5" HDD Converter</b></p>	<p>The HDD converter allows you to install a 2.5" SATA HDD into GV-Compact DVR V3.</p>
<p><b>GV-Relay V2</b></p>	<p>Working with the GV-Relay V2, GV-Compact DVR V3 can expand the voltage load up to 10A 250V AC / 10A 125V AC / 5A 100V DC.</p>
<p><b>WiFi USB Adaptor</b></p>	<p>The WiFi USB Adaptor is designed to connect the GV IP devices, such as GV-Video Servers or GV-Compact DVRs, to the wireless network. This product complies with IEEE 802.11 b/g/n (Draft 3.0) standards for wireless networking.</p>
<p><b>Power Adaptor of DC 12V, 5A</b></p>	<p>The power adaptor is used to power on the Anti-Vibration ACC model to test the connection. This device is designed for <b>Anti-Vibration ACC models only</b>.</p>

## 1.5 System Requirement

To access the Web interface of the GV-Compact DVR V3, it is required to use Microsoft Internet Explorer 7.x or later.

---

**Note:**

1. **Internet Explorer 10** is not supported in the all the firmware of GV-Compact DVR V3.
  2. If you are using **Internet Explorer 8 or later**, additional settings are required. See *Setting for Internet Explorer 8 or later* in Appendix C.
-

## Chapter 2 Physical Description

This section identifies the various components of the GV-Compact DVR V3, and provides the overview of the remote control.

### 2.1 Front Panel

#### 2.1.1 The Four-Channel Unit

- Standard Models (GV-LX4C3D1 / GV-LX4C3D2 / GV-LX4C3D2W)

##### 1. GV-LX4C3D1



Figure 2-1

##### 2. GV-LX4C3D2



Figure 2-2

### 3. GV-LX4C3D2W



Figure 2-3

No.	Name	Description
1	USB Port	The two USB ports can connect the USB storage device, Wireless LAN adaptor and/or mobile Internet device.
2	System LED	<ul style="list-style-type: none"> <li>• <b>Power LED:</b> Turns on when the power is supplied.</li> <li>• <b>Ready LED:</b> Turns on when the unit is ready for use.</li> <li>• <b>HDD LED:</b> Turns on when the HDD is reading or writing data.</li> <li>• <b>Disk Full/ Fault LED:</b> Turns on when the HDD is full or read/write error occurs.</li> </ul>
3	IR Receiver	Receives data from the infrared remote control.
4	External IR	Connects to an optional External IR Receiver.
5	Reset Button	Restarts the unit, and keeps all current configurations.
6	Default Button	Sets all configurations to their factory settings. See 8.4 <i>Restoring to Factory Default Settings</i> .
7	Storage Removal Button	Stops recording and detaches the HDD from the system.
8	HDD Activity LED	Blinks when the HDD is reading or writing data.
9	HDD Power LED	Turns on when the power is supplied.
10	Key Lock	Locks and unlocks the HDD drive bay.
11	HDD Drive Bay	Installs the SATA hard drive for recording.
12	DVD-RW Drive	Writes the DVD disc for data backup.

• **The Anti-Vibration ACC Model (GV-LX4C3V)**

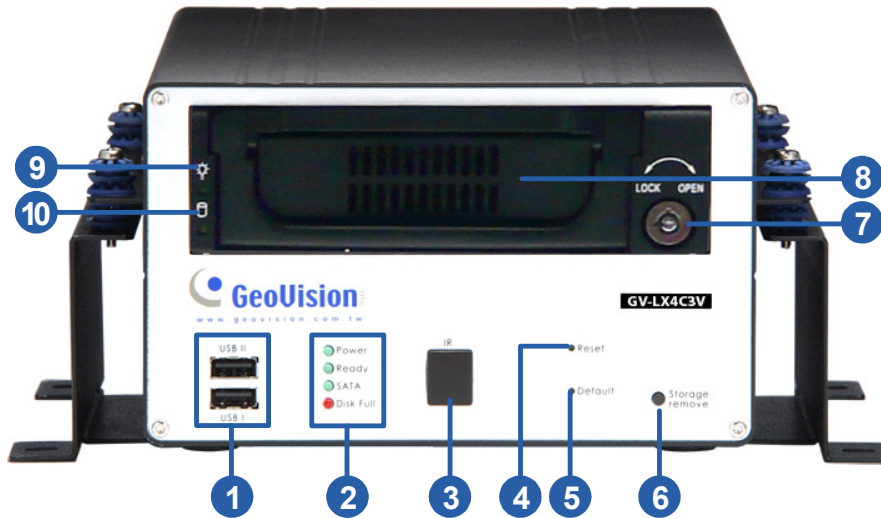

Figure 2-4

No.	Name	Description
1	USB Port	The two USB ports can connect the USB storage device, Wireless LAN adaptor and/or mobile Internet device.
2	System LED	<ul style="list-style-type: none"> <li>• <b>Power LED:</b> Turns on when the power is supplied.</li> <li>• <b>Ready LED:</b> Turns on when the unit is ready for use.</li> <li>• <b>SATA LED:</b> Turns on when the HDD is reading or writing data.</li> <li>• <b>Disk Full LED:</b> Turns on when the HDD is full or read/write error occurs.</li> </ul>
3	IR Receiver	Receives data from the infrared remote control.
4	Reset Button	Restarts the unit, and keeps all current configurations.
5	Default Button	Sets all configurations to their factory settings. See 8.4 <i>Restoring to Factory Default Settings</i> .
6	Storage Removal Button	Stops recording and detaches the HDD from the system.
7	Key Lock	Locks and unlocks the HDD drive bay.
8	HDD Drive Bay	Installs the SATA hard drive for recording.
9	HDD Power LED	Turns on when the power is supplied.
10	HDD Activity LED	Blinks when the HDD is reading or writing data.

## 2.1.2 The Eight-Channel Unit

- Standard Models (GV-LX8CD1 / GV-LX8CD2 / GV-LX8CD2W)

### 1. GV-LX8CD1

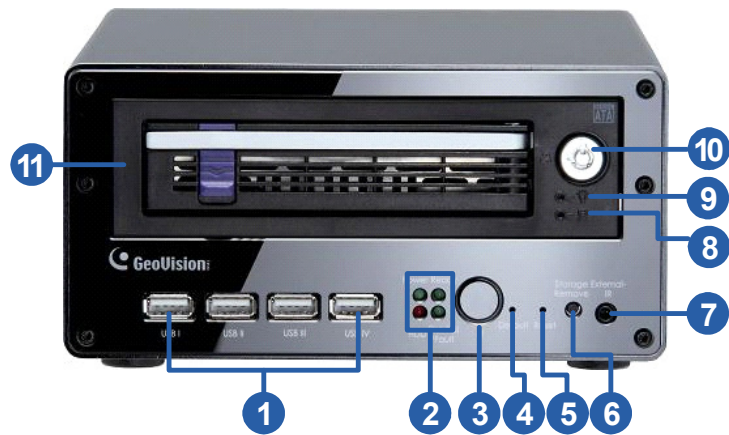

Figure 2-5

### 2. GV-LX8CD2



Figure 2-6

**GV-LX8CD2W**



Figure 2-7

No.	Name	Description
1	USB Port	The four USB ports can connect the USB storage device, Wireless LAN adaptor and/or mobile Internet device.
2	System LED	<ul style="list-style-type: none"> <li>• <b>Power LED:</b> Turns on when the power is supplied.</li> <li>• <b>Ready LED:</b> Turns on when the unit is ready for use.</li> <li>• <b>HDD LED:</b> Turns on when the HDD is reading or writing data.</li> <li>• <b>Disk Full / Fault LED:</b> Turns on when the HDD is full or read/write error occurs.</li> </ul>
3	IR Receiver	Receives data from the infrared remote control.
4	Default Button	Sets all configurations to their factory settings. See 8.4 <i>Restoring to Factory Default Settings</i> .
5	Reset Button	Restarts the unit, and keeps all current configurations.
6	Storage Removal Button	Stops recording and detaches the HDD from the system.
7	External IR	Connects to an optional External IR Receiver.
8	HDD Activity LED	Blinks when the HDD is reading or writing data.
9	HDD Power LED	Turns on when the power is supplied.
10	Key Lock	Locks and unlocks the HDD drive bay.
11	HDD Drive Bay	Installs the SATA hard drive for recording.
12	DVD-RW Drive	Writes the DVD disc for data backup.



- Anti-Vibration ACC Models (GV-LX8CV1 / GV-LX8CV2)

1. GV- GV-LX8CV1

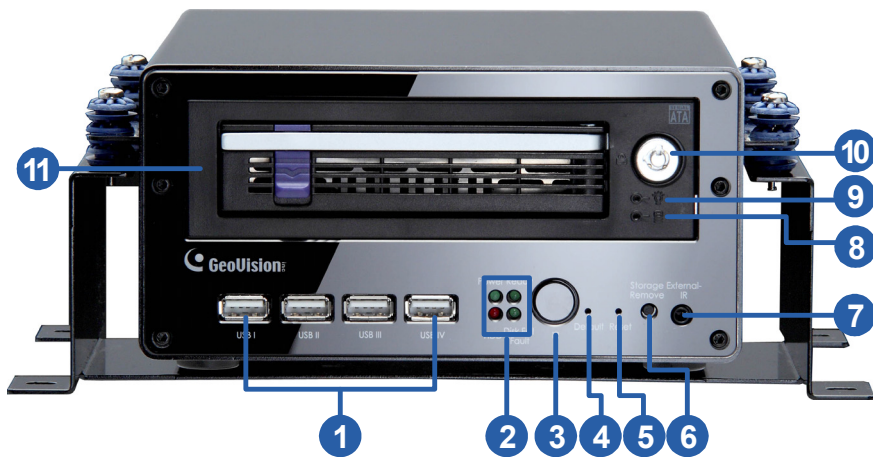

Figure 2-8

2. GV- GV-LX8CV2



Figure 2-9

## 2 Physical Description

No.	Name	Description
1	USB Port	The four USB ports can connect the USB storage device, Wireless LAN adaptor and/or mobile Internet device.
2	System LED	<ul style="list-style-type: none"><li>• <b>Power LED:</b> Turns on when the power is supplied.</li><li>• <b>Ready LED:</b> Turns on when the unit is ready for use.</li><li>• <b>HDD LED:</b> Turns on when the HDD is reading or writing data.</li><li>• <b>Disk Full / Fault LED :</b> Turns on when the HDD is full or read/write error occurs.</li></ul>
3	IR Receiver	Receives data from the infrared remote control.
4	Default Button	Sets all configurations to their factory settings. See <i>8.4 Restoring to Factory Default Settings</i> .
5	Reset Button	Restarts the unit, and keeps all current configurations.
6	Storage Removal Button	Stops recording and detaches the HDD from the system.
7	External IR	Connects to an optional External IR Receiver.
8	HDD Activity LED	Blinks when the HDD is reading or writing data.
9	HDD Power LED	Turns on when the power is supplied.
10	Key Lock	Locks and unlocks the HDD drive bay.
11	HDD Drive Bay	Installs the SATA hard drive for recording.

## 2.2 Rear Panel

### 2.2.1 The Four-Channel Unit

- Standard Models (GV-LX4C3D1 / GV-LX4C3D2 / GV-LX4C3D2W)

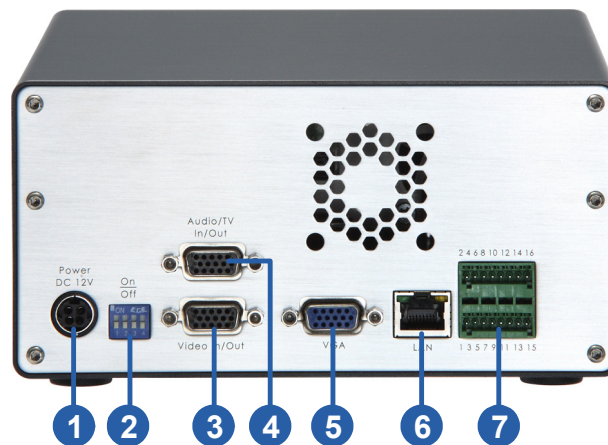

Figure 2-10

No.	Name	Description
1	DC Power Input (12V)	Connects to power supply.
2	75 Ω	When using the Loop function, turn the switches to OFF positions. The switch number is corresponding to the channel number. The default setting is ON.
3	Video In/Out	<ul style="list-style-type: none"> <li>• <b>Inputs (4 Blue Connectors/CH1-4):</b> Connects to cameras.</li> <li>• <b>Outputs (4 Black Connectors/CH1-4):</b> Loops out each camera input to monitors.</li> </ul>
4	Audio/TV In/Out	<ul style="list-style-type: none"> <li>• <b>TV Output (1 Black Connector/QUAD):</b> Connects to a TV monitor.</li> <li>• <b>Spot Monitor Output (1 Black Connector/MUX):</b> Connects to a spot monitor to display video sequentially from each video input.</li> <li>• <b>Audio Inputs (4 White Connectors/CH1-4):</b> Connects to microphones.</li> <li>• <b>Audio Output for playback (1 Red Connector/AUD-OUT):</b> Connects to speakers. Note the audio output only works during playback or when receiving callback audio.</li> </ul>
5	VGA Monitor Port	Connects to a PC monitor.
6	LAN Port	Connects to the network.
7	I/O Terminal Block	Connects to input and output devices, PTZ cameras, and etc. For details see <i>Chapter 12 The I/O Terminal Block</i> .

- The Anti-Vibration ACC Model (GV-LX4C3V)

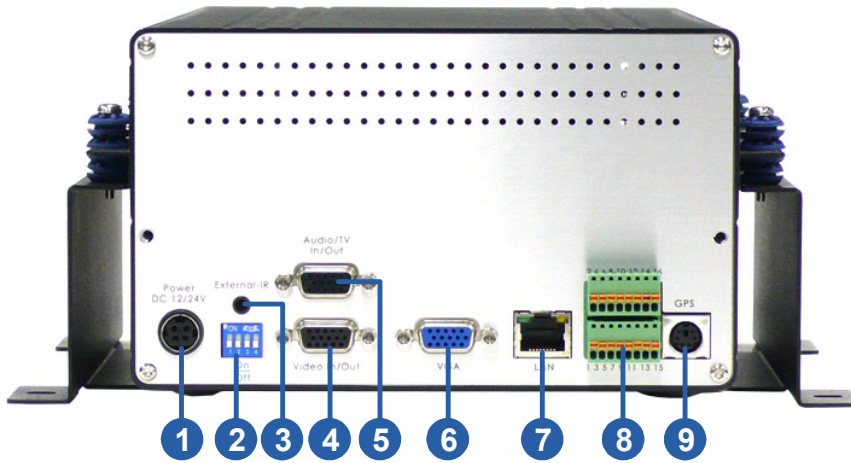

Figure 2-11

No.	Name	Description
1	DC Power Input (12V)	Connects to power supply.
2	75 Ω	When using the Loop function, turn the switches to OFF positions. The switch number is corresponding to the channel number. The default setting is ON.
3	External IR	Connects to an optional External IR Receiver.
4	Video In/Out	<ul style="list-style-type: none"> <li>• <b>Inputs (4 Blue Connectors/CH1-4):</b> Connects to cameras.</li> <li>• <b>Outputs (4 Black Connectors/CH1-4):</b> Loops out each camera input to monitors.</li> </ul>
5	Audio/TV In/Out	<ul style="list-style-type: none"> <li>• <b>TV Output (1 Black Connector/QUAD):</b> Connects to a TV monitor.</li> <li>• <b>Spot Monitor Output (1 Black Connector/MUX):</b> Connects to a spot monitor to display video sequentially from each video input.</li> <li>• <b>Audio Inputs (4 White Connectors/CH1-4):</b> Connects to microphones.</li> <li>• <b>Audio Output for playback (1 Red Connector/AUD-OUT):</b> Connects to speakers. Note the audio output only works during playback or when receiving callback audio.</li> </ul>
6	VGA Monitor Port	Connects to a PC monitor.
7	LAN Port	Connects to the network.
8	I/O Terminal Block	Connects to input and output devices, PTZ cameras and etc. For details see <i>Chapter 12 The I/O Terminal Block</i> .
9	GPS Port (PS/2 Connector)	Connects to a GPS 232 receiver.

## 2.2.2 The Eight-Channel Unit

- Standard Models (GV-LX8CD1 / GV-LX8CD2 / GV-LX8CD2W)

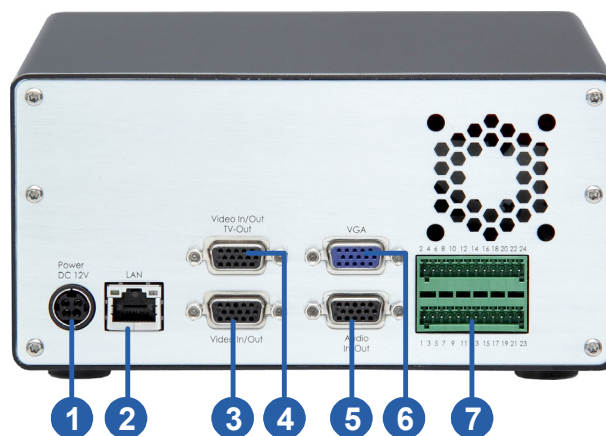

Figure 2-12

No.	Name	Description
1	DC Power Input (12V)	Connects to power supply.
2	LAN Port	Connects to the network.
3	Video In/Out	<ul style="list-style-type: none"> <li>• <b>Inputs (5 Blue Connectors/CH1-5):</b> Connects to cameras.</li> <li>• <b>Outputs (5 Black Connectors/CH1-5):</b> Loops out each camera input to monitors.</li> </ul>
4	Video In/Out & TV-Out	<ul style="list-style-type: none"> <li>• <b>Inputs (3 Blue Connectors/CH6-8):</b> Connects to cameras.</li> <li>• <b>Outputs (3 Black Connectors/CH6-8):</b> Loops out each camera input to monitors.</li> <li>• <b>TV Output (1 Black Connector/QUAD):</b> Connects to a TV monitor.</li> <li>• <b>Spot Monitor Output (1 Black Connector/MUX):</b> Connects to a spot monitor to display video sequentially from each video input.</li> </ul>
5	Audio In/Out	<ul style="list-style-type: none"> <li>• <b>Audio Inputs (8 Red Connectors/CH1-8):</b> Connects to microphones.</li> <li>• <b>Audio Output for playback (1 White Connector/AUD-OUT):</b> Connects to speakers. Note the audio output only works during playback or when receiving callback audio.</li> </ul>
6	VGA Monitor Port	Connects to a PC monitor.
7	I/O Terminal Block	Connects to input and output devices, PTZ cameras and etc. For details see <i>Chapter 12 The I/O Terminal Block</i> .

- **Anti-Vibration ACC Models (GV-LX8CV1 / GV-LX8CV2)**

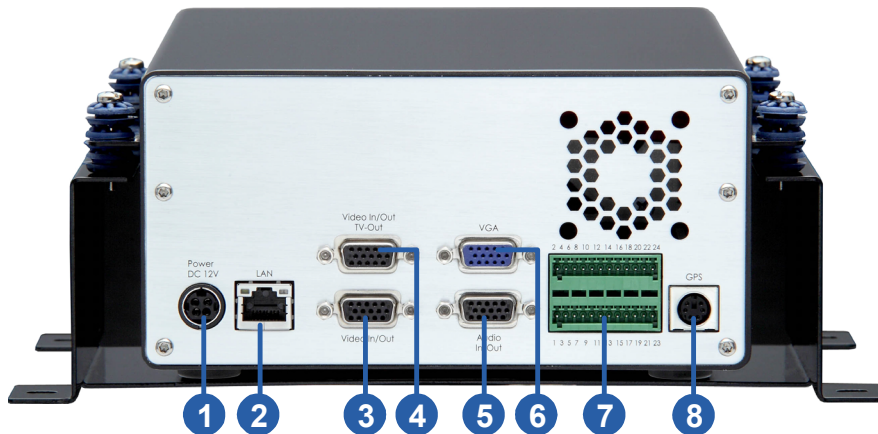

Figure 2-13

No.	Name	Description
1	DC Power Input (12V)	Connects to power supply.
2	LAN Port	Connects to the network.
3	Video In/Out	<ul style="list-style-type: none"> <li>• <b>Inputs (5 Blue Connectors/CH1-5):</b> Connects to cameras.</li> <li>• <b>Outputs (5 Black Connectors/CH1-5):</b> Loops out each camera input to monitors.</li> </ul>
4	Video In/Out TV-Out	<ul style="list-style-type: none"> <li>• <b>Inputs (3 Blue Connectors/CH6-8):</b> Connects to cameras.</li> <li>• <b>Outputs (3 Black Connectors/CH6-8):</b> Loops out each camera input to monitors.</li> <li>• <b>TV Output (1 Black Connector/QUAD):</b> Connects to a TV monitor.</li> <li>• <b>Spot Monitor Output (1 Black Connector/MUX):</b> Connects to a spot monitor to display video sequentially from each video input.</li> </ul>
5	Audio In/Out	<ul style="list-style-type: none"> <li>• <b>Audio Inputs (8 Red Connectors/CH1-8):</b> Connects to the microphone.</li> <li>• <b>Audio Output for playback (1 White Connector/AUD-OUT):</b> Connects to speakers. Note the audio output only works during playback or when receiving callback audio.</li> </ul>
6	VGA Monitor Port	Connects to a PC monitor.
7	I/O Terminal Block	Connects to input and output devices, PTZ cameras and etc. For details see <i>Chapter 12 The I/O Terminal Block</i> .
8	GPS Port (PS/2 Connector)	Connects to a GPS 232 receiver.



## 2.3 Remote Control









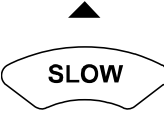
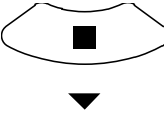
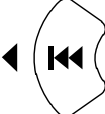



The GV-Compact DVR V3 Remote Control is provided to configure and operate the GV-Compact DVR V3.

### 2.3.1 The Four-Channel Unit



Figure 2-14

Button	Description
	Stops recording.
	Starts recording.
	<b>OSD menu:</b> Moves the focus upward to the desired item. <b>Playback:</b> Decreases the speed of playback.
	<b>OSD menu:</b> Moves the focus downward to the desired item. <b>Playback:</b> Stops playback.
	<b>OSD menu:</b> Moves the focus leftward to the desired item; moves to the previous page. <b>Playback:</b> Plays the video backward at different speeds (2x, 4x, 8x, 16x and 32x).





Button	Description
	<p><b>OSD menu:</b> Moves the focus rightward to the desired item; moves to the next page.</p> <p><b>Playback:</b> Plays the video forward at different speeds (2x, 4x, 8x, 16x and 32x).</p>
	<p><b>OSD menu:</b> Enters the menu option and confirms the selection.</p> <p><b>Playback:</b> Plays or pauses video.</p>
	<p>Switches to Channel 1 or I/O device 1.</p>
	<p>Switches to Channel 2 or I/O device 2.</p>
	<p>Switches to Channel 3 or I/O device 3.</p>
	<p>Switches to Channel 4 or I/O device 4.</p>
<p>QUAD</p> 	<p>Switches to the screen of 4 divisions.</p>
<p>ZOOM</p> 	<p>Zooms in or out.</p>
<p>SEARCH</p> 	<p>Calls up the menu of SEARCH/PLAYBACK.</p>
	<p>Confirms the menu selection.</p>
<p>ENTER MENU</p> 	<p>Calls up the main menu.</p>
 <p>CANCEL</p>	<p>Quits the menu selection or exits the menu.</p>
<p><b>A / B / C</b> <b>Device Type</b></p>	<p>Switches among up to 3 units of GV-Compact DVR V3 for remote control. To set the device type of the GV-Compact DVR V3, see <i>IR TYPE, 4.8.4 Display Settings</i>.</p>







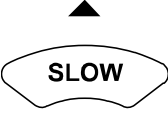
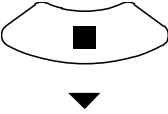
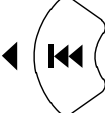



## 2.3.2 The Eight-Channel Unit



Figure 2-15

Button	Description
	Stops recording.
	Starts recording.
	<b>OSD menu:</b> Moves the focus upward to the desired item. <b>Playback:</b> Decreases the speed of playback.
	<b>OSD menu:</b> Moves the focus downward to the desired item. <b>Playback:</b> Stops playback.
	<b>OSD menu:</b> Moves the focus leftward to the desired item; moves to the previous page. <b>Playback:</b> Plays the video backward at different speeds (2x, 4x, 8x, 16x and 32x).
	<b>OSD menu:</b> Moves the focus rightward to the desired item; moves to the next page. <b>Playback:</b> Plays the video forward at different speeds (2x, 4x, 8x, 16x and 32x).

## 2 Physical Description

Button	Description
	<b>OSD menu:</b> Enters the menu option and confirms the selection. <b>Playback:</b> Plays or pauses video.
	Switches to Channel 1 to Channel 8 or I/O device 1 to 8.
	Switches to the screen of 4 divisions.
	Zooms in or out.
	Calls up the menu of SEARCH/PLAYBACK.
	Confirms the menu selection.
	Calls up the main menu.
	Quits the menu selection or exits the menu.
<b>A / B / C Device Type</b>	Switches among up to 3 units of GV-Compact DVR V3 for remote control. To set the device type of the GV-Compact DVR V3, see <i>IR TYPE, 4.8.4 Display Settings</i> .

## Chapter 3 Getting Started

Getting started with the GV-Compact DVR V3 consists of the following steps:

### **3.1 Basic Connection for Standard Models**

Install the video display devices.

### **3.2 Basic Connection for Anti-Vibration Models**

Connect the unit to the vehicle.

### **3.3 Connecting Anti-Vibration ACC Models**

Describe the ACC connection in detail.

### **3.4 Connecting Optional Video Output Devices**

Connect optional video output devices.

### **3.5 Installing a Hard Drive**

Install a hard drive for video recording.

### **3.6 Turning on and off the Power**

Turn on and off the unit.

### **3.7 Formatting Hard Drive**

Format the hard drive before recording.

### **3.8 Main Screen Overview**

Access the system information on the main screen.

### **3.9 Basic Operation**

### 3.1 Basic Connection for Standard Models

The following instructions describe the basic connection to the GV-Compact DVR V3.

#### 3.1.1 The Four-Channel Unit



Figure 3-1

1. Use the supplied power adaptor to connect to power.
2. Connect to cameras by using the blue connectors of the supplied D-Type Video Cable.
3. Connect to microphones and a speaker by using the supplied D-Type Audio/TV/Spot Monitor Cable. Connect microphones to the four white connectors of the cable, and a speaker to the red connector.
4. Connect video output. There are two options:
  - Using the black connector (QUAD) of the supplied D-Type Audio/TV/Spot Monitor Cable, connect to a **TV monitor**.
  - Using the VGA cable supplied by the monitor manufacturer, connect to a **VGA monitor** (as illustrated in the figure).
5. Use the standard RJ-45 cable to connect the unit to the network.

---

#### Note:

1. To set the video resolution on the VGA monitor, see *VGA SETTINGS, 4.8.4 Display Settings*.
  2. The GV-Compact DVR V3 cannot work with the microphone that acquires power from the unit. Use the microphone that has external power supply.
-

### 3.1.2 The Eight-Channel Unit

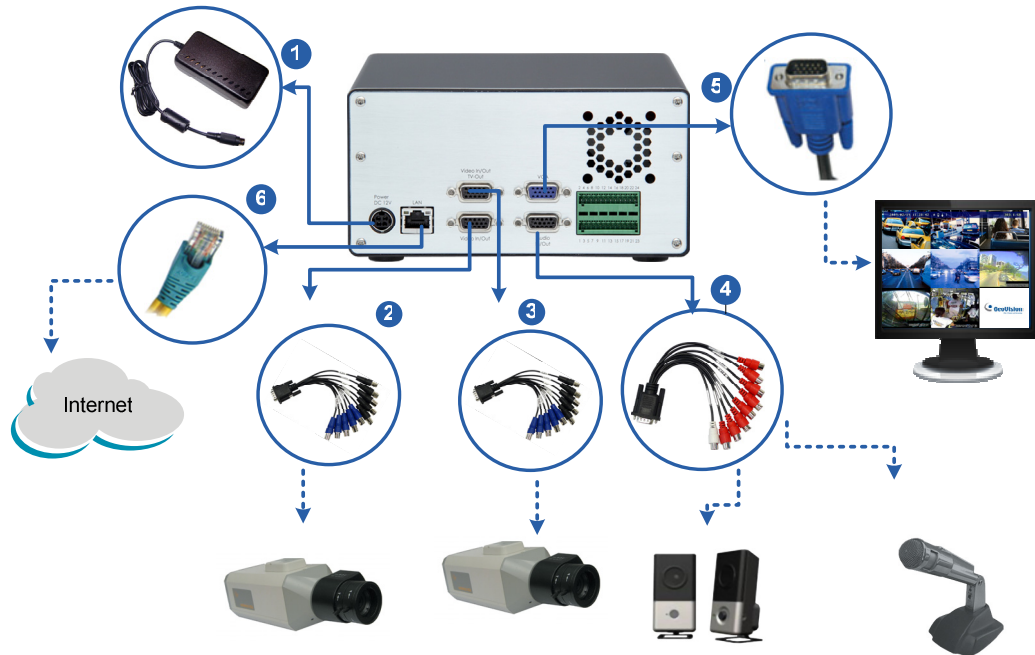

Figure 3-2

1. Use the supplied power adaptor to connect to power.
2. Connect to cameras (Camera 1 to 5) by using the blue connectors of the supplied 1 to 5 D-Type Video Cable.
3. Connect to cameras (Camera 6 to 8) by using the blue connectors of the supplied 6 to 8 D-Type Video/ TV/Spot Monitor Cable.
4. Connect to microphones and a speaker by using the supplied D-Type Audio Cable. Connect microphones to the eight red connectors of the cable, and a speaker to the white connector.
5. Connect video output. There are two options:
  - Using the black connector (QUAD) of the supplied 6 to 8 D-Type Video/TV/Spot Monitor Cable, connect to a **TV monitor**.
  - Using the VGA cable supplied by the monitor manufacturer, connect to a **VGA monitor** (as illustrated in the figure).
6. Use the standard RJ-45 cable to connect the unit to the network.

---

**Note:**

1. To set the video resolution on the VGA monitor, see [VGA SETTINGS, 4.8.4 Display Settings](#).
  2. The GV-Compact DVR V3 cannot work with the microphone that acquires power from the unit. Use the microphone that has external power supply.
-

## 3.2 Basic Connection for Anti-Vibration Models

You need to connect the Anti-Vibration ACC model to ACC wire and power wire on the vehicle. When the unit is connected to the ACC wire properly, it will automatically start after you power on the vehicle for 5 seconds. After you power off the vehicle for 30 seconds, the unit will turn off automatically. During the 30 seconds after power off, the GV-Compact DVR V3 will stop recording and the hard drive will be removed from the system automatically.

---

**Note:** You could extend the power-off delay time from 0 to 30 minutes, refer to 6.8.7. *ACC Settings*.

---

### 3.2.1 The Four-Channel Unit

1. Connect the ACC wire from the vehicle to **Pin 16** on the terminal Block. For details, see *Connecting the ACC Wire* of 3.3.2 *Connecting to a Vehicle*.
2. Connect the Power Cable to the GV-Compact DVR V3 and to the vehicle. For details, see *Connecting the Power Wire* of 3.3.2 *Connecting to a Vehicle*.
3. Connect the **black** wire of the Camera Power Cable to **Pin 10** on the terminal block, and **red** wire to **Pin 11** on the terminal Block.
4. Connect the Camera Power Cable to up to four cameras.

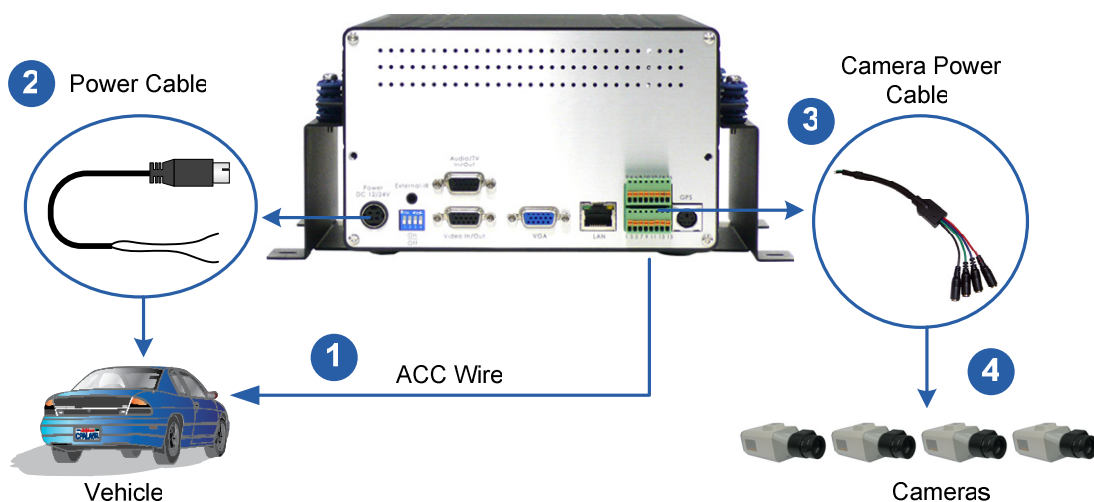

Figure 3-3

### 3.2.2 The Eight-Channel Unit

1. Connect the ACC wire from the vehicle to **Pin 24** on the terminal block. For details, see *Connecting the ACC Wire* of 3.3.2 *Connecting to a Vehicle*.
2. Connect the Power Cable to the GV-Compact DVR V3 and to the vehicle. For details, see *Connecting the Power Wire* of 3.3.2 *Connecting to a Vehicle*.
3. Connect the **black** wires of the Camera Power Cables to **Pin 18** and **Pin 20** on the terminal block; connect the **red** wires of the Camera Power Cables to **Pin 17** and **Pin 19** on the terminal block.
4. Connect the Camera Power Cables to up to eight cameras.

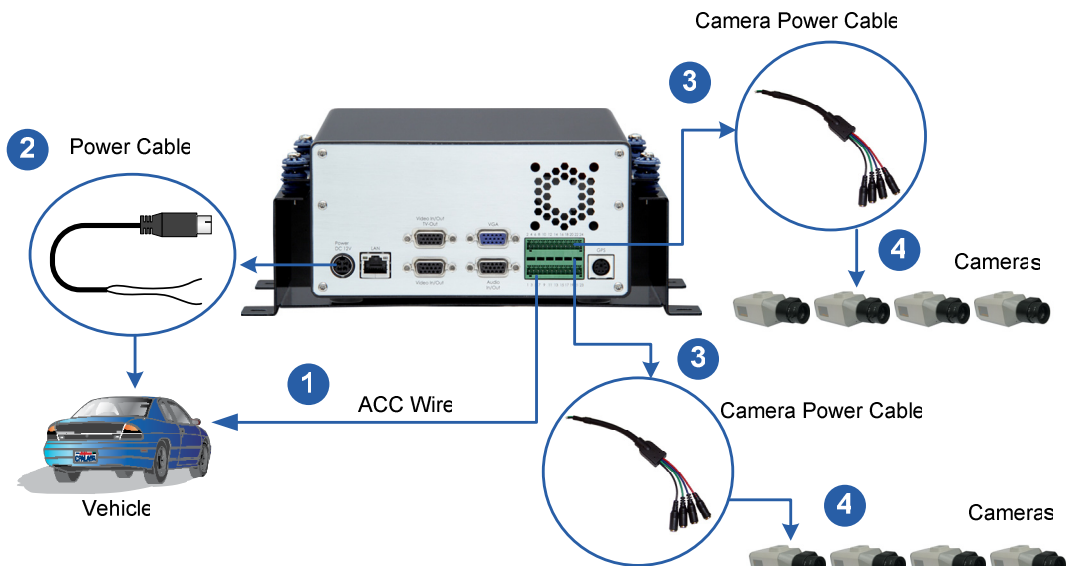

Figure 3-4

### 3.3 Connecting Anti-Vibration ACC Models

You need to connect the Anti-Vibration ACC model to the ACC wire and power wire on the vehicle. Before real deployment, it is suggested to test connection to the ACC wire and set up the unit.

#### 3.3.1 Connecting and Testing

Before you connect the Anti-Vibration ACC model to a vehicle, it is recommended to test and set up the unit first by using the supplied **Shorting Cable**. The Shorting Cable is designed to simulate the ACC wiring between the unit and the vehicle. For the test, you need to prepare a power adaptor (DC 12V, 5.0A) to power on the unit. Follow the steps below.

**Items required for testing:**

- Supplied Shorting Cable
- Power Adaptor of DC 12V, 5A (which can be purchased from GeoVision)



1. Connect the Shorting Cable to **Pins 14 and 16** (4-channel unit) or **Pins 22 and 24** (8-channel unit) on the terminal block.

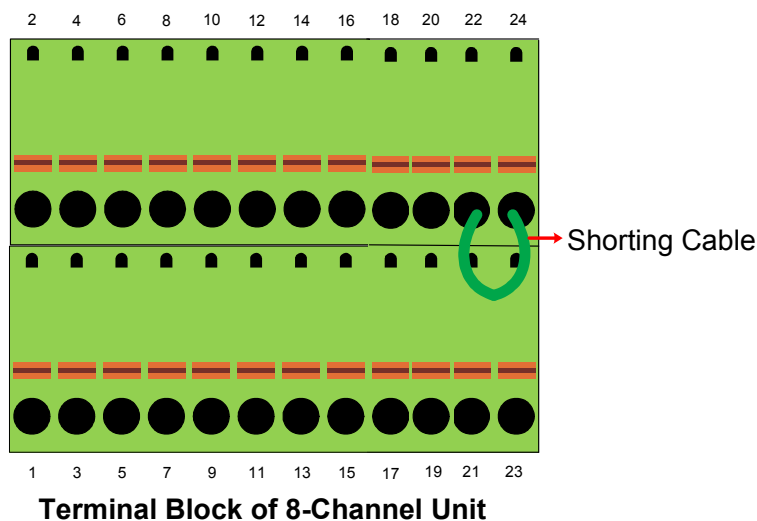
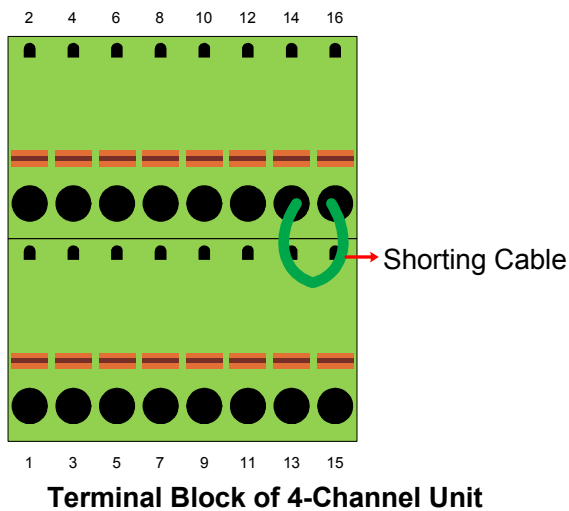

*Figure 3-5*

2. Power on the unit by using a power adaptor. The unit automatically starts after powering up for 5 seconds.
3. Set up the settings of the GV-Compact DVR V3, such as storage, images, recording and etc through its OSD or Web interface. See *3.7 Formatting Hard Drive* and *3.8 Basic Operation*.
4. Remove the power adaptor. The unit turns off immediately after powering off.

### 3.3.2 Connecting to a vehicle

---

**IMPORTANT:**

Below is an example of how to connect the Anti-Vibration ACC model to the vehicle. Since each vehicle differs in design, refer to the owner's manual of your vehicle for details and carefully follow the safety measures. If you are unsure about how to carry out the instructions, have the installation done by a properly trained technician.

---

#### Connecting the ACC Wire

1. Locate the fuse box. The fuse box is usually located below the dashboard and to the left of the steering wheel. You may need to refer to the owner's manual of your vehicle.

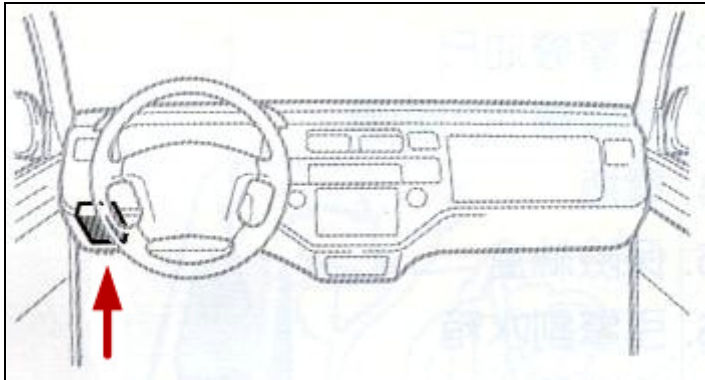

Figure 3-6

2. Open the cover of the fuse box.

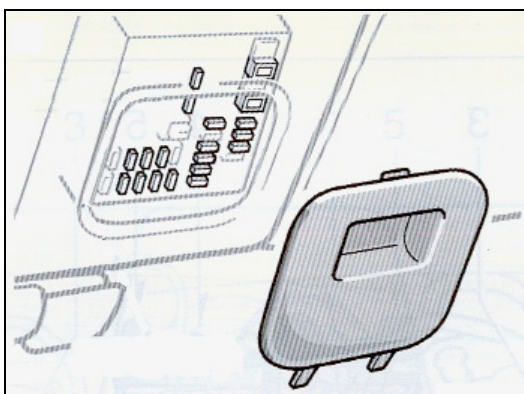

Figure 3-7



### Connecting the Power Wire

The supplied power cable of the Anti-Vibration ACC model splits into two wires. Connect the white wire to the vehicle's power cable and use the black wire to make the ground connection.

---

**Note:** The Compact DVR V3 supports the power input of 10V to 28V, 5A.

---

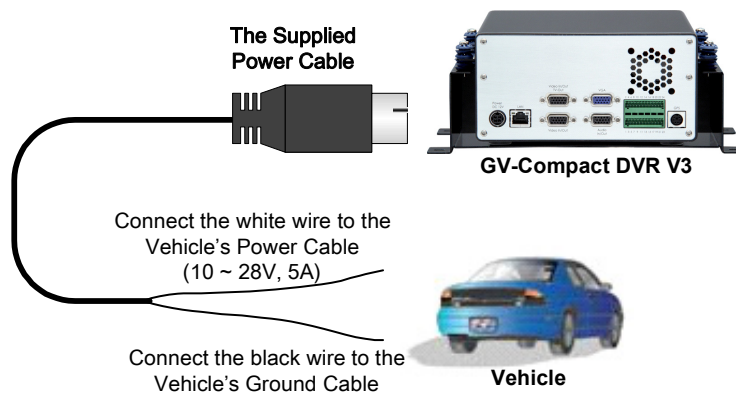

*Figure 3-10*

1. Using the fuse specification diagram, locate the power cable connecting to the fuse box. Connect the **white power** wire of the GV-Compact DVR V3 to the **positive-voltage** power cable. You may need to use a voltmeter to determine which one is the positive voltage.

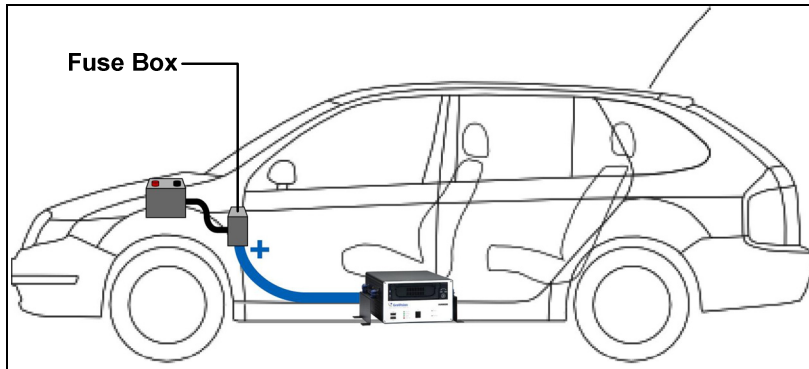

Figure 3-11

2. Remove the car door scuff plate and wire the power cable along the driver's door toward the back seat.

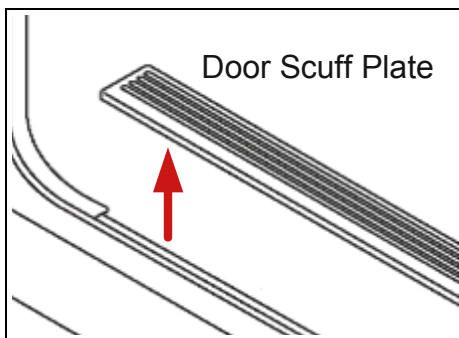

Figure 3-12

3. Use one of the two methods below to connect the **black ground** wire of the GV-Compact DVR V3.
  - **Method 1:** Connect the black ground wire to the negative-voltage power cable from the fuse box.

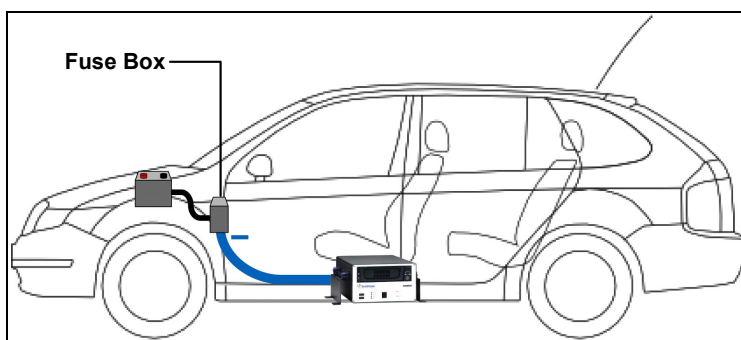
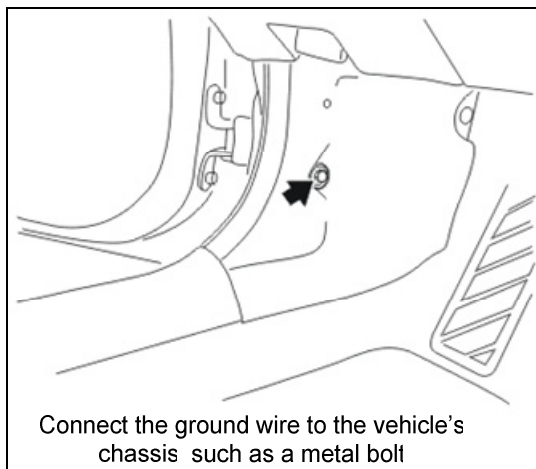

Figure 3-13

- **Method 2:** Connect the black ground wire to the vehicle's chassis so that the wire contacts the bare metal, for example, a metal bolt nearby.



*Figure 3-14*

Depending on the make and model of your vehicle, sometimes only one method will work. When the black ground wire is connected correctly, GV-Compact DVR V3 will automatically shut down 30 seconds after the car's power is off. If GV-Compact DVR V3 does not shut down 30 seconds after the car ignition is off, try to connect the black ground wire using the other method.

4. Turn on the car ignition and the GV-Compact DVR V3 should start automatically within 5 seconds. Turn off the car ignition and the GV-Compact DVR V3 should shut down 30 seconds after the car ignition is off.

### 3.4 Connecting Optional Video Output Devices

#### 3.4.1 The Four-Channel Unit

The four-channel GV-Compact DVR V3 offers the looping video output for 4 monitors. It also offers the spot monitor output to display video sequentially from each video input.

For the settings of the spot monitor, see 4.8.5 *Spot Monitor Settings*.

---

**Note:** To loop out videos, turn the 75  $\Omega$  switches to OFF positions. See No. 2, Figure 2-10 / 2-11. The switch number is corresponding to the channel number.

---

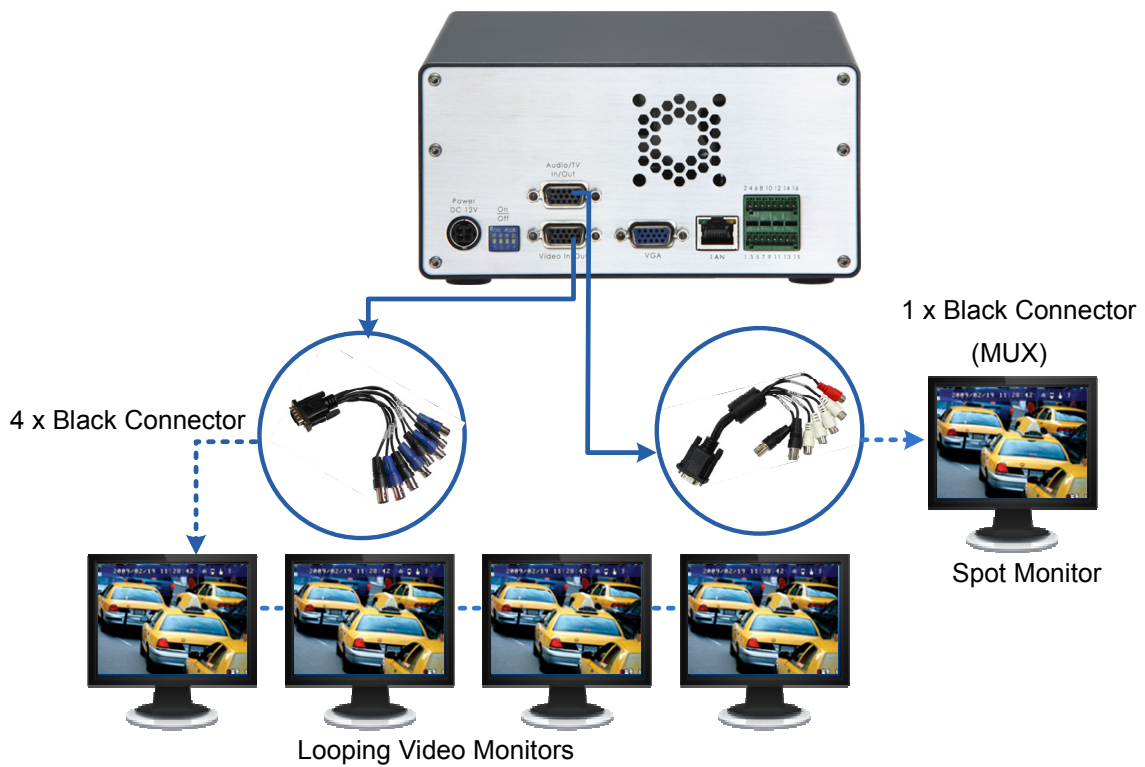

Figure 3-15

### 3.4.2 The Eight-Channel Unit

The eight-channel GV-Compact DVR V3 offers the looping video output for 8 monitors. It also offers the spot monitor output to display video sequentially from each video input.

For the settings of the spot monitor, see 4.8.5 *Spot Monitor Settings*.

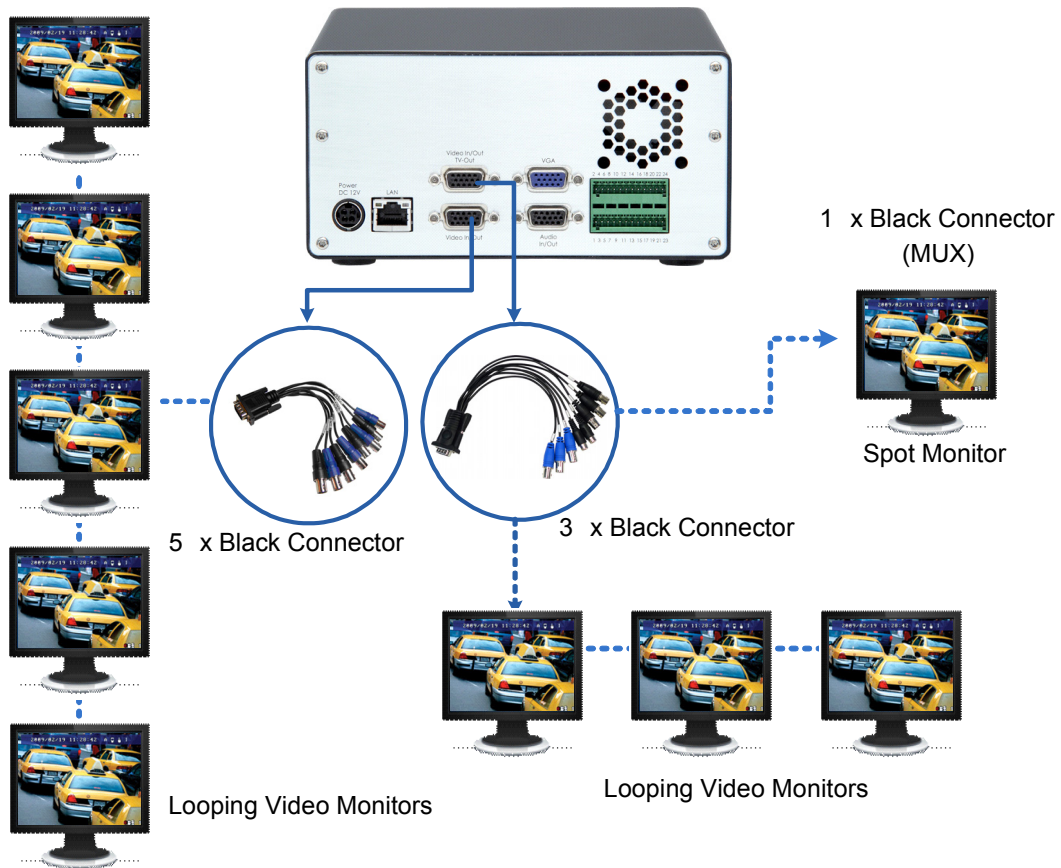

Figure 3-16



## 3.5 Installing a Hard Drive

The GV-Compact DVR V3 comes equipped with one or two 3.5" SATA hard drive bay(s) for video recording. Follow these steps to install the hard drive.

---

### IMPORTANT:

The GV-Compact DVR V3 does not support hot swap. Ensure to power off the unit before removing the hard drive. Also ensure to remove the hard drive only after power was shut off for more than 60 seconds. This would protect and extend the operating life of the hard drive.

For the Anti-vibration ACC models (GV-LX4C3V, GV-LX8CV1 and GV-LX8CV2), it is necessary to use the hard drive especially for notebook, vehicle or surveillance applications, and tightly fasten the unit on the vehicle to prevent vibration and shock hazard.

---

### 3.5.1 The Four-Channel Unit

- **Standard Models (GV-LX4C3D1 / GV-LX4C3D2 / GV-LX4C3D2W)**

1. Make sure the unit is powered off.
2. Push down the blue button to loose the latch of the hard drive drawer, and pull out the drawer.



Figure 3-17

3. Unscrew and remove the extender of the drawer.

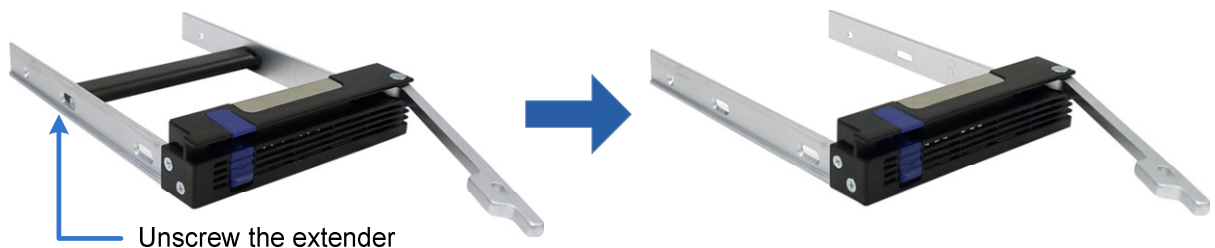
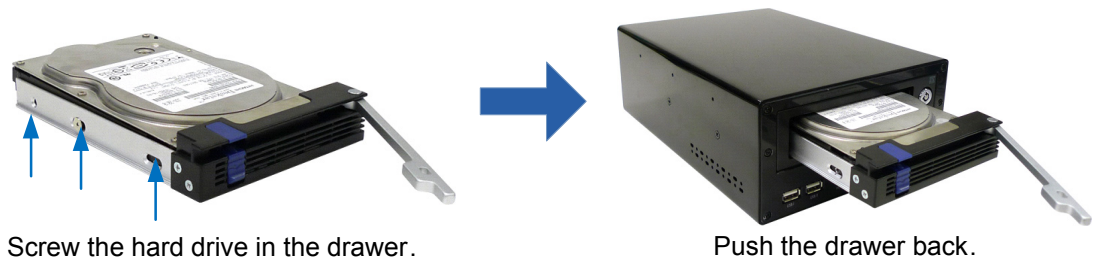

Figure 3-18

4. Insert the hard drive in the drawer, secure the hard drive with 6 supplied T-Cap screws, and push the drawer back in the drive bay of the unit.



*Figure 3-19*

5. To install a **2.5" SATA hard drive**, you need a HDD Converter from GeoVision to enclose the 2.5" hard drive. Insert the Converter installed with a 2.5" hard drive into the pull-out drive drawer, secure the Converter with 6 supplied T-Cap screws, and push the drive drawer back in the drive bay.



*Figure 3-20*

6. Lock the drive bay with the supplied key.

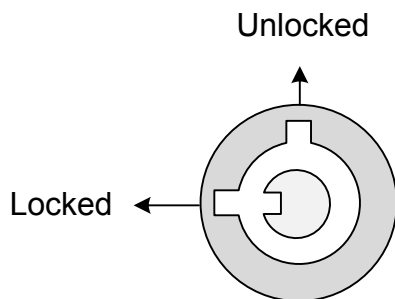

*Figure 3-21*

- **Anti-Vibration ACC Model (GV-LX4C3V)**

1. Make sure the unit is powered off.
2. Pull out the drive drawer, insert the hard drive in the drawer, secure the hard drive with 4 supplied T-Cap screws, and push the drawer back in the drive bay of the unit.



*Figure 3-22*

3. To install a **2.5" SATA hard drive**, you need a HDD Converter from GeoVision to enclose the 2.5" hard drive. Insert the Converter installed with a 2.5" hard drive into the pull-out drive drawer, secure the Converter with 4 supplied screws, and push the drive drawer back in the drive bay.



*Figure 3-23*

4. Lock the drive bay with the supplied key.

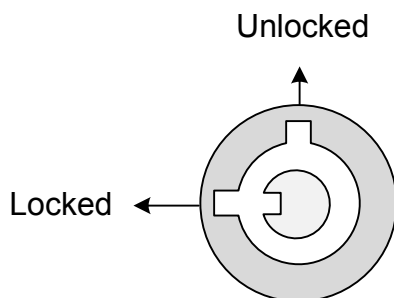

*Figure 3-24*

### 3.5.2 The Eight-Channel Unit

1. Make sure the unit is powered off.
2. Push down the blue button to loose the latch of the hard drive drawer, and pull out the drawer.



*Figure 3-25*

3. Unscrew and remove the extender of the drawer.

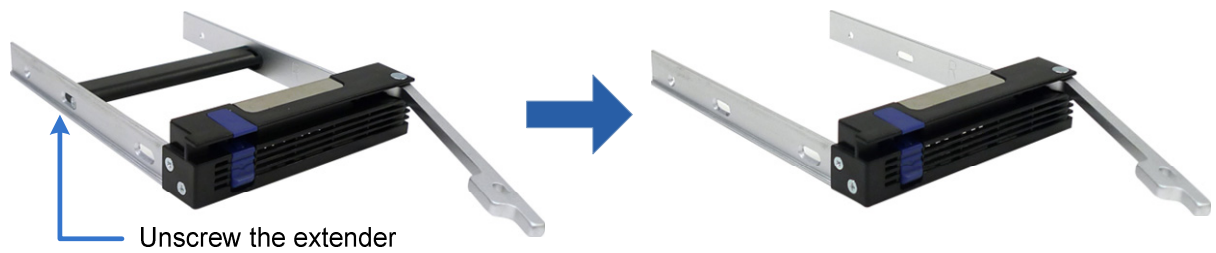

*Figure 3-26*

4. Insert the hard drive in the drawer, secure the hard drive with 6 supplied T-Cap screws, and push the drawer back in the drive bay of the unit.

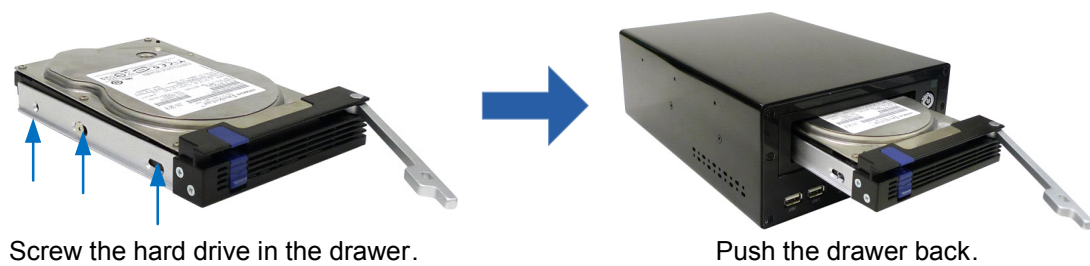

*Figure 3-27*

5. To install a **2.5" SATA hard drive**, you need a HDD Converter from GeoVision to enclose the 2.5" hard drive. Insert the Converter installed with a 2.5" hard drive into the pull-out drive drawer, secure the Converter with 6 supplied T-Cap screws, and push the drive drawer back in the drive bay.



*Figure 3-28*

6. Lock the drive bay with the supplied key.

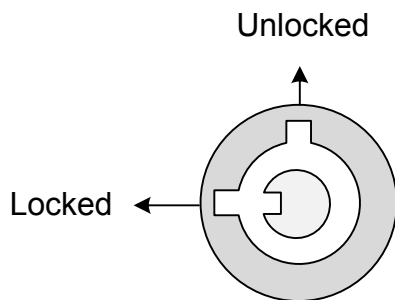

*Figure 3-29*

### 3.6 Turning On / Off the Power

### 3.6.1 Turning On the Power

1. Connect the GV-Compact DVR V3 to the power, and the **Power LED** should turn on. If a HDD is installed on the GV-Compact DVR V3, the **HDD Power LED** should turn on as well.
2. The system starts initializing for several seconds. After this, the **Ready LED** will turn to green and the main screen will be displayed.

If the GV-Compact DVR V3 is connected to the ACC wire of the vehicle, the unit will automatically start after you power on the vehicle for 5 seconds. Power is supplied to the unit as long as the vehicle ignition is on.

### 3.6.2 Turning Off the Power

Before unplugging the power cable, ensure both the **HDD LED** and **HDD Activity LED** turn off; otherwise, the recorded video may be lost.

If the GV-Compact DVR V3 is installed in a vehicle, the unit will automatically turn off after you power off the vehicle for 30 seconds. During the 30 seconds, the GV-Compact DVR V3 will stop recording and the hard drive will be removed from the system automatically.

---

**Note:** You could extend the power-off delay time from 0 to 30 minutes, refer to [6.8.7. ACC Settings](#).

---



## 3.7 Formatting Hard Drive

The GV-Compact DVR V3 is a Linux-based system. You must follow the steps below to format the hard drive before recording.

1. Press the **Menu** button on the Remote Control to enter the main menu.
2. Select **ADVANCED**, select **STORAGE SETTINGS**, and then select **STORAGE MANAGEMENT**. The model name of the connected hard drive appears.



Figure 3-30

3. Move the focus to **DETAIL**, select **FORMAT** and press the  button. You will be prompted to confirm the action.
4. Select **YES** and press the  button to start formatting. The format progress will appear in the top right of the screen, e.g. "PART 1: 94/100". When the format is complete, the amount of free disk space will be displayed.

---

### Note:

1. The storage device will be divided into three partitions after being formatted. Each partition has a maximum capacity of 200 GB.
  2. The connected USB mass storage device must also be formatted according to above instructions before use.
-

### 3.8 Main Screen Overview

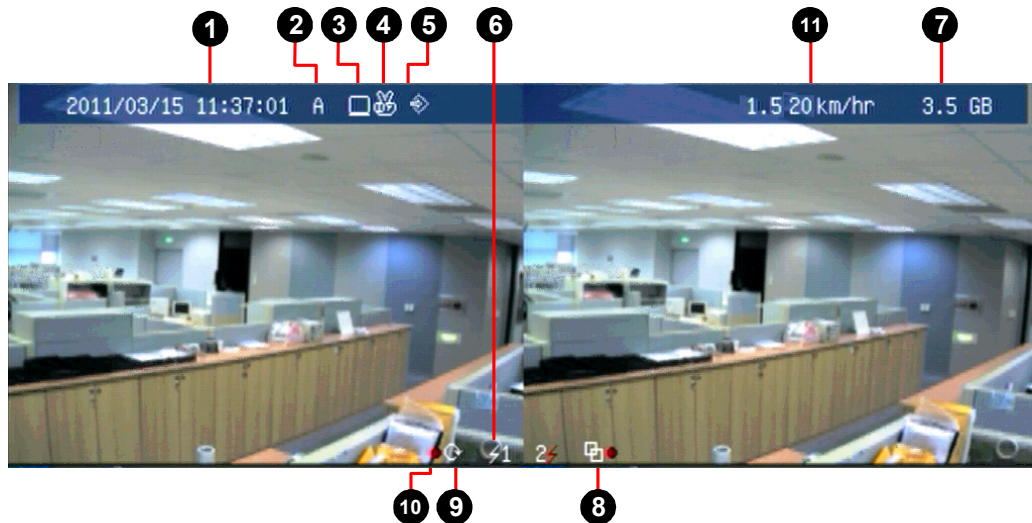









Figure 3-31

1. **Date and time:** Indicates the current date and time when viewing live video.
2. **A / B / C:** Indicates the type of device defined for the GV-Compact DVR V3.
3. **Monitoring icon** : Appears when the monitoring is activated.
4. **Manual recording icon**  or **Schedule recording icon** : Appears when the recording is started manually or by schedule.
5. **Input icon** : Appears when the input device is installed and activated.
6. **Channel number/Camera name:** Displays the camera number or name.
7. **Hard disk status:** Indicates the amount of free space on the hard disk. When the disk is full, the status will turn to red.
8. **Motion detection mode icon** : Appears when the camera is set to the recording mode of motion detection.
9. **Round-the-clock mode icon** : Appears when the camera is set to the recording mode of round-the-clock.
10. **Recording icon** : Appears when the monitoring is started. A red icon indicates the image of the camera is being recorded.
11. **Vehicle speed:** Indicates the average speed of the vehicle when the GPS function is enabled. This function is only available for the Anti-Vibration ACC models (GV-LX4C3V, GV-LX8CV1 and GV-LX8CV2).



## 3.9 Basic Operation

This section describes the basic operation of the GV-Compact DVR V3.

### 3.9.1 Date/Time Adjustment

It is recommended that you enter the current date and time before start recording so that the correct date and time is associated with all videos.

- To adjust the date and time, press the **Menu** button on the Remote Control, select **ADVANCED** and then select **DATE AND TIME**. For details, see *4.8.1 Date and Time*.

### 3.9.2 Recording Operation

Before start recording, configure the recording settings properly according to your needs.

- To start recording, press the **REC** button on the Remote Control to record video onto the hard drive with the corresponding programmed recording settings. The RED recording icon  will appear on the corresponding camera screen. The **HDD Power LED** and **HDD Activity LED** lights will be blinking, indicating the GV-Compact DVR V3 is in recording mode.
- To stop recording, press the **Stop** button on the Remote Control at any time.

To	Steps
Set the recording mode	Press the <b>Menu</b> button and select <b>MONITORING SETTINGS</b> .
Activate the audio recording	<ol style="list-style-type: none"> <li>Press the <b>Menu</b> button, select <b>CHANNEL SETTINGS</b>, press one <b>Channel</b> button (Ch1 - CH4 for the four-channel unit; CH1 - CH8 for the eight-channel unit), and select <b>VIDEO/AUDIO SETTINGS</b>.</li> <li>Select <b>AUDIO RECORDING</b>, change OFF to <b>ON</b>.</li> </ol>
Set the recording schedule	<ol style="list-style-type: none"> <li>Press the <b>Menu</b> button, select <b>RECORDING SCHEDULE</b>, and select one of scheduling methods. See <i>4.5 Recording Schedule</i>.</li> <li>To start scheduled recording, press the <b>Menu</b> button, select <b>MONITORING SETTINGS</b>, change MONITORING MODE to <b>SCHEDULE</b>, and then select <b>START</b>.</li> </ol>
Set the pre-recording and post-recording	Press the <b>Menu</b> button, select <b>CHANNEL SETTINGS</b> , press one <b>Channel</b> button (Ch1 - CH4 for the four-channel unit; CH1 - CH8 for the eight-channel unit), and select <b>ALARM SETTINGS</b> .

### 3.9.3 Search/Playback Operation

To access the recorded video for playback, press the **Search** button to have several search and playback options. For details, see *4.6 Search / Playback*.

### 3.9.4 PTZ Operation

To install the PTZ camera, press the **Menu** button on the Remote Control, select **CHANNEL SETTINGS**, press one **Channel** button (Ch1 - CH4 for the four-channel unit; CH1 - CH8 for the eight-channel unit), and then select **PTZ Settings**. For details, see *4.1.7 PTZ Settings*.

To control the PTZ movement, press the **Channel** button to display the PTZ channel, and use directional buttons to control the PTZ.

### 3.9.5 Channel Number and Camera Name

To display the channel number or camera title, see *4.8.4 Display Settings*. To change the camera name, see *4.1.1 Channel Name*.

### 3.9.6 Video Backup

To back up data and video on a DVD disc or USB storage device, see *4.8.9 Backup*.

## Chapter 4 OSD Menu Configurations

The GV-Compact DVR V3 is configured through a series of menus on screen by using the Remote Control. This section describes the functions and options in the on-screen display (OSD) menus. To enter the main menu, press the **Menu** button on the Remote Control. Eight submenus will appear as shown below.

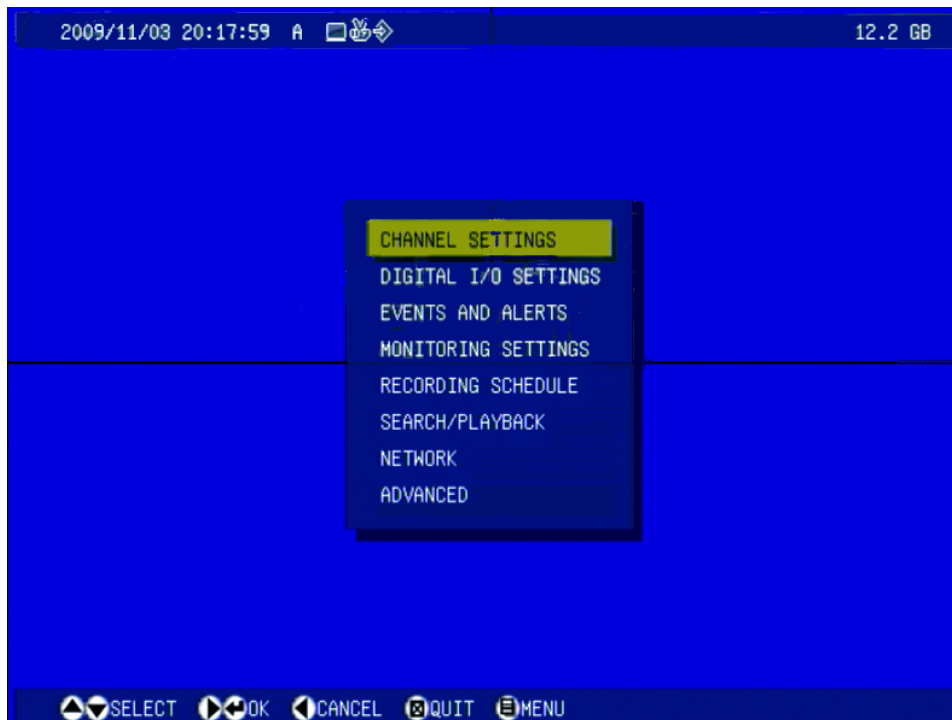

Figure 4-1

---

**Note:** A few of functions are only available in Web-based configurations. For the functions of IP filtering, Visual Automation and Backup Center, see *Chapter 6 Remote Configurations*.

---

**List of Main Menu Options**

Find the topic of interest by referring to the section number prefixed to each option.

4.1 CHANNEL SETTINGS	4.1.1 CHANNEL NAME
	4.1.2 VIDEO/AUDIO SETTINGS
	4.1.3 MOTION DETECTION
	4.1.4 MOTION TRIGGER OUTPUT SETTINGS
	4.1.5 ALARM SETTINGS
	4.1.6 CAMERA SETTINGS
	4.1.7 PTZ SETTINGS
	4.1.8 PTZ CONTROL
	4.1.9 PRIVACY MASK
4.2 DIGITAL I/O SETTINGS	4.2.1 DIGITAL INPUT SETTINGS
	4.2.2 DIGITAL OUTPUT SETTINGS
	4.2.3 GPS SETTINGS
4.3 EVENTS AND ALERTS	4.3.1 E-MAIL
	4.3.2 FTP
	4.3.3 CENTER V2
	4.3.4 VSM
	4.3.5 GV-GIS
	4.3.6 VIDEO GATEWAY / RECORDING SERVER
	4.3.7 REMOTE PLAYBACK
	4.3.8 3GPP
4.4 MONITORING SETTINGS	
4.5 RECORDING SCHEDULE	4.5.1 SPECIFIC DAY
	4.5.2 CHANNEL SCHEDULE
	4.5.3 I/O MONITOR
4.6 SEARCH/PLAYBACK	4.6.1 TIME MAP LIST
	4.6.2 LIST ALL
	4.6.3 MANUAL RECORDING LIST
	4.6.4 ALARM RECORDING LIST
	4.6.5 MOTION RECORDING LIST
	4.6.6 TIME SEARCH
	4.6.7 ADVANCED SEARCH
4.7 NETWORK	4.7.1 NETWORK STATUS
	4.7.2 CONNECTION SETTINGS
	4.7.3 WIRELESS SETTINGS
	4.7.4 ADVANCED TCP/IP
	4.7.5 UMTS SETTINGS
	4.7.6 DDNS SETTINGS
	4.7.7 MULTICAST SETTINGS
	4.7.8 WEB USER ACCOUNT INFO
4.8 ADVANCED	4.8.1 DATE AND TIME
	4.8.2 FIRMWARE SETTINGS
	4.8.3 STORAGE SETTINGS
	4.8.4 DISPLAY SETTINGS
	4.8.5 SPOT MONITOR SETTINGS
	4.8.6 ALERT SETTINGS
	4.8.7 SYSTEM SETTINGS
	4.8.8 SYSTEM LOG
	4.8.9 BACKUP

## 4.1 Channel Settings

In Channel Settings, you can adjust the device settings for each channel.

To set up a channel, press the **Menu** button on the Remote Control, select **CHANNEL SETTINGS**, press one **Channel** button (CH1 – CH4 for the four-channel unit; CH1 – CH8 for the eight-channel unit), and select one of the setting options. These setting options are described in the following.

### 4.1.1 Channel Name

Enter a descriptive name for the channel by using the on-screen keypad. Select **OK** from the on-screen keypad to save your settings.

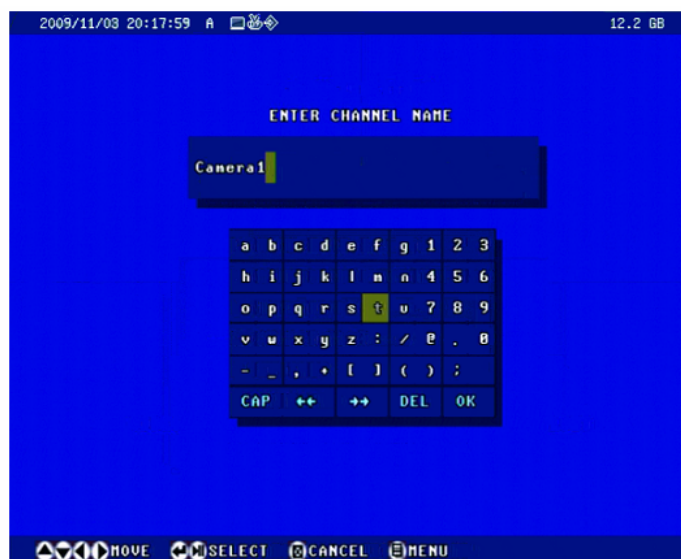

Figure 4-2

### 4.1.2 Video/Audio Settings

You can adjust the audio and video settings for the selected channel. Select **APPLY TO ALL** to apply the same settings to all four channels or all eight channels, depending on the unit you use.



Figure 4-3

- **VIDEO RESOLUTION:** Select the video resolution from 704 x 480, 704 x 240 and 352 x 240 for NTSC format; or 704 x 576, 704 x 288 and 352 x 288 for PAL format.
- **VIDEO FRAME RATE:** For the four-channel unit, select the frame rate from 2, 3, 5, 7.5, 10, 15 and 30 fps. For the eight-channel unit, select the frame rate from 2, 3, 5, 7.5, 10 and 15 fps.
- **Bandwidth Management:** Select the recording quality at different levels from POOR (VBR), FAIR (VBR), GOOD (VBR), GREAT (VBR), EXCELLENT (VBR), 128 KBPS (CBR), 256 KBPS (CBR), 768 KBPS (CBR), 1024 KBPS (CBR), and 1536 KBPS (CBR).
- **AUDIO RECORDING:** Enable the audio recording.
- **AUDIO VOLUME:** Select the audio volume from 0 to 14. Volume 7 is the default value.

### 4.1.3 Motion Detection

Motion detection is used to generate an alarm whenever movement occurs in the video image. You can configure up to 8 areas of different sensitive values for motion detection.

1. Select **MOTION DETECTION**. This screen appears. The default sensitivity value is 2 for the whole area.





Figure 4-4

2. To start motion detection settings, press the **▶** button.
3. To clear the default settings, press the **Stop** button. The message “NO BOXES EXIST” appears.
4. To define one detection area in the image, press the **▶** button.



Figure 4-5

## 4 OSD Menu Configurations

5. Press the directional buttons to place the detection area, and press the  button.
6. Press the directional buttons to modify the size of the detection area, and press the  button.

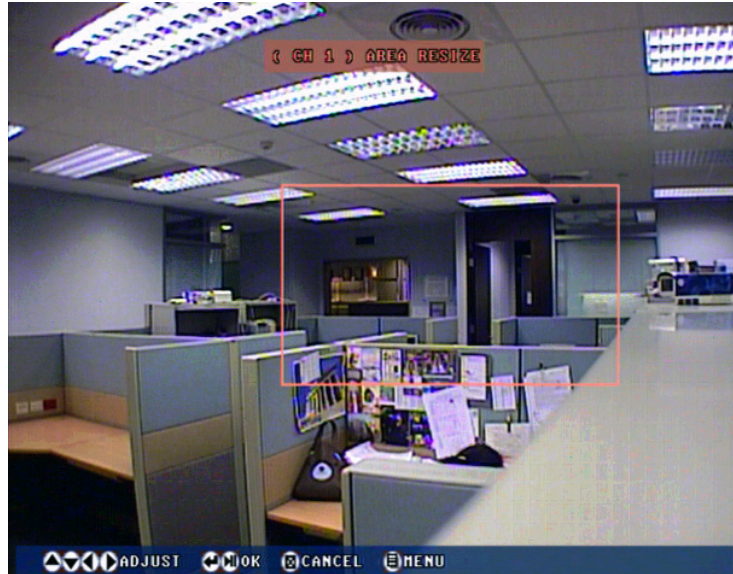

Figure 4-6



7. Select **SENSITIVITY** value from Low (1), Medium (2) and High (3), and press the  button. The higher the value, the more sensitive the detection area is to motion.



Figure 4-7

8. Press the **REC** button to save the settings.
9. To define another detection area with a different sensitivity value, select **MOTION DETECTION** again, press the  button, press the **Enter** button, and repeat Steps 4-8.



#### 4.1.4 Motion Trigger Output Settings

The alarm output can be triggered simultaneously when motion is detected. The four-channel unit can connect up to 4 alarm output devices, while the eight-channel unit can connect up to 8 alarm output devices. To activate the output settings, you must also start monitoring manually or by schedule. See *4.4 Monitoring Settings*.



Figure 4-8

### 4.1.5 Alarm Settings

You can capture images before and/or after a motion and an I/O event happens.



Figure 4-9

- **PRE-ALARM BUFFER:** Activate video recording before an event occurs. Set the recording time to 1 or 2 seconds.
- **POST-ALARM RECORDING:** Activate video recording onto the hard disk after an event occurs. Set the recording time from 1 to 30 seconds.
- **SPLIT INTERVAL:** Set the time length between each event file from 1 to 10 minutes.

### 4.1.6 Camera Settings

You can modify the video attributes of brightness, contrast, saturation and hue.



Figure 4-10

## 4.1.7 PTZ Settings

Through the RS-485 interface on the I/O terminal block, you can connect up to 4 PTZ cameras with the four-channel unit, and 8 PTZ cameras with the eight-channel unit. To set up the baud rate, speed and address, consult your PTZ documentation.



Figure 4-11

---

### Note:

1. Currently the GV-Compact DVR V3 does not support the PTZ camera with RS-232 interface.
  2. A total of 47 supported PTZ models are listed on the OSD. Using the Web interface, you have more options for supported models. For details, see *Supported PTZ Cameras*, Appendix F.
-

### 4.1.8 PTZ Control

After setting up the PTZ camera, you can press the **Channel** button (CH1 - CH4 for the four-channel unit; CH1 – CH8 for the eight-channel unit) on the remote Control to display the PTZ channel. Use the directional buttons to control the PTZ movement. Press the **Menu** button to access advanced functions. The availability of certain PTZ functions depends on different models. For details, consult your PTZ documentation.



Figure 4-12

## 4.1.9 Privacy Mask

You can set up the Privacy Mask to block out sensitive areas from view by covering the areas with black or white boxes in both live view and recorded clips.

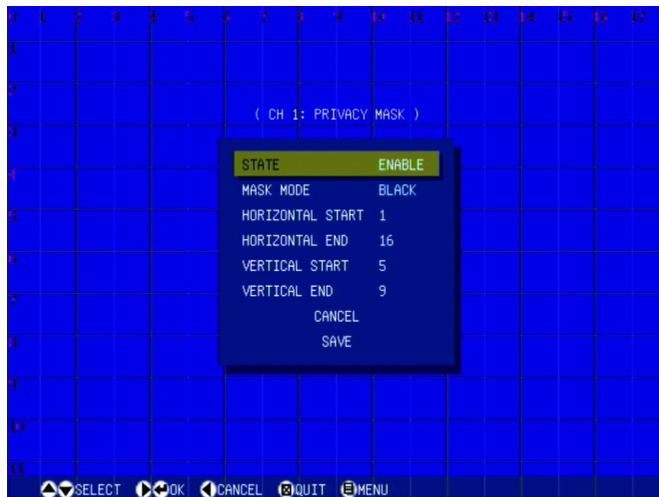

Figure 4-13

- **STATE:** Enable the Privacy Mask function.
- **MASK MODE:** Set the mask to be black or white.
- **HORIZONTAL START:** Set the value from 1 to 17 to define where the Privacy Mask starts horizontally. The value 1 is at the top; the value 17 is at the bottom.
- **HORIZONTAL END:** Set the value from 1 to 17 to define where the Privacy Mask ends horizontally. The value 1 is at the top; the value 17 is at the bottom.
- **VERTICAL START:** Set the value from 1 to 11 to define where the Privacy Mask starts vertically. The value 1 is at the left; the value 11 is at the right.
- **VERTICAL END:** Set the value from 1 to 11 to define where the Privacy Mask ends vertically. The value 1 is at the left; the value 11 is at the right.

## 4.2 Digital IO Settings

The I/O terminal block, on the rear panel of the GV-Compact DVR V3, provides the interface for the applications of digital input, relay output and GPS.

### 4.2.1 Digital Input Settings

The four-channel unit can connect up to 4 input devices, while the eight-channel unit can connect up to 8 input devices. To select one input device for setup, press the desired **Channel** button (CH1 – CH4 for the four-channel unit; CH1 – CH8 for the eight-channel unit) on the Remote Control.



Figure 4-14

- **STATE:** Enable the selected input.
- **NAME:** Enter a descriptive name for the input device.
- **NORMAL STATE:** Set the input state to OPEN CIRCUIT (normally open) or GROUNDED CIRCUIT (normally closed).
- **LATCH MODE:** Enable this mode to have a momentary output alarm.
- **TRIGGER RELAY:** Select the output(s) to be triggered once the input is activated.
- **RECORD:** Select the camera(s) to start recording once the input is activated.
- **CV2 Alert:** Select the camera(s) to send their images to Center V2 when the input is triggered.

Also see 6.2.1 I/O Control of the Web-based configuration which provides more information and features of the digital input settings.

## 4.2.2 Digital Output Settings

The four-channel unit can connect up to 4 output devices, while the eight-channel unit can connect up to 8 output devices. To select one output device for setup, press the desired **Channel** button (CH1 – CH4 for the four-channel unit; CH1 –CH8 for the eight-channel unit) on the Remote Control.

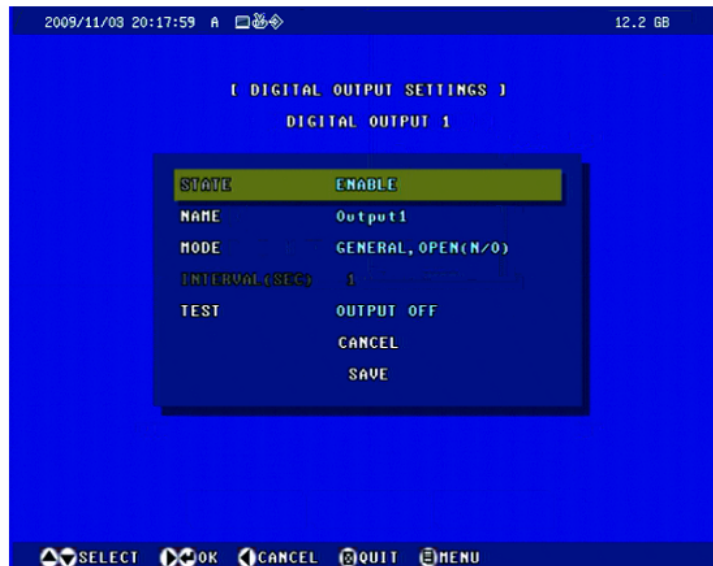

Figure 4-15

- **STATE:** Enable the selected output.
- **NAME:** Enter a descriptive name for the output device.
- **MODE:** Set the output mode to GENGERAL, OPEN (N/O); GENERAL, GROUNDED (N/C); TOGGLE, OPEN (N/O); TOGGLE, GROUNDED (N/C); PULSE, OPEN (N/O); PULSE, GROUNDED (N/C).
- **INTERVAL:** Specify the pulse duration for the pulse mode from 1 to 60 seconds.
- **TEST:** After finishing the above settings, select this option to see if the output device has response.

Also see *6.2.1 I/O Control* of the Web-based configuration which provides more information and features of the digital output settings.

### 4.2.3 GPS Settings

Note the GPS function is only supported on Anti-Vibration ACC models (GV-LX4C3V / GV-LX8CV1 / GV-LX8CV2).

The Anti-Vibration ACC models support the Global Position System (GPS) for active vehicle tracking and location verification. You can track the vehicle location on Google maps and display the average speed of a vehicle in live view.



Location tracking on Google maps



Vehicle speed in live view

Figure 4-16



Figure 4-17



- **STATE:** Enable the GPS function. After the settings, the vehicle speed will show on the upper-right corner of the main screen.
- **BAUD RATE:** Two baud rate options are available: 4800 and 9600. By default the value is 9600.
- **UPDATE PERIOD:** Set the update frequency in seconds for GPS data.
- **SPEED UNIT:** Two speed unit options are available: km/h and mph. By default the value is km/h.
- **SYNC TIME:** Synchronizes the time of GV-Compact DVR V3 with the GPS time once the unit receives GPS signals. After enabling this function, every time you restart the unit, it will synchronize the time with the GPS time automatically.

To track the location of the GV-Compact DVR V3 on Google Maps, see [8.3 GPS Tracking](#). If the monitoring is also activated, the GPS tracks will be recorded along with videos. This makes it possible to play back video with GPS tracks on maps using the Remote ViewLog player. See [7.2.5 Playback of GPS Tracks](#).

---

**Note:** The vehicle speed will be recorded with video, but the review of the speed data is not available on OSD. You can retrieve the video with the speed data using the Remote ViewLog player. See [7.2.2 Playback over Network](#).

---

### 4.3 Events and Alerts

For the events of motion detection or I/O trigger, you can set up these alert methods:

1. Send a captured still image by e-mail or FTP.
2. Notify Center Monitoring Station, Center V2, VSM or GV-GIS, by video or text alerts.

To have above alert methods, you must also set the following features:

- Motion Detection (See 4.1.3 *Motion Detection*)---optional
- Input Setting (See 4.2.1 *Digital Input Settings*)
- For e-mail and FTP alerts, it is required to start monitoring (see 4.4 *Monitoring Settings*)

---

**Note:** The Motion Detection function is an optional setting and it is activated by default.

---

### 4.3.1 E-mail

After a trigger event, the GV-Compact DVR V3 can send the e-mail to a remote user containing a captured still image.

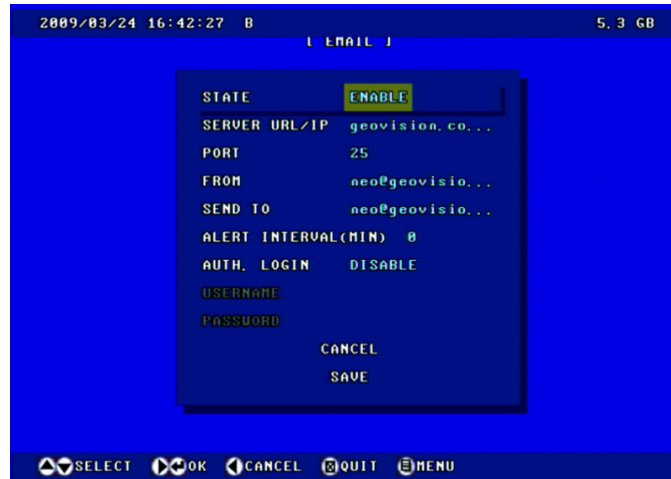

Figure 4-18

- **STATE:** Enable the e-mail function.
- **SERVER URL/IP:** Enter the URL or IP address of the SMTP server.
- **PORT:** Enter the SMTP server's port number. Or keep the default value 25.
- **FROM:** Enter the sender's e-mail address.
- **SEND TO:** Enter the e-mail address(s) you want to send alerts to.
- **ALERT INTERVAL:** Enter the interval between e-mail alerts. The interval can be between 0 and 60 minutes. The option is useful for the frequent event condition. It will ignore any event triggers during the interval period.
- **AUTH LOGIN:** If the SMTP server needs authentication, enable this option and enter the valid username and password.

Also see 6.3.1 *E-mail* of the Web-based configuration which provides more information and features of the e-mail settings.

### 4.3.2 FTP

You can also send the captured still image to a remote FTP server for alerts.

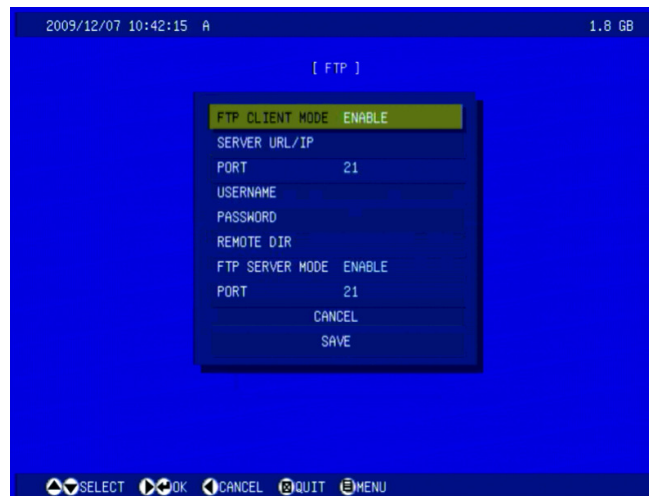

Figure 4-19

- **FTP CLIENT MODE:** Enable the FTP function.
- **SERVER URL/IP:** Enter the host name or IP address of the FTP Server.
- **PORT:** Enter the port number of the FTP Server. Or keep the default value 21.
- **USERNAME:** Enter a valid user name to log into the FTP Server.
- **PASSWORD:** Enter a valid password to log into the FTP Server.
- **REMOTE DIR:** Enter the name of the storage folder on the FTP Server.
- **FTP SERVER MODE:** Enable the GV-Compact DVR V3 to act as a FTP Server, allowing users to download the AVI files.
- **PORT:** Modify the port of the built-in FTP Server. Or keep the default value 21.

Also see 6.3.2 *FTP* of the Web-based configuration which provides more information and features of the FTP settings.

### 4.3.3 Center V2

After a motion or an I/O triggered event, the central monitoring station Center V2 can get notified by live videos and text alerts. For the monitoring through Center V2, you must already have a subscriber account on Center V2.

You can connect up to two Center V2 servers for central monitoring. Press **CH1** and **CH2** buttons on the Remote Control for two different connection settings.



Figure 4-20

- **ACTIVATE LINK:** Enable the monitoring through Center V2 for alert events.
- **HOSTNAME/IP:** Enter the host name or IP address of Center V2.
- **PORT:** Enter the port matching the **Port 2** on Center V2. Or keep the default value 5551. Refer to *11.1 Center V2*.
- **USERNAME:** Enter a valid user name to log into Center V2.
- **PASSWORD:** Enter a valid password to log into Center V2.

Using the Web interface, you can set up the connection schedule. For more information and features of the Center V2 connection, see *6.3.3 Center V2* of the Web-based configuration.

### 4.3.4 VSM

After a motion or an I/O triggered event, the central monitoring station VSM can get notified by text alerts. For the monitoring through VSM, you must already have a subscriber account on VSM.

You can connect up to two VSM servers for central monitoring. Press **CH1** and **CH2** buttons on the Remote Control for two different connection settings.



Figure 4-21

- **ACTIVATE LINK:** Enable the monitoring through VSM for alert events.
- **HOSTNAME/IP:** Enter the host name or IP address of VSM.
- **PORT:** Enter the port matching the **Port 2** on VSM. Or keep the default value 5609. Refer to 11.2 VSM.
- **USER NAME:** Enter a valid user name to log into VSM.
- **PASSWORD:** Enter a valid password to log into VSM.

Using the Web interface, you can set up the connection schedule. For more information and features of the VSM connection, see 6.3.4 VSM of the Web-based configuration.

### 4.3.5 GV-GIS

Note the GV-GIS function is only supported on Anti-Vibration ACC models (GV-LX4C3V, GV-LX8CV1 and GV-LX8CV2).

Through the network connection, the Anti-Vibration ACC models equipped with GPS devices can send GPS data and live video to the GV-GIS (Geographic Information System) for the services of vehicle tracking, location verification and live monitoring.

You can connect up to two GV-GIS servers for central monitoring. Press **CH1** and **CH2** buttons on the Remote Control for two different connection settings.



Figure 4-22

- **ACTIVATE LINK:** Enable the monitoring through GV-GIS.
- **HOSTNAME/IP:** Enter the host name or IP address of GV-GIS.
- **PORT:** Enter the port matching that on GV-GIS. Or keep the default value 5609.
- **USER NAME:** Enter a valid user name to log into GV-GIS.
- **PASSWORD:** Enter a valid password to log into GV-GIS.

Using the Web interface, you can set up the connection schedule. For more information and features of the GV-GIS connection, see 6.3.5 GV-GIS of the Web-based configuration.

### 4.3.6 Video Gateway / Recording Server

You can send the video images to the GV-Video Gateway or GV-Recording Server.

Up to two GV-Video Gateways or GV-Recording Servers can be connected with the unit.. Press **CH1** and **CH2** buttons on the Remote Control for two different connection settings.



Figure 4-23

- **Activate Link:** Enable the connection to the GV-Video Gateway or GV-Recording Server.
- **HOSTNAME/IP:** Enter the host name or IP address of GV-Video Gateway or GV-Recording Server.
- **PORT:** Enter the port matching that on GV-Video Gateway or GV-Recording Server. Or keep the default value 50000.
- **USER NAME:** Enter a valid user name to log into GV-Video Gateway or GV-Recording Server.
- **PASSWORD:** Enter a valid password to log into GV-Video Gateway or GV-Recording Server.

Using the Web interface, you can set up the connection schedule. For more information and features of the GV-Video Gateway and GV-Recording Server connection, see 6.3.7 *Video Gateway / Recording Server* of the Web-based configuration.



### 4.3.7 Remote Playback

You can remotely access and play the recorded files saved on the GV-Compact DVR V3

Select **YES** to activate the remote playback server built in the unit and to allow playback access. Keep the default port 5552 or modify it if necessary. For details on the remote playback, see 7.2.2 *Playback over Network*.

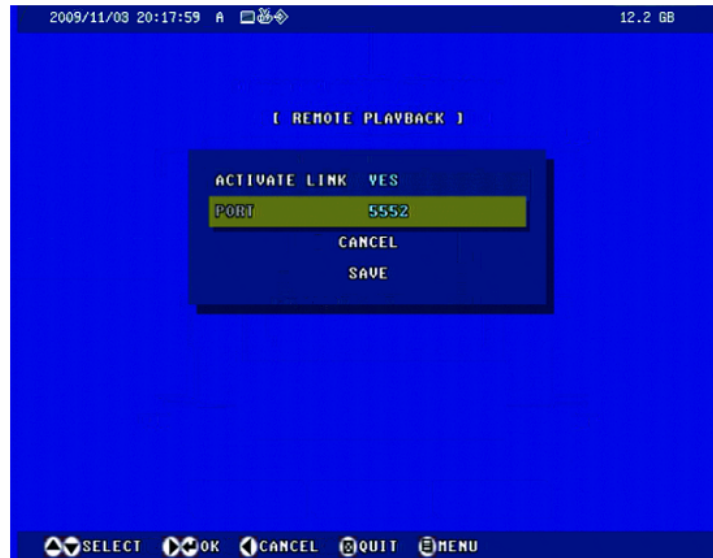

Figure 4-24

### 4.3.8 3GPP

The 3GPP server allows you to enable the Real Time Stream Protocol (RTSP) and watch live streaming by using VLC or QuickTime player. For the RTSP command, see *RTSP Protocol Support* in Appendix E.

---

#### Note:

1. Currently the GV-Compact DVR V3 does not support 3GPP mobile connection.
  2. In four-channel models, you can only enable either RTSP or Multicast; the two protocols cannot function at the same time.
  3. In eight-channel modes, when 3GPP server (RTSP protocol) is enabled, you cannot access the live view through the Web interface at the same time.
- 



Figure 4-25

- **ACTIVATE LINK:** Enable the RTSP protocol.
- **RTSP/TCP PORT:** Keep the default value 8554, or modify it if necessary.
- **RTP/UDP PORT:** Keep the default range from 17300 to 17319, or modify it if necessary. The number of ports for use is limited to 20.
- **MAX CONNECTION:** Set the maximum number of RTSP connections to the GV-Compact DVR V3. The maximum value is 20.

## 4.4 Monitoring Settings

You can start recording manually, by schedule or by input trigger.

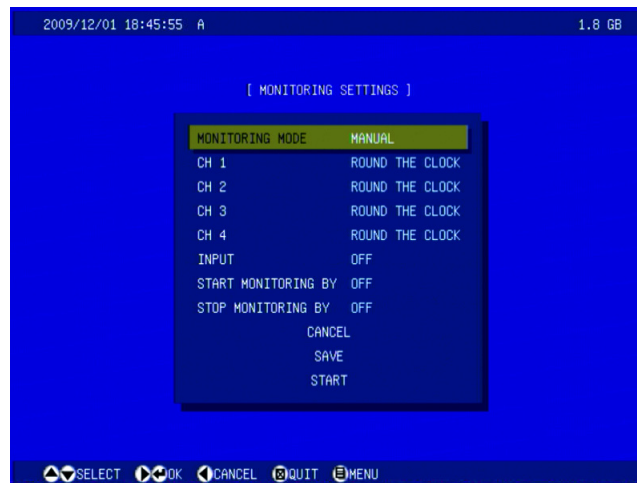

Figure 4-26

### ■ MONITORING MODE:

- Select **MANUAL** to manually start recording or I/O monitoring. If you choose this option, configure the following item **CHANNEL** (CH 1 – CH 4 for the four-channel unit, or CH 1 – CH 8 for the eight-channel unit) or **INPUT**.
- Select **SCHEDULE** to start recording and I/O monitoring by the schedule you set up. To configure recording schedule, see *4.5 Recording Schedule*.

■ **CHANNEL:** Available only in **MANUAL** monitoring mode. Select the desired channel (CH 1 – CH 4 for the four-channel unit, or CH 1 – CH 8 for the eight-channel unit), and set its recording mode to be motion detection or round-the-clock. You can also select to turn off the channel for monitoring.

■ **INPUT:** Available only in **MANUAL** monitoring mode. Select **ON** to start I/O monitoring manually. When the input is triggered, its associated cameras and outputs will also be enabled for recording and alerting. For input settings, see *4.2.1 Digital Input Settings*.

■ **START MONITORING BY:** Start monitoring with a triggered input. When the assigned input is triggered, the system will response based on your settings in either **MANUAL** or **SCHEDULE** monitoring mode.

■ **STOP MONITORING BY:** Stop monitoring with a triggered input. When the assigned input is triggered, the system will stop monitoring.

### To start monitoring or recording:

- Select **START**. The unit will start monitoring based on your above settings: record immediately, only record on the scheduled time, or record by an input trigger.
- Select **SAVE** to save the monitoring settings. Then press the **REC** button on the Remote Control at any time to start your monitoring settings.

Also see *6.4 Monitoring of the Web-based configuration* which provides more information and features of the monitoring settings.

## 4.5 Recording Schedule

The schedule is provided to activate recording and I/O monitoring on a specific time each day.

### 4.5.1 Specific Day

The system will operate automatically on the specific days you have scheduled. Press the  button on the Remote Control to start setting and then use the directional buttons to define the days. To enable the camera and I/O monitoring on the defined days, see **SPECIFIC DAY** options in 4.5.2 *Channel Schedule* and 4.5.3 *I/O Monitoring Schedule*.

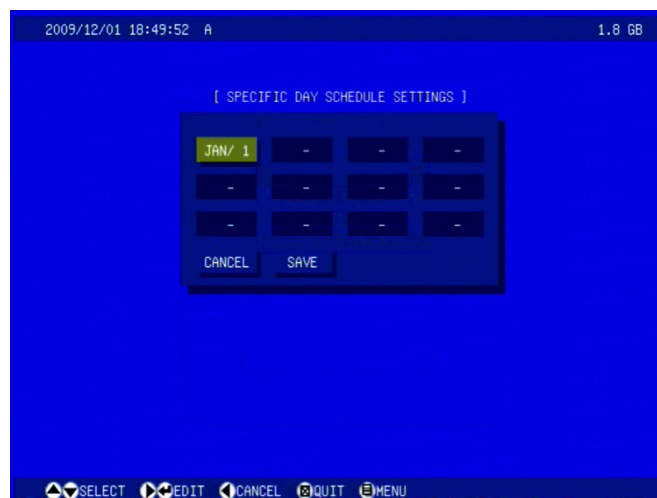



Figure 4-27

### 4.5.2 Channel Schedule

You can set up different monitoring schedules for each camera. Press the **Channel** button (CH1 – CH4 for the four-channel unit; CH1 – CH8 for the eight-channel unit) on the Remote Control to select one channel for setup.



Figure 4-28

- **Span 1- Span 3:** Sets different recording modes for each time frame during the day. Each day can be divided into 3 time frames, represented by Span 1 to Span 3.
- **Weekend:** If you want to have the camera monitoring all day during the weekend, enable this option and select the recording mode to be used on the weekend. Define whether your weekend includes Saturday and Sunday (SAT-SUN) or Only Sunday (SUN).
- **Recording mode:** round-the-clock icon , motion detection icon .
- **Specific Day:** Enable the camera monitoring only on the specified days. To set the specific days, see 4.5.1 *Specific Day*.

To start the scheduled recording, you must set the monitoring mode to be **SCHEDULE**. See 4.4 *Monitoring Settings*.

---

**Note:** The recording mode you set will be indicated on the main screen when the monitoring is started. For details, see 3.8 *Main Screen Overview*.

---

### 4.5.3 I/O Monitoring Schedule

You can set up the schedule for I/O monitoring to start.

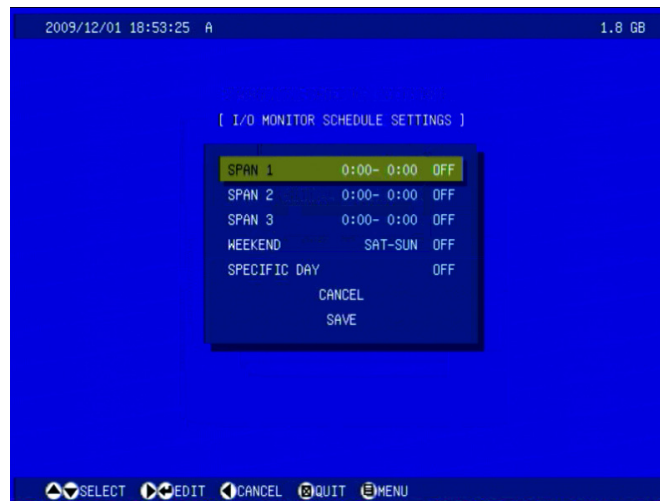

Figure 4-29

- **Span 1- Span 3:** Set different time frames during the day to enable I/O monitoring. Each day can be divided into 3 time frames, represented by Span 1 to Span 3.
- **Weekend:** If you want to have the I/O monitoring all day during the weekend, enable this option and define whether your weekend includes Saturday and Sunday (SAT-SUN) or Only Sunday (SUN).
- **Specific Day:** Enable the I/O monitoring only on the specified days. To set the specific days, see 4.5.1 *Specific Day*.

To start the scheduled recording, you must set the monitoring mode to be **SCHEDULE**. See 4.4 *Monitoring Settings*.

## 4.6 Search / Playback

You can retrieve the recorded video by date, time and event. To access the SEARCH/PLAYBACK menu, press the **Menu** button or the **Search** button on the Remote Control.

### 4.6.1 Time Map List

The Time Map List provides an overview of the recorded videos in the form of a calendar.

1. On the calendar, dates for which there are recorded videos are green. Use the directional buttons on the Remote Control to move the focus, and select the desired Year, Month and Day. Then press the  button.

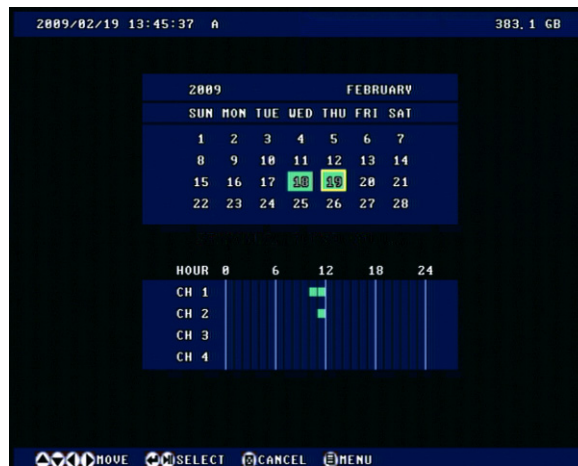



Figure 4-30

2. In the HOUR section, hours for which there are recorded videos are green. Each column represents 1 hour. Select the desired hour and press the  button.

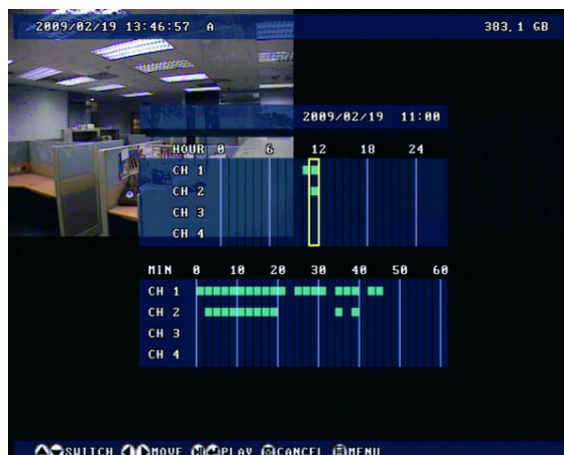



Figure 4-31

3. In the MIN section, minutes for which there are recorded videos are green. Each column represents 2 minutes. Select the desired minute and press the  button to start playback.



## 4.6.2 List All

The list displays a complete list of recorded videos. To move the list screen up and down one page, press the right and left directional buttons on the Remote Control. To start playback, highlight the desired video and press the  button.

## 4.6.3 Manual Recording List

The list displays a complete list of manually recorded videos. To move the list screen up and down one page, press the right and left directional buttons on the Remote Control. To start playback, highlight the desired video and press the  button.

## 4.6.4 Alarm Recording List

The list displays a complete list of recorded videos on input trigger. To move the list screen up and down one page, press the right and left directional buttons on the Remote Control. To start playback, highlight the desired video and press the  button.

## 4.6.5 Motion Recording List

The list displays a complete list of recorded videos on motion detection. To move the list screen up and down one page, press the right and left directional buttons on the Remote Control. To start playback, highlight the desired video and press the  button.

## 4.6.6 Time Search

You can locate the recorded videos within a certain date and time. Enter **START TIME** and **END TIME** for the time search. Then define how to display the found videos. Select **LIST** to display a list of found videos, or **PLAY** for immediate playback.

### 4.6.7 Advanced Search

You can limit your search by defining search criteria.

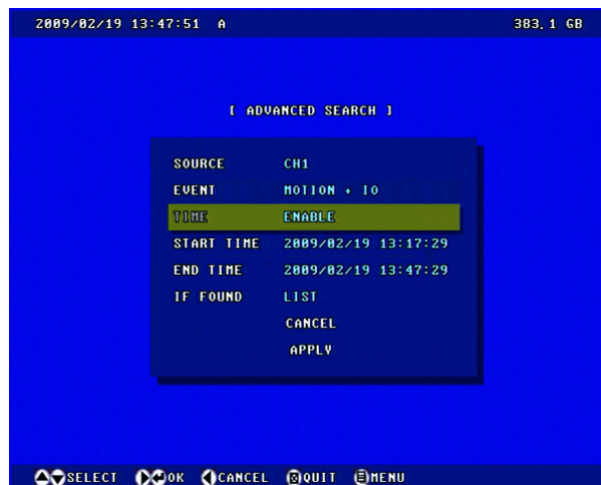

Figure 4-32

- **SOURCE:** Search the recorded video from the selected channel or all channels.
- **EVENT:** Select the type of recorded videos with the options of motion detection and input trigger (MOTION + IO), motion detection (MOTION), any input triggered (ALL IO) or an individual input triggered (e.g. IO 1 for input 1 triggered).
- **TIME:** Enable this option to define a period of time.
- **START TIME:** Set the starting time of the video search.
- **END TIME:** Set the ending time of the video search.
- **IF FOUND:** Set how to display the found videos. Select **LIST** to display a list of found videos, or **PLAY** for immediate playback.

## 4.7 Network

The GV-Compact DVR V3 allows you to use a Web browser to remotely view and manage the system. For remote access, configure the related network settings in this section.

### 4.7.1 Network Status

The Network Status displays the current network settings of GV-Compact DVR V3.

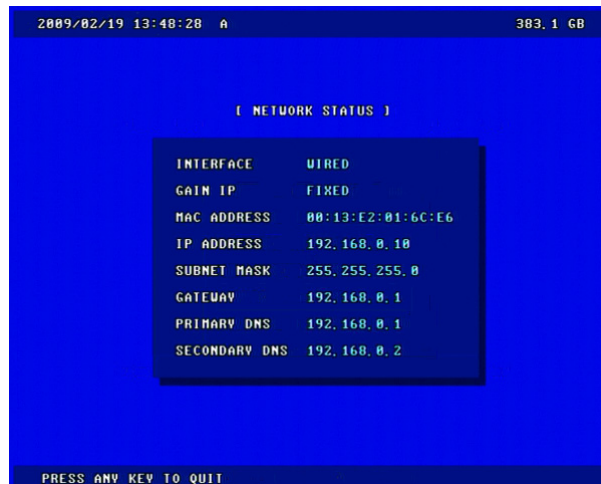

INTERFACE	WIRED
GAIN IP	FIXED
MAC ADDRESS	00:13:E2:01:6C:E6
IP ADDRESS	192.168.0.10
SUBNET MASK	255.255.255.0
GATEWAY	192.168.0.1
PRIMARY DNS	192.168.0.1
SECONDARY DNS	192.168.0.2

Figure 4-33

### 4.7.2 Connection Settings

According to your network environment, select among Static IP, DHCP and PPPoE to configure an IP address to the GV-Compact DVR V3.



Figure 4-34

- **CONNECTION:** According to the network environment, select **WIRED** or **WIRELESS**. Before enabling **WIRELESS**, configure **WIRELESS SETTINGS** which is explained in the following section.
- **GAIN IP:**
  - **FIXED:** Assign a static IP or fixed IP to the GV-Compact DVR V3. Enter the GV-Compact DVR V3's static IP address, subnet mask, gateway, primary DNS and secondary DNS.
  - **DHCP:** Assign a dynamic IP by the DHCP server. The option is enabled by default. The assigned IP address remains unchanged unless you disconnect the unit from the network. You can check the current IP assigned by the DHCP server at the **Network Status** screen (figure 4-33) before you log in its Web interface. For the dynamic IP, it is suggested to use the DDNS function to get a domain name that always links to the unit's changing IP address. To enable the DDNS function, see *4.7.6 DDNS Settings*.
  - **PPPoE:** The Network environment is xDSL connection. Enter the username and password provided by your ISP to establish the connection. If you use the xDSL connection with dynamic IP addresses, it is highly suggested to enable the DDNS function that links a domain name to the unit's changing IP address. To enable the DDNS function, see *4.7.6 DDNS Settings*.

### 4.7.3 Wireless Settings

To use the wireless function, a wireless LAN USB Adaptor is required. For supported wireless LAN adaptors, see *Appendix A*.



Figure 4-35

- **NETWORK TYPE:** Select AD HOC or INFRASTRUCTURE for the network mode.
  - **AD HOC:** A Peer-to-Peer mode. This mode connects to other computer with the WLAN card, and does not need the Access Point to connect to each other.
  - **INFRASTRUCTURE:** Via the Access Point to connect to the Internet. This mode further gives wireless access to the Internet or data sharing under a previously wired environment.
- **ACCESS POINT SURVEY:** Search all the available Access Points (Infrastructure mode) and wireless stations (AD-Hoc mode) within the range of your WLAN card.
- **NAME (SSID):** The SSID (Service Set Identity) is a unique name that identifies a particular wireless network. Enter SSID of the Wireless LAN group or Access Point you are going to connect to.
- **AUTH. TYPE:** Select one of these network authentication and data encryption: DISABLE, WEP, WPASPSK-AES, WPA2PSK-TKIP or WPA2PSK-AES.
  - **WEP:** Abbreviated for Wired Equivalent Privacy, this is a type of data encryption. Type up to 4 WEP keys in HEX or ASCII format. Note that if you use HEX format, only digits 0-9, letters A-F and a-f are valid.
  - **WPASPSK-AES or WPA2PSK-AES:** Type WPA-PSK (Pre-Shared Key) for data encryption.
  - **WPA2PSK-TKIP:** Type WPA-PSK (Pre-Shared Key) for data encryption.

---

**Note:**

1. Your encryption settings must match those used by the Access Points or wireless stations with which you want to associate.
  2. When you lose the wireless access, you can still access the unit by connecting it to a LAN and logging in with the default IP address 192.168.0.10.
-

#### 4.7.4 Advanced TCP/IP

You can set up the advanced TCP/IP settings, including DDNS server, HTTP port, streaming port and UPnP.

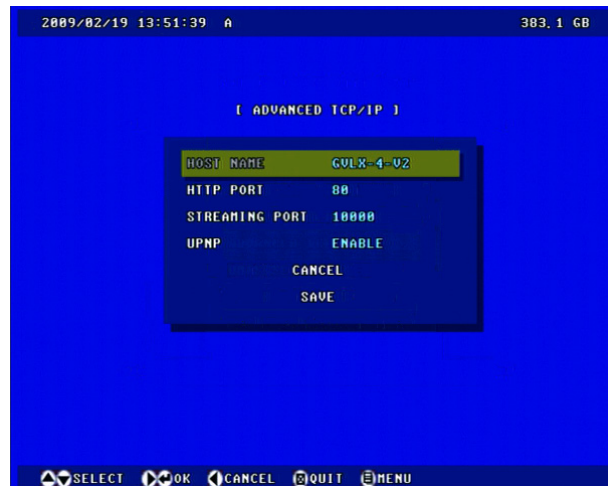

Figure 4-36

- **HOST NAME:** Enter a descriptive name for the GV-Compact DVR V3.
- **HTTP PORT:** The HTTP port enables connecting the GV-Compact DVR V3 to the Web. For security integration, the Administrator can hide the server from the general HTTP port by changing the default HTTP port of 80 to a different port number within the range of 1024 thru 65535.
- **STREAMING PORT:** The port enables connecting the GV-Compact DVR V3 to the GV-System. The default setting is 10000.
- **UPNP:** UPnP (Universal Plug & Play) is a networking architecture that provides compatibility among networking equipment, software and peripherals of the 400+ vendors that are part of the Universal Plug and Play Forum. It means that they are listed in the network devices table for the operating system (such as Windows XP) supported by this function. Enabling this function, you can connect to the GV-Compact DVR V3 directly by clicking on the GV-Compact DVR V3 listed in the network devices table.

---

**Note:** The GV-Compact DVR V3 also supports **HTTPS** and **QoS** protocols. For these protocol settings, see [6.7.3 Advanced TCP/IP](#) of the Web-based configuration.

---

## 4.7.5 UMTS Settings

After a mobile broadband device (supporting UMTS, HSDPA and etc) is attached to the USB port on the GV-Compact DVR V3 and the UMTS function is enabled, the GV-Compact DVR V3 can have Internet connectivity. For the supported mobile broadband devices, see *Appendix B*.



Figure 4-37

- **STATE:** Enable the UMTS function.
- **PIN NUMBER:** Enter the PIN number that is provided by your network operator.
- **APN:** Enter the Access Point Name (APN) that is provided by your network operator.
- **USERNAME:** Enter a valid username to enable the UMTS service from your network operator.
- **PASSWORD:** Enter a valid password to enable the UMTS service from your network operator.
- **MTU:** Enter the Maximum Transfer Unit (MTU). The default value is 1500.
- **IP Address:** The IP address of the GV-Compact DVR V3 will be displayed after the UMTS service is enabled. The next time when you want to log in the GV-Compact DVR V3, you need to enter the IP address into your browser. If you use the UMTS connection with dynamic IP addresses, it is highly suggested to enable the DDNS function that links a domain name to the unit's changing IP address. For details on DDNS, see *4.7.6 DDNS Settings*.

Also see *6.7.4 UMTS/ZigBee* of the Web-based configuration which provides more information and features of the UMTS connection.

### 4.7.6 DDNS Settings

DDNS (Dynamic Domain Name System) provides a convenient way of accessing the GV-Compact DVR V3 when using a dynamic IP. DDNS assigns a domain name to the unit, so that the Administrator does not need to go through the trouble of checking if the IP address assigned by DHCP server or ISP (in xDSL connection) has changed.

Before enabling the DDNS function, the Administrator should apply for a Host Name from the DDNS service provider's website. There are 2 providers listed on the GV-Compact DVR V3: **GeoVision DDNS Server** (<http://ns.dipmap.com/register.aspx>) and **DynDNS.org** (<http://www.dyndns.com/>).



Figure 4-38

- **STATE:** Enable the DDNS function.
- **PROVIDER:** Select the DDNS service provider you have registered with.
- **HOSTNAME:** Enter the host name used to link to the GV-Compact DVR V3. For the users of GeoVision DDNS Server, it is unnecessary to fill the field because the system will detect the host name automatically.
- **USERNAME:** Enter a valid user name used to enable the service from the DDNS.
- **PASSWORD:** Enter a valid password used to enable the service from the DDNS.



## 4.7.7 Multicast Settings

Note the Multicast function is only supported on the **four-channel** GV-Compact DVR V3. You can enable either Multicast or RTSP; the two protocols cannot function at the same time.

The multicast provides a mechanism for sending a single video and audio stream to a group of hosts. Only the hosts that have joined a multicast group can send and receive the multicast streams. The multicast streams are only sent to the hosts on a local network.

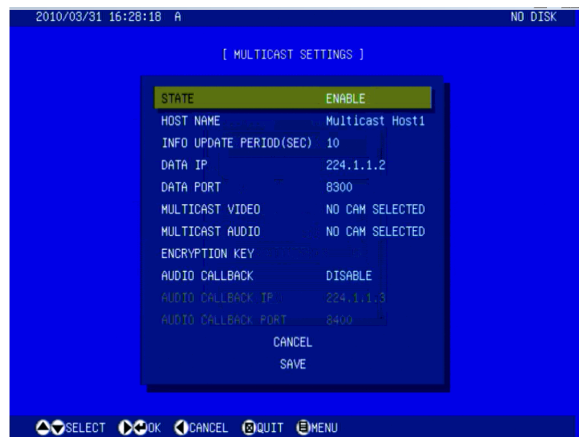

Figure 4-39

- **STATE:** Enable the Multicast function.
- **HOST NAME:** Name the GV-Compact DVR V3 in a multicast group.
- **INFO UPDATE PERIOD:** Enter the time length between each update of multicast streams.
- **DATA IP:** Enter the IP address used for multicasting. The default IP address is 224.1.1.2.
- **DATA PORT:** Enter the port used for multicasting. The default value is 8300.
- **MULTICAST VIDEO:** Select the camera to send its video through multicasting.
- **MULTICAST AUDIO:** Select the audio to send its audio through multicasting.
- **ENCRYPTION KEY:** Enter an Encryption Key to secure multicast streams. The hosts in the multicast group will need to enter the Key to access the video and audio streams.
- **AUDIO CALLBACK:** Enable this option to receive audio broadcasting from the hosts in the multicast group. Specify the IP address and port number to receive the audio broadcast. The default IP address is 224.1.1.3 and port number is 8400.

Also see 6.7.5 *Multicast* of the Web-based configuration which provides more information and features of the Multicast function.

### 4.7.8 Web User Account Info

You can change the login name and password of Administrator, Guest and FTP Server User.

- The default Administrator login name and password are **admin**.
- The default Guest login name and password are **guest**.
- The default FTP Server login name and password are **ftpuser**.



Figure 4-40

## 4.8 Advanced

In this section, you can configure the settings of date and time, storage device, screen display, and system password. In addition, you can view and upgrade the firmware.

### 4.8.1 Date and Time

The date and time settings are used for date and time stamps on the image.



Figure 4-41

- **SET BY:** Select **MANUAL** to adjust the data and time by yourself, or **NETWORK** to synchronize the date and time with a time server. If you select **NETWORK**, then the option of **SERVER** appears. Use the on-screen keypad to enter the IP address of the time server.
- **DAY LIGHT SAVING:** Automatically adjust the GV-Compact DVR V3 for daylight saving time. Enter the Start and End time of daylight saving.

---

**Note:** The default setting with the time server can avoid the system time delay. If your GV-Compact DVR is not networked or the time server is not enabled, the system time may delay about 1.5 second every 24 hours. In such case, you could update the system time manually to ensure exact recording time.

---

Also see *7.2.4 Playback of Backup Files* of the Web-based configuration which provides more information and features of the date and time settings.

### 4.8.2 Firmware Settings

GeoVision will periodically release the updated firmware on the website. The new firmware can be simply loaded into the GV-Compact DVR V3 by using a USB storage device.

For the details on upgrading the unit over the network, see *Chapter 8 Advanced Applications*.

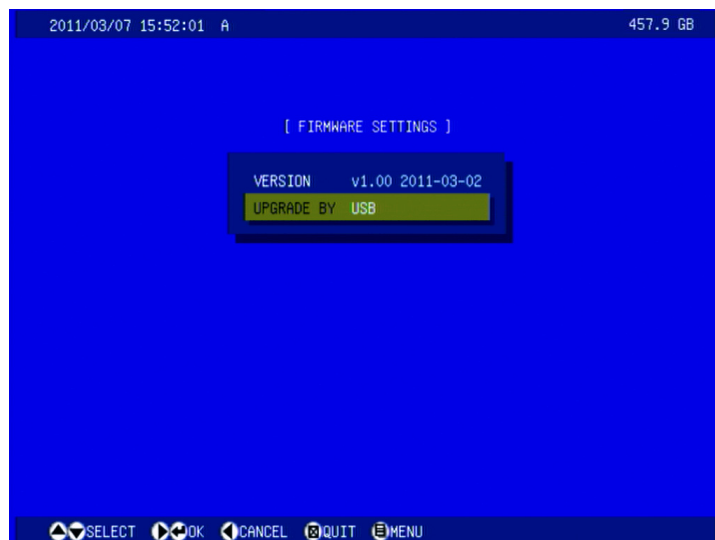

Figure 4-42

---

Note: The time for different USB storage devices to be recognized may vary.

---

### 4.8.3 Storage Settings

You can configure the settings of the connected hard disk drive.



Figure 4-43

- **STORAGE STATUS:** Display the total size and space usage of the hard drive.
- **STORAGE MANAGEMENT:** This option allows you to format the hard disk. For details, see *3.6 Formatting Hard Drive*.
- **RECYCLING:** If the option is enabled, the system will either write the data to another device or overwrite the oldest recorded files when the disk space is lower than the specified space limit. If the option is disabled, the system will stop recording when the specified space limit is reached.
- **CAPACITY WARNING:** Specify the space limit to be warned about. The space limit options include 256 MB, 512 MB, 1 GB, 2 GB and 5 GB.
- **KEEP DAYS:** Specify the days to store the files from 1 day to 255 days. When both **Keep days** and **Enable Recycle** are selected, the system applies whichever condition comes first. For example, if the specified smallest amount of storage space comes earlier than the designated keep days, then recycle is applied first.

---

**Note:**

1. If **RECYCLING** is enabled, the available space of the hard disk must be higher than the space you specified at the **CAPACITY WARNING** option. Otherwise no video will be recorded.
  2. When the disk is full, the **Disk Full / Fault LED** on the front panel will turn on and the information of hard disk status on the top right of the screen will turn to red.
-

### 4.8.4 Display Settings

You can show or hide the time, date, disk space, camera information and specific cameras appearing on the screen.

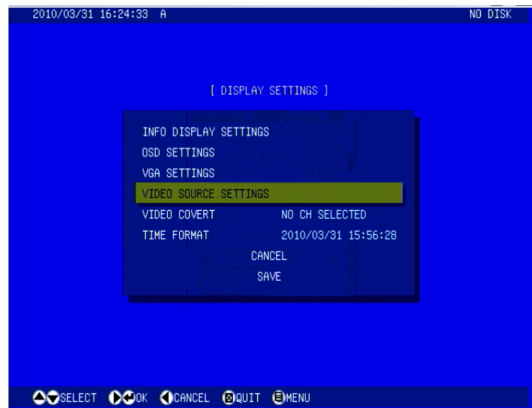

Figure 4-44

**INFO DISPLAY SETTINGS:** Show or hide the information of date and time, hard disk space, channel number, GV-Smart Box counting data and camera name on the image. The **INSTRUCTIONS** option allows you to show or hide the legend at the bottom of the screen.

- **OSD SETTINGS:** Change the look of OSD menu on the screen.
  - ⊙ **3D EFFECT:** Select YES to emboss the menu options.
  - ⊙ **BORDER:** Show or hide the borders among the 4-split or 8-split channels.
  - ⊙ **OSD TIMEOUT:** When the OSD menu remains stationary for the specified time, it will close automatically. The options include 3 MIN, 7 MIN, 15 MIN and NEVER.
  - ⊙ **IR TYPE:** Set the unit to be Type A, B, or C device. The setting allows you to control multiple GV-Compact DVR V3s with one Remote Control. Use the **A, B, C Device Type** buttons on the Remote Control to switch among devices.
  - ⊙ **DEFAULT VIEW MODE:** Set the view mode to the Single or Quad view for the four-channel unit; set the view mode to the Single or Multi view for the eight-channel unit. You need to restart the system to apply the view mode.
  - ⊙ **DEFAULT CHANNEL:** Select the desired channel to be shown in the Single view when the Single view is set up as the default view mode.
  - ⊙ **VGA SETTINGS:** Select the video resolution on the VGA monitor. The option includes 800 x 600, 1024 x 768 and 1280 x 1024.
- **VIDEO SOURCE SETTINGS:** Assign the video input to the desired video channel for display. Note the 8-channel unit does not support this feature.
- **VIDEO COVERT:** Hide the selected camera on the screen but keep on recording video from the camera.
- **TIME FORMAT:** Select one of the four display formats.

## 4.8.5 Spot Monitor Settings

You can configure the settings when a spot monitor is connected to the GV-Compact DVR V3.

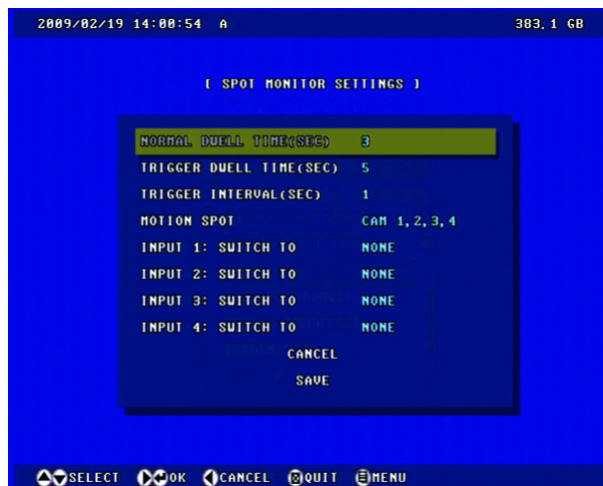

Figure 4-45

- **NORMAL DWELL TIME:** Select the amount of time that each video remains on the spot monitor before the GV-Compact DVR V3 switches to the next video in a rotation. The dwell time can be between 1 and 5 seconds.
- **TRIGGER DWELL TIME:** Select the amount of time that the video remains on the spot monitor after the motion or I/O triggered event occurs. The triggered dwell time can be between 1 and 5 seconds.
- **TRIGGER INTERVAL:** Select the interval between triggered events from 1 to 5 seconds. During the specified length of time, all the triggered events will be ignored. The triggered event after the interval will be displayed on the spot monitor.
- **MOTION SPOT:** Select the cameras to be displayed upon motion events.
- **INPUT X:** Select the associated camera to be displayed when an input is triggered.

### 4.8.6 Alert Settings

The system buzzer can be activated automatically under these conditions: video lost, input devices triggered, motion detected, disk full and disk write error. The duration of buzzing sounds is definable. When the buzzer starts beeping, pressing any button on the Remote Control can stop it.



Figure 4-46



## 4.8.7 System Settings

You can set up video format, change the system password and reset the configurations.

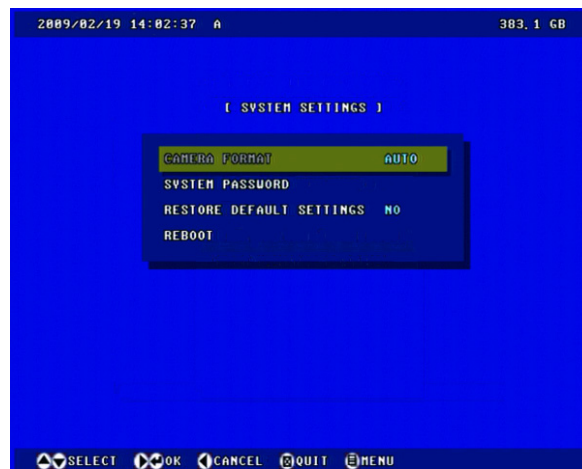

Figure 4-47

- **CAMERA FORMAT:** Select the video format to be **NTSC** or **PAL**; or select **AUTO** for automatic detection.
- **SYSTEM PASSWORD:** Set up the system password. Once the password is set up, you will be prompted for a password when you enter the main menu.
- **RESTORE DEFAULT SETTINGS:** Return the system to default settings.
- **REBOOT:** Restart the system.

To schedule the GV-Compact DVR V3 to automatically restart at a specified time, see 6.8.6 *Tools* of the Web-based configuration.

### 4.8.8 System Log

You can view and save the system events logged on the GV-Compact DVR V3. To back up the system log, press the **REC** button on the Remote Control, and select USB or DVD disc to store the backup data.

The GV-Compact DVR V3 models GV- LX4C3D2W and GV-LX8CD2W are equipped with a DVD-RW drive for easy data backup. You can also connect a DVD-RW writer or USB storage device to the unit for data backup.

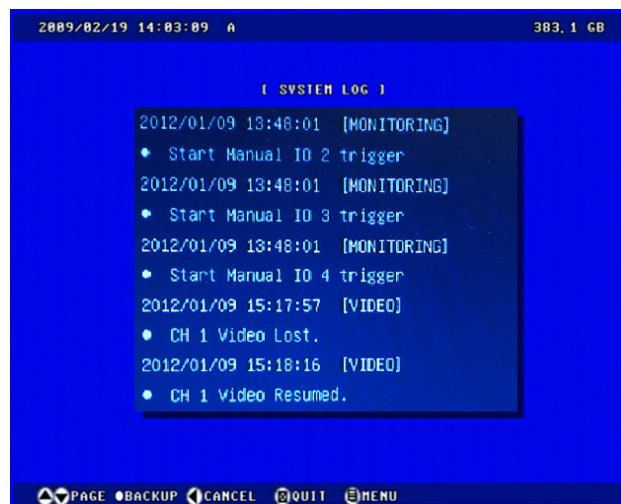

Figure 4-48

## 4.8.9 Backup

You can back up video files of the specified time and channels to a USB storage device or DVD disc.

The GV-Compact DVR V3 models **GV-LX4C3D2W** and **GV-LX8CD2W** are equipped with a DVD-RW drive for easy file backup. You can also connect a DVD-RW writer or USB storage device to the unit for file backup.

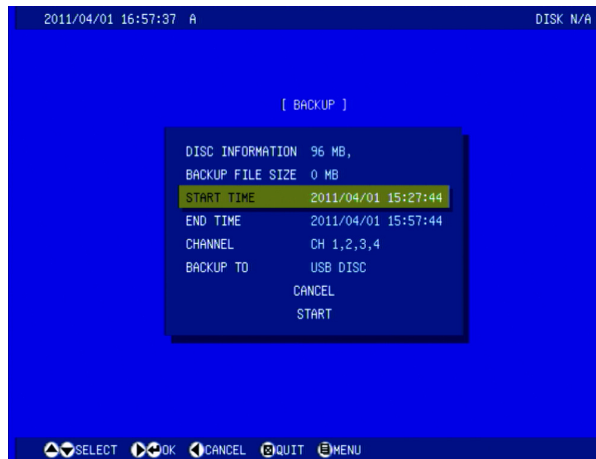

Figure 4-49

To play back the backup files, see [7.2.4 Playback of Backup Files](#).

---

### Note:

1. The GV-Compact DVR V3 only supports the FAT file system. Before connecting the USB storage device, make sure it is FAT formatted.
  2. The CD-R and CD-RW backup are not supported.
  3. The time for different USB storage devices to be recognized may vary.
-

## Chapter 5 Remote Viewing Using A Web Browser

Not only can the GV-Compact DVR V3 operate as a standalone, but also a networked device. Using the Internet Explorer, you can remotely access and manage the GV-Compact DVR V3.

### 5.1 Assigning an IP Address

Designed for use on an Ethernet network, the GV-Compact DVR V3 must be assigned an IP address to make it accessible. By default, the IP address of your GV-Compact DVR V3 is assigned by the DHCP server unless your router does not support DHCP. In this case, the default IP address will be **192.168.0.10**. However, there are two ways to assign an IP address to the unit: Using OSD Menu and Connecting with a PC.

#### 5.1.1 Using OSD Menu

Use the connection settings in the OSD menu to assign a static IP, and connect the GV-Compact DVR V3 to the Internet for remote operation.

1. Press the **Menu** button, select **NETWORK** and then select **CONNECTION SETTINGS**. Set up a static IP, subnet mask, gateway, primary DNS and secondary DNS (optional).

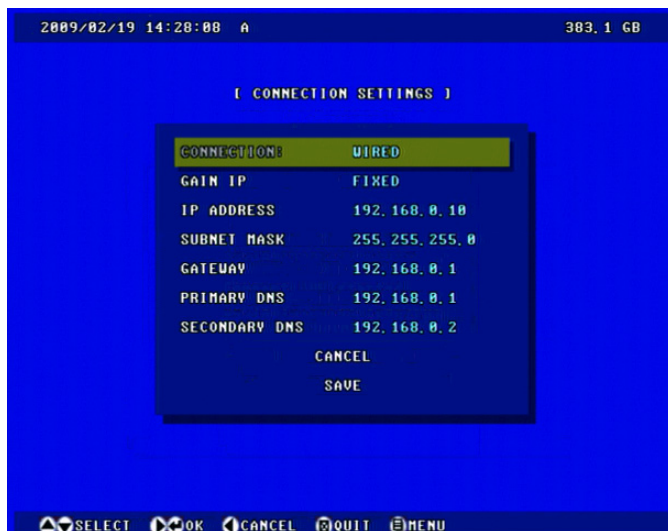

Figure 5-1

2. Using the network cable, connect one end to the LAN port on the rear panel of the unit, and the other end to the network. The GV-Compact DVR V3 is now accessible by entering the assigned IP on the browser.

## 5.1.2 Connecting with a PC

Use a computer on the same LAN with the GV-Compact DVR V3 to check and assign the IP address.

### 5.1.2.1 Checking the IP Address

Follow the steps below to look up the IP address and access the Web interface.

1. Install the GV-IP Device Utility program included on the Software CD/DVD.

---

**Note:** The PC installed with GV-IP Device Utility must be under the same LAN with the GV-Compact DVR V3 you wish to configure.

---

2. On the GV-IP Utility window, click the  button to search for the IP devices connected in the same LAN. Click the **Name** or **Mac Address** column to sort.

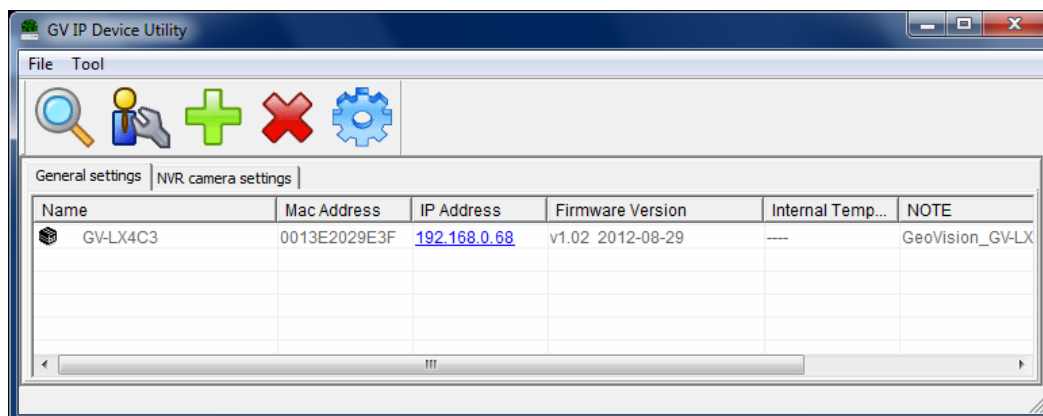

Figure 5-2

3. Find the unit with its Mac Address to see the IP address.
4. To login, type the IP address in your web browser. A login dialog box appears.
5. Type the default username and password **admin**.
6. Click **OK** to access the Web interface.

### 5.1.2.2 Changing the IP Address

To assign a static IP address or establish a connection to your ISP, log in the Web interface to access the network setting page.

---

**Note:** If your router does not support DHCP, the default IP address will be **192.168.0.10**. In this case, it is strongly suggested to modify the IP address to avoid the IP address conflict with other GeoVision IP devices on the same LAN.

---

1. Using the network cable, connect one end to the LAN port on the rear panel of the unit, and the other end to a hub or a switch on the LAN.
2. Open the browser on the computer, and type the assigned dynamic IP address or default IP address of the GV-Compact DVR V3.
3. In both Login and Password fields, type the default value **admin**. Click **Apply**.
4. In the left menu, select **Network** and then **LAN** to begin the network settings.

The screenshot displays the 'LAN Configuration' web interface. At the top, it states 'In this section you can configure GV-Compact DVR to work inside of LAN.' Below this, there are three main sections: 'Optional Network type', 'LAN Configuration', and 'Wireless Settings'.  
1. 'Optional Network type': Contains two radio buttons. 'Wired Ethernet' is selected with the text 'Select this option to use wired 10/100Mbps ethernet'. 'Wireless' is unselected with the text 'Select this option to use Wireless'.  
2. 'LAN Configuration': Contains three radio buttons. 'Dynamic IP address' is unselected with the text 'Select this option to obtain IP address from a DHCP server' and a 'Test DHCP' button. 'Static IP address' is selected with the text 'Select this option to enter a Static IP address manually'. Below this are input fields for: IP Address (192.168.0.10), Subnet Mask (255.255.255.0), Router/Gateway (192.168.0.1), Primary DNS (192.168.0.1), and Secondary DNS (192.168.0.2) with '(Optional)' next to it. The 'PPPoE' option is unselected with the text 'Select this option to establish a DSL connection'. Below it are 'Username:' and 'Password:' input fields.  
3. 'Wireless Settings': Contains three radio buttons. 'Dynamic IP address' is unselected with the text 'Select this option to obtain IP address from a DHCP server' and a 'Test DHCP' button. 'Static IP address' is selected with the text 'Select this option to enter a Static IP address manually'. Below this are input fields for: IP Address (192.168.100.10), Subnet Mask (255.255.255.0), Router/Gateway (192.168.0.1), Primary DNS (192.168.0.1), and Secondary DNS (192.168.0.2) with '(Optional)' next to it.  
At the bottom left of the form is an 'Apply' button.

Figure 5-3

5. To assign a static IP address, select **Static IP address**. Type IP Address, Subnet Mask, Router/Gateway, Primary DNS and Secondary DNS.
6. To establish a connection to your ISP, select **Use PPPoE**, and type the username and password.
7. Click **Apply**. The GV-Compact DVR V3 is now accessible by entering the assigned IP address on the browser.

For details, see *6.7.1 LAN*.

---

**IMPORTANT:**

1. **PPPoE** should only be enabled if you know which IP address the GV-Compact DVR V3 will get from the ISP. Otherwise, you must use the Dynamic DNS service to obtain a domain name linked to the GV-Compact DVR V3's changing IP address first. For details on Dynamic DNS Server settings, see *6.7.3 Advanced TCP/IP*.
  2. If **PPPoE** is enabled and you cannot access the unit, you may have to reset it to the factory default settings and then perform the network settings again. To restore the factory settings, see the **Reset** button in *2.1 Front Panel*.
-

### 5.2 Accessing Your Surveillance Images

Once installed, the GV-Compact DVR V3 is accessible on a network. Follow these steps to access your surveillance images:

1. Start the Internet Explorer browser.
2. Enter the IP address or the domain name of the GV-Compact DVR V3 in the **Location/Address** field of your browser.

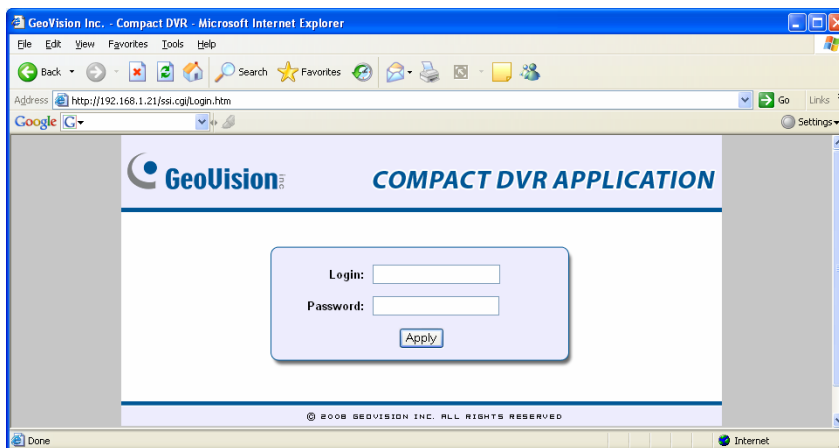

Figure 5-4

3. Enter the login name and password.
  - The default login name and password for Administrator are **admin**.
  - The default login name and password for Guest are **guest**.
4. Click **Apply**. A video image, similar to the example on Figure 5-5, is now displayed in your browser.

---

**Note:** To enable the updating of images in Internet Explorer, you must set your browser to allow ActiveX Controls and perform a once-only installation of GeoVision's ActiveX component onto your computer.

---



## 5.3 Functions Featured on the Main Page

Two types of users are allowed to log in the GV-Compact DVR V3: Administrator and Guest. The Administrator has unrestricted access to all system configurations, while the Guest has the access to live view and network status only. This section introduces the live view functions and the network status on the main page, which can be accessed by both Administrator and Guest.

### Main Page of Guest Mode

- ▼ Video and Motion
  - ▼ Live View
    - ▶ Camera 1
    - ▶ Camera 2
    - ▶ Camera 3
    - ▶ Camera 4
    - ▶ 4 Cameras
  - ▼ Network
    - ▶ Status

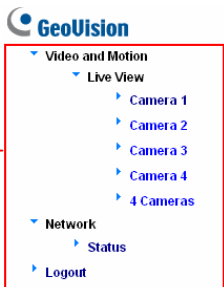

**Live View**

Live View Configuration

In this section you can see and configure the default camera view.

08:04:47    Play



▶
■
🔊
📄
📷

Figure 5-5 Guest mode of the 4-channel unit

### 5.3.1 The Live View Window

#### Live View

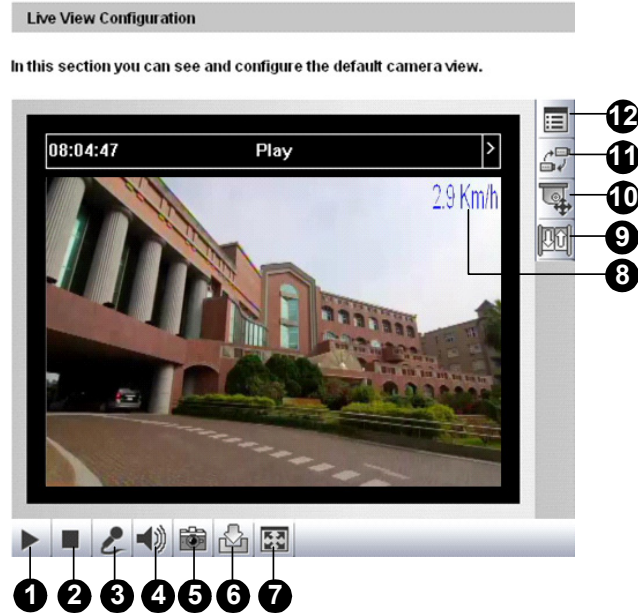

Figure 5-6

No.	Name	Function
1	Play	Plays live video.
2	Stop	Stop playing video.
3	Microphone	Talks to the surveillance area from the local computer.
4	Speaker	Listens to the audio around the camera.
5	Snapshot	Takes a snapshot of live video. --- See section 5.3.3.
6	File Save	Records live video to the local computer. --- See section 5.3.4.
7	Full Screen	Switches to full screen view. Right-click the image to have these options: <b>Snapshot, PIP, PAP, Zoom In</b> and <b>Zoom Out</b> . --- See section 5.3.5 for PIP and PAP Views.
8	Vehicle Speed	Displays the vehicle speed. --- See section 6.2.3 for GPS settings.
9	I/O Control	Starts the I/O Control Panel and the Visual Automation. --- See section 5.3.13 and 5.3.14.
10	PTZ Control	Starts the PTZ Control Panel and the Visual PTZ. --- See section 5.3.11 and 5.3.12.
11	Change Camera	Sets the desired camera for display.
12	Show System Menu	Brings up these functions: <b>Alarm Notify, Video and Audio Configuration, Remote Config, Show Camera Name</b> and <b>Image Enhance</b> . --- See section 5.3.6, 5.3.7, 5.3.8, 5.3.9 and 5.3.10 respectively.

### 5.3.2 The Control Panel of the Live View Window

To open the control panel of the Live View window, click the arrow button on top of the window. You can access the following functions by using the right and left arrow buttons on the control panel.

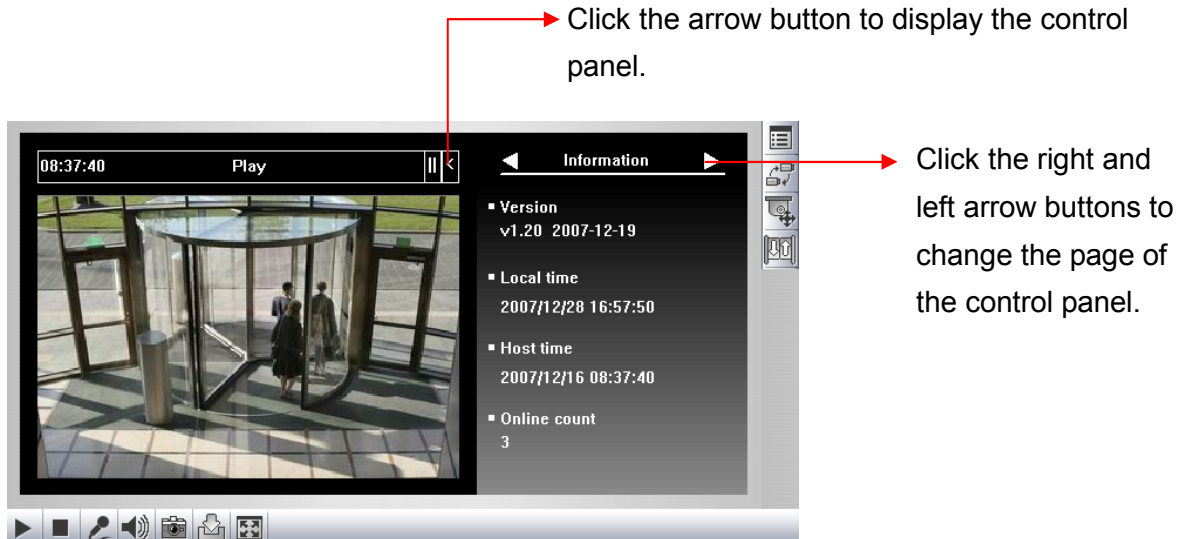

Figure 5-7

**[Information]** Displays the version of the GV-Compact DVR V3, local time of the local computer, host time of the GV-Compact DVR V3, and the number of users logging in to the GV-Compact DVR V3.

**[Video]** Displays the current video codec, resolution and data rate.

**[Audio]** Displays the audio data rates when the microphone and speaker devices are enabled.

**[I/O Control]** Provides a real-time graphic display of the input and output status. You can force the output to be triggered by double-clicking its icon.

**[Alarm Notify]** Displays the captured images by sensor triggers and/or motion detection. For this function to work, you must configure the Alarm Notify settings first. See 5.3.6 *Alarm Notification*.

**[Camera Adjustment]** Allows you to adjust the image quality.

**[GPS]** The GPS function is only supported on Anti-Vibration ACC models (GV-LX4C3V / GV-LX8CV1 / GV-LX8CV2). For details see 8.3 *GPS Tracking*.

**[Download]** Allows you to install the programs from the hard drive.

### 5.3.3 Snapshot of a Live Video

To take a snapshot of live video, follow these steps:

1. Click the **Snapshot** button (No. 5, Figure 5-6). The Save As dialog box appears.
2. Specify **Save in**, type the **File name**, and select **JPEG** or **BMP** as **Save as Type**. You may also choose whether to display the name and date stamps on the image.
3. Click the **Save** button to save the image in the local computer.

### 5.3.4 Video Recording

You can record live video for a certain period of time to your local computer.

1. Click the **File Save** button (No. 6, Figure 5-6). The Save As dialog box appears.
2. Specify **Save in**, type the **File name**, and move the **Time Period** scroll bar to specify the time length of the video clip from 1 to 5 minutes.
3. Click the **Save** button to start recording.
4. To stop recording, click the **Stop** button (No. 2, Figure 5-6).

### 5.3.5 Picture-in-Picture and Picture-and-Picture View

The full screen mode provides two types of close-up views: **Picture-in-Picture (PIP)** and **Picture-and Picture (PAP)**. The two views are useful to provide clear and detailed images of the surveillance area.

#### Picture-in-Picture View

With the Picture in Picture (PIP) view, you can crop the video to get a close-up view or zoom in on the video.



Figure 5-8

1. Right-click the live view and select **PIP**. An inset window appears.
2. Click the insert window. A navigation box appears.
3. Move the navigation box around in the inset window to have a close-up view of the selected area.
4. To adjust the navigation box size, move the cursor to any of the box corners, and enlarge or diminish the box.
5. To exit the PIP view, right-click the image and click **PIP** again.

### Picture-and-Picture View

With the Picture and Picture (PAP) view, you can create a split video effect with multiple close-up views on the image. A total of 7 close-up views can be defined.



Figure 5-9

1. Right-click the live view and select **PAP**. A row of three inset windows appears at the bottom.
2. Draw a navigation box on the image, and this selected area is immediately reflected in one inset window. Up to seven navigation boxes can be drawn on the image.
3. To adjust a navigation box size, move the cursor to any of the box corners, and enlarge or diminish the box.
4. To move a navigation box to another area on the image, drag it to that area.
5. To change the frame color of the navigation box or hide the box, right-click the image, select **Mega Pixel Setting** and select one of these options:
  - **Display Focus Area of PAP Mode:** Displays or hides the navigation boxes on the image
  - **Set Color of Focus Area:** Changes the color of the box frames.
6. To delete a navigation box, right-click the desired box, select **Focus Area of PAP Mode** and click **Delete**.
7. To exit the PAP view, right-click the image and click **PAP** again.

### 5.3.6 Alarm Notification

After input triggers and motion detection, you can be alerted by a pop-up live video and view up to four captured images.



Figure 5-10

To configure this function, click the **Show System Menu** button (No. 12, Figure 5-6), and select **Alarm Notify**. This dialog box appears.

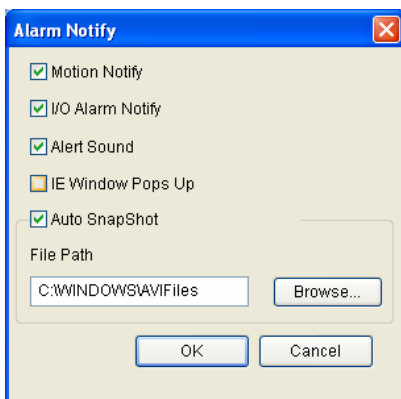

Figure 5-11

- **Motion Notify:** Once motion is detected, the captured images are displayed on the control panel of the Live View window.
- **I/O Alarm Notify:** Once the input device is triggered, the captured images are displayed on the control panel of the Live View window. For this function to work, the Administrator needs to install the input device properly. See 6.2.1 I/O Control.
- **Alert Sound:** Activate the computer alarm on motion and input triggered detection.
- **IE Window Pops up:** The minimized Live View window pops up on motion and input-triggered detection.
- **Auto Snapshot:** The snapshot of live video is taken every 5 seconds on motion and input triggered detection.
- **File Path:** Assign a file path to save the snapshots.

### 5.3.7 Video and Audio Configuration

You can enable the microphone and speaker for two-way audio communication and adjust the audio volume. To change audio configuration, click the **Show System Menu** button (No. 12, Figure 5-6), and select the **Audio Configure** tab.

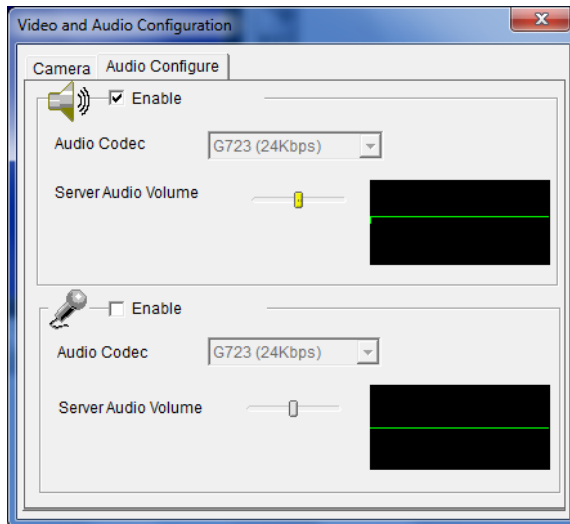

Figure 5-12

### 5.3.8 Remote Configuration

You can view the connection status of the central monitoring stations and upgrade firmware over the network. Click the **Show System Menu** button (No. 12, Figure 5-6), and select **Remote Config**. The Remote Config dialog box will appear.

**[Status]** In this tab, you can see the current status of the connection to Center V2 and VSM.

**[Firmware Upgrade]** In this tab, you can upgrade the firmware over the network. For details, see *Chapter 8 Advanced Applications*.

### 5.3.9 Camera Name Display

To display the camera name on the image, click the **Show System Menu** button (No. 12, Figure 5-6), and select **Show Camera Name**.



### 5.3.10 Image Enhancement

To enhance the image quality of live video, click the **Show System Menu** button (No. 12, Figure 5-6), and select **Image Enhance**. This dialog box appears.

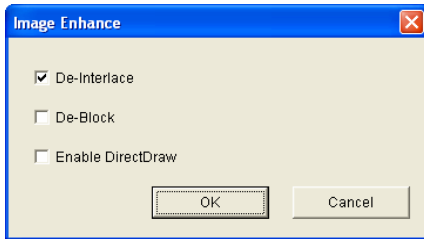

Figure 5-13

- **De-Interlace:** Converts the interlaced video into non-interlaced video.
- **De-Block:** Removes the block-like artifacts from low-quality and highly compressed video.
- **Enable DirectDraw:** Activates the DirectDraw function.

### 5.3.11 PTZ Control

To open the PTZ control panel, click the **PTZ Control** button (No. 10, Figure 5-6) and select **PTZ Control Panel**. The features included in the **Option** button may vary depended on different PTZ devices.

This feature is only available when the PTZ is set ahead by the Administrator. For details, see [6.2.2 PTZ Settings](#).

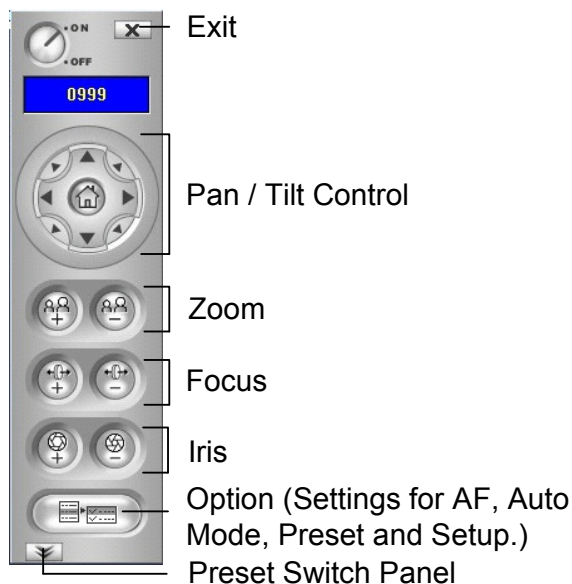

Figure 5-14

### 5.3.12 Visual PTZ

In addition to the PTZ control panel, you can display a visual PTZ control panel on the image. This feature is only available when the PTZ is set ahead by the Administrator. For details, see *6.2.2 PTZ Settings*.



Figure 5-15

- To access this feature, click the **PTZ Control** button (No. 10, Figure 5-6) and select **Visual PTZ**.
- To change the panel settings, click the green **PTZ** button on the top left corner. You will have these options:

#### [PTZ Control Type]

- **Type 1:** In this mode when you place the mouse arrow on the four directions, i.e. north, south, east, west, the speed indicator of five levels will appear. Click and hold on the required level of movement and the camera will move as per the specific speed.
- **Type 2:** In this mode with the mouse click, the PTZ control panel will appear. The movement of the camera will depend on the speed of the mouse movement.

#### [Configure]

- **Set Color:** Changes the color of the panel. Three kinds of colors are available: **Red**, **Green** and **Blue**.
- **Transparent Degree:** Adjusts the transparency level of the panel. Ten levels range from 10% (fully transparent) to 100% (fully opaque).

### 5.3.13 I/O Control

The I/O Control window provides real-time graphic displays of camera and I/O status, and alarm events. Additionally, you can force output to be triggered.

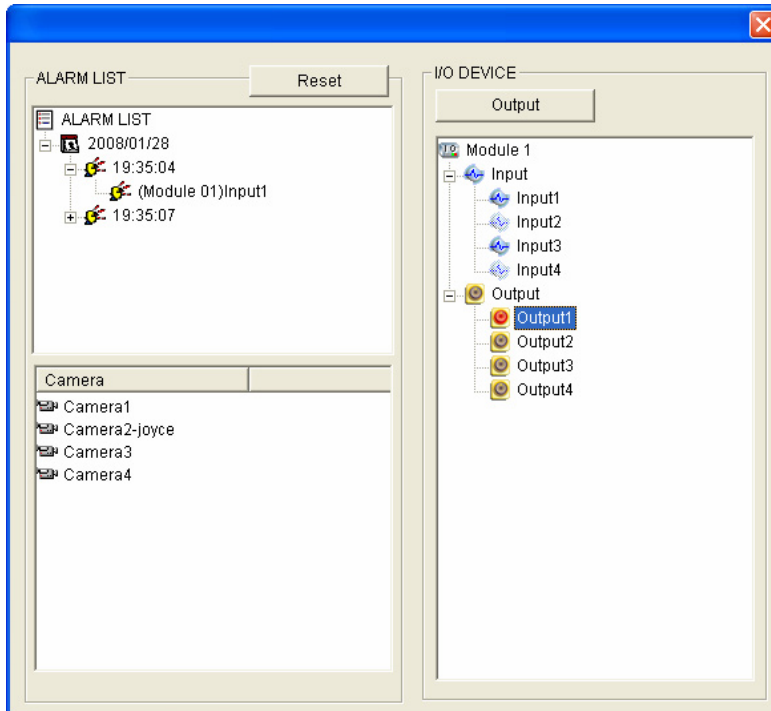

Figure 5-16

- To display the I/O control window, click the **I/O Control** button (No. 9, Figure 5-6).
- The Alarm List is displayed in three levels. The first level indicates date, the second indicates time, and the third indicates alarm ID. Clicking the **Reset** button will clear the list.
- To trigger an output device, highlight an output and then click the **Output** button.

### 5.3.14 Visual Automation

The Visual Automation allows you to change the current state of the electronic device by simply clicking on its image, e.g. turning the light ON. This feature is only available when the Visual Automation is set ahead by the Administrator. For details, see 6.1.4 *Visual Automation*.

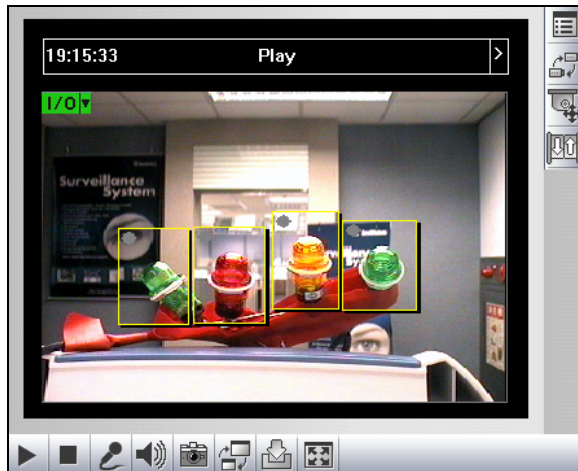

Figure 5-17

- To access this feature, click the **I/O Control** button (No. 9, Figure 5-6) and select **Visual Automation**.
- To change the style of the set areas, click the green **I/O** button on the top left corner. You will have these options:
  - **Show All:** Displays all set areas.
  - **Rec Float:** Embosses all set areas.
  - **Set Color:** Changes the frame color of all set areas

### 5.3.15 Multicast

Note this function is only available on **the four-channel GV-Compact DVR V3**.

The Multicast view allows the GV-Compact DVR V3 receiving video and audio streams from a multicast group. It also enables the unit to receive audio broadcast from the hosts in the multicast group.

To join a multicast group and listen to audio broadcasting, it is required to activate the related settings in *6.7.5 Multicast*.

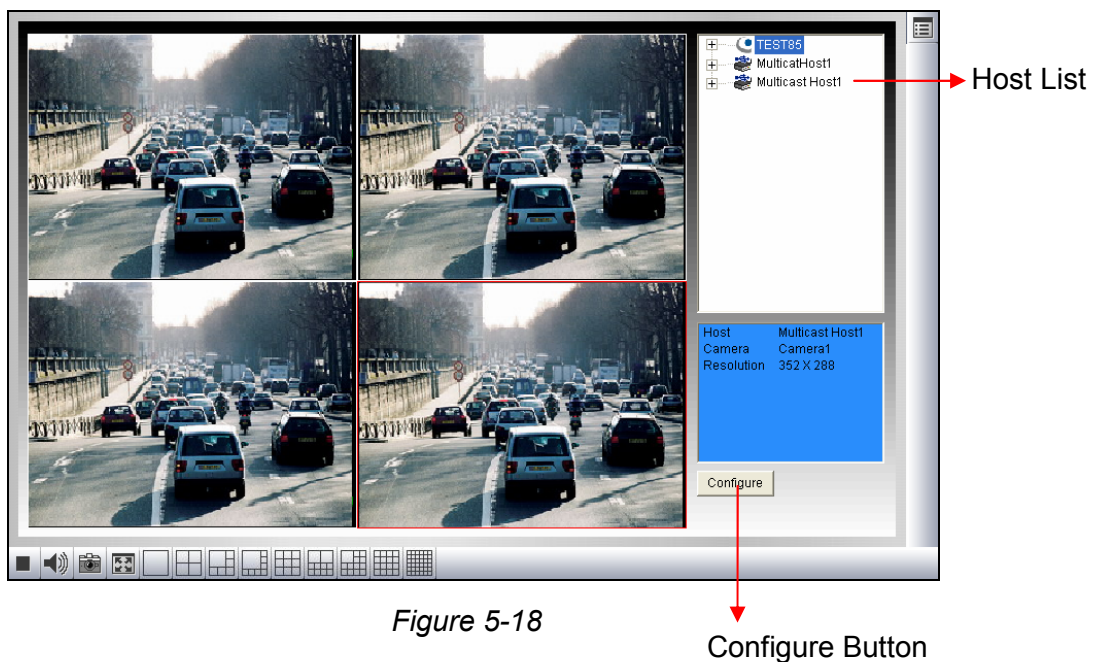

Figure 5-18

Configure Button

1. The host(s), in the multicast group, is displayed automatically on the host list. If you cannot see any host displayed, click the **Configure** button, select **General Setup**, select **Multicast** and ensure the relevant IP address, port number and network card are correctly configured.
2. Expand the Host folder and drag the desired cameras to the screen for display. If the host has already set a password, you will be promoted to enter it at this step.
3. To receive audio broadcasting, first ensure a speaker is properly installed on the local computer. Then click the **Configure** button, select **General Setup**, select **Receive broadcast audio**, and ensure the broadcast IP address and port number are correctly configured.
4. To save the current settings of screen division and camera display for future use, click the **Configure** button, select **Video List Setup**, and select **Export**. You can also select **Import** to apply the pre-defined settings.

### 5.3.16 Network Status

To view the network status, in the left menu, click **Network** and select **Status**.

<b>Network Status Information</b>	
<b>Current Status Information</b>	
<b>In this section you can see an overview of device status.</b>	
interface:	Wired
IP Acquirement:	Fixed
MAC Address:	0013E201233A
IP Address:	192.168.1.21
Subnet Mask:	255.255.254.0
Gateway:	192.168.0.1
Domain Name Server 1:	168.95.192.1
Domain Name Server 2:	168.95.1.1

*Figure 5-19*

## Chapter 6 Remote Configurations

The Administrator can remotely configure the GV-Compact DVR V3 via the network. Eight categories of configurations are involved in the system configuration: **Video and Motion**, **Digital I/O and PTZ**, **Events and Alerts**, **Monitoring**, **Recording Schedule**, **Remote ViewLog**, **Network**, and **Management**.

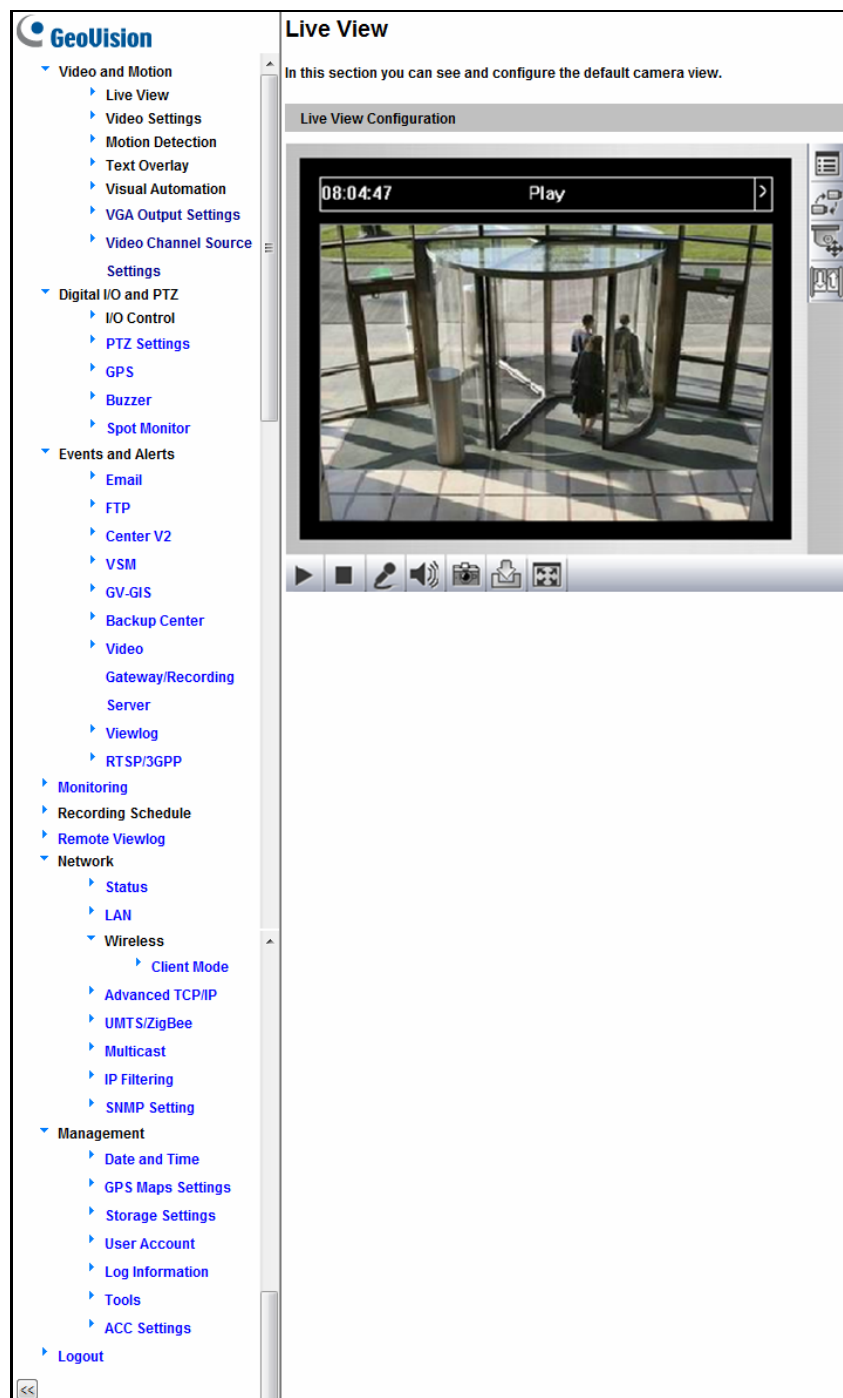

Figure 6-1

**List of Menu Options**

Find the topic of interest by referring to the section number prefixed to each option.

6.1 Video and Motion	<ul style="list-style-type: none"> <li>6.1.1 Video Settings</li> <li>6.1.2 Motion Detection</li> <li>6.1.3 Text Overlay</li> <li>6.1.4 Visual Automation</li> <li>6.1.5 VGA Output Settings</li> <li>6.1.6 Video Channel Source Settings</li> </ul>
6.2 Digital I/O and PTZ	<ul style="list-style-type: none"> <li>6.2.1 I/O Control</li> <li>6.2.2 PTZ Settings</li> <li>6.2.3 GPS</li> <li>6.2.4 Buzzer</li> <li>6.2.5 Spot Monitor</li> </ul>
6.3 Events and Alerts	<ul style="list-style-type: none"> <li>6.3.1 Email</li> <li>6.3.2 FTP</li> <li>6.3.3 Center V2</li> <li>6.3.4 VSM</li> <li>6.3.5 GV-GIS</li> <li>6.3.6 Backup Center</li> <li>6.3.7 Video Gateway / Recording Server</li> <li>6.3.8 ViewLog</li> <li>6.3.9 RTSP / 3GPP</li> </ul>
6.4 Monitoring	
6.5 Recording Schedule	<ul style="list-style-type: none"> <li>6.5.1 Recording Schedule Settings</li> <li>6.5.2 I/O Monitoring Settings</li> </ul>
6.6 Remote Viewlog	
6.7 Network	<ul style="list-style-type: none"> <li>6.7.1 LAN</li> <li>6.7.2 Wireless-Client Mode</li> <li>6.7.3 Advanced TCP/IP</li> <li>6.7.4 UMTS / ZigBee</li> <li>6.7.5 Multicast</li> <li>6.7.6 IP Filtering</li> <li>6.7.7 SNMP Setting</li> </ul>
6.8 Management	<ul style="list-style-type: none"> <li>6.8.1 Date and Time Settings</li> <li>6.8.2 GPS Maps Settings</li> <li>6.8.3 Storage Settings</li> <li>6.8.4 User Account</li> <li>6.8.5 Log Information</li> <li>6.8.6 Tools</li> <li>6.8.7 ACC Settings</li> </ul>



## **6.1 Video & Motion**

This section includes the video image settings and how the images can be managed by using Video Settings, Motion Detection, Text Overlay, Visual Automation and Video Channel Source Settings.

### **6.1.1 Video Settings**

The Video Settings section allows you to configure the video source, resolution and the related options for the video stream.

For each channel, the video stream is set to H.264 codec and can be configured up to 704 x 480 (for both four-channel and eight-channel models) in resolution.

### Video Settings

In this section you can define compression art, broadcasting method and privacy mask.

---

**Name**

Name

---

**Video Signal Type**

In this section you can configure camera's video signal between NTSC or PAL, also the resolution and frame per second to be transmitted through the network

Auto detect signal type on booting

	Signal Format	Resolution	Frame per second
<input checked="" type="radio"/>	NTSC	704*480	30
<input type="radio"/>	PAL	352*288	25

---

**Bandwidth Management**

In this section you can configure the bit rate used by MPEG-4 video stream. Using VBR (Variable Bit Rate) is an intelligent method to compensate between image quality and bandwidth control. But if you want to provide consistently the same image quality at bandwidth cost, please set to CBR (Constant Bit Rate).

<input checked="" type="radio"/>	VBR	Quality <input type="text" value="Good"/>
<input type="radio"/>	CBR	Maximal Bit Rate <input type="text" value="3072 Kbps"/>

---

**GOP Structure and Length**

In this section you can configure the composition of the MPEG-4 video stream (GOP structure). By using I-Frame only will increase video quality dramatically but also the bandwidth.

Group of Picture(GOP)  (1 indicates to generate I-VOP only and disable motion detection)  
Size

---

**RecordSettings**

In this section you can configure pre-alarm and post-alarm settings.

Pre-alarm recording time  seconds

Post-alarm recording time  seconds with hard disk installed (1~30)

Split interval  minutes

Record audio

---

**Text OverlaySettings**

In this section you can set up Text Overlay

Overlaid with camera name

Overlaid with date stamps

Overlaid with time stamps

Overlaid with the GPS speed  km/h  mile/h

Overlay with digital input description name  Input 1  Input 2  Input 3  Input 4

---

**Watermark Setting**

In this section you can set Watermark function.

Enable

---

**Apply All Settings**

In this section you can apply the settings to all cameras

Apply the settings to all cameras

Figure 6-2

**[Name]**

Rename the camera. To display the camera name on the image, see 5.3.9 *Camera Name Display*.

**[Video Signal Type]**

- **Auto detect signal type on booting:** Automatically detects the type of video input is NTSC or PAL.

There are different options of the image resolutions for video stream.

	NTSC	PAL
<b>Main Stream</b>	704 x 480	704 x 576
	704 x 480 De-interlaced (704 x 240)	704 x 576 De-interlaced (704 x 288)
	352 x 240	352 x 288

There are several frame rates available.

	Frame Rate
<b>NTSC</b>	2, 3, 5, 7.5, 10, 15, 30 (Default)
<b>PAL</b>	2.5, 5, 8, 12.5, 25 (Default)

---

**Note:** For the eight-channel models, with 704 x 480 / 704 x 576 resolution, the frame rate for recording and live view will be 15 fps/ch (NTSC) or 12.5 fps/ch (PAL).

---

**[Bandwidth Management]**

It is possible to control the bitrate, which in turn allows the amount of bandwidth usage to be controlled.

- **VBR (Variable Bitrate):** The quality of the video stream is kept as constant as possible at the cost of a varying bitrate. The bandwidth is much more efficiently used than a comparable CBR. Set the image quality to one of the 5 standards: **Poor**, **Fair**, **Good**, **Great** and **Excellent**.
- **CBR (Constant Bitrate):** CBR is used to achieve a specific bitrate by varying the quality of the stream. The bitrates available for selection depend on the image resolution.

**[GOP Structure and Length]** Set the maximum number of frames between every key frame.

The limit is 1 key frame for every 120 frames.

**[Record Settings]**

The record settings allow you to capture images before and/or after a motion and an I/O event happens.

- **Pre-alarm recording time:** Activates video recording before an event occurs. Set the recording time to 1 or 2 seconds.
- **Post-alarm recording time:** Activates video recording after an event occurs. Set the recording time from 1 to 30 seconds.
- **Split Interval:** Sets the time length between each event file.
- **Record Audio:** Activates audio recording when an event occurs.

**[Text Overlay Settings]**

The settings allow you to display the related names and information on live view and recorded files.

- **Overlaid with camera name:** Includes camera names in live and recorded videos.
- **Overlaid with date stamps:** Includes date stamps in live and recorded videos.
- **Overlaid with time stamps:** Includes time stamps in live and recorded videos.
- **Overlaid with the GPS data:** Includes the vehicle speed in live and recorded videos. This function is only supported on Anti-Vibration ACC models (GV-LX4C3V / GV-LX8CV1 / GV-LX8CV2).
- **Overlaid with digital input description name:** Includes the names of the selected inputs on live and recorded videos.

**[Watermark Setting]**

- **Enable:** Enable this option to watermark all recordings. The watermark allows you to verify whether the video has been tampered while it was recorded and saved. See [8.5 Verifying Watermark](#).

**[Apply All Settings]**

- **Apply the settings to all cameras:** Applies the same settings to other cameras.

## 6.1.2 Motion Detection

Motion detection is used to generate an alarm whenever movement occurs in the video image. You can configure up to 8 areas with different sensitivity values for motion detection.

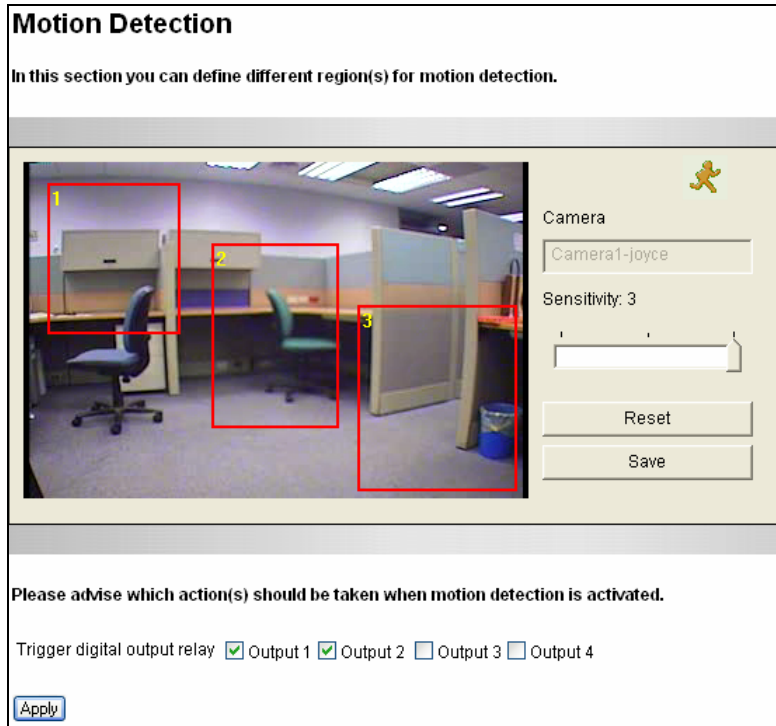

Figure 6-3

1. The default sensitivity value is 2 for the whole area. To define a different sensitivity value, click **Reset**.
2. Select the desired sensitivity by moving the slide bar. There are three values. The higher the value, the more sensitive the camera is to motion.
3. Drag an area on the image. Click **Add** when you are prompted to confirm the setting.
4. To create several areas with different sensitivity values, repeat Steps 2 and 3.
5. Click **Save** to save the above settings.
6. If you want to trigger the alarm outputs when motion is detected, select the outputs (Output 1 to Output 4) and click the **Apply** button. To activate the output settings, you must also start **Input** monitoring manually or by schedule. For related settings, see 6.4 *Monitoring* and 6.5.2 *I/O Monitoring Settings*.

### 6.1.3 Text Overlay

The Text Overlay function allows you to type any text in any place on the camera view. Up to 16 text messages can be created. The overlaid text will also be saved in the recorded images.

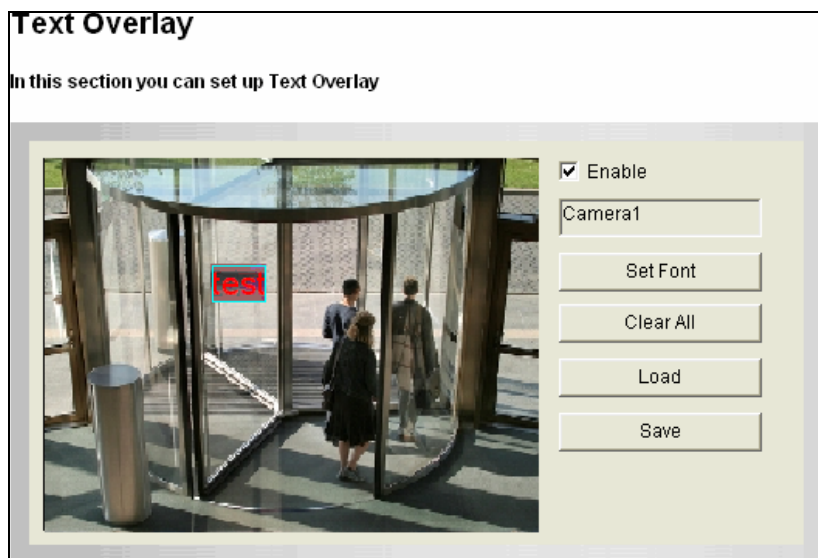

Figure 6-4

1. Select the **Enable** option.
2. Click any place on the image. This dialog box appears.

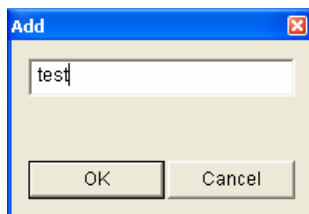

Figure 6-5

3. Type the desired text, and click **OK**. The text is overlaid on the image.
4. Click on the text and drag it to any place on the image.
5. Click **Set Font** to modify the font style of the text.
6. Click **Save** to apply the settings, or click **Load** (Undo) to revert to a previous setting.

## 6.1.4 Visual Automation

Note for **eight-channel GV-Compact DVR V3**, this function can only be applied to channel 1 to 4.

This intuitive feature helps you automate any electronic device by triggering the connected output device. When you click on the image of the electronic device, you can simply change its current state, e.g. light ON.

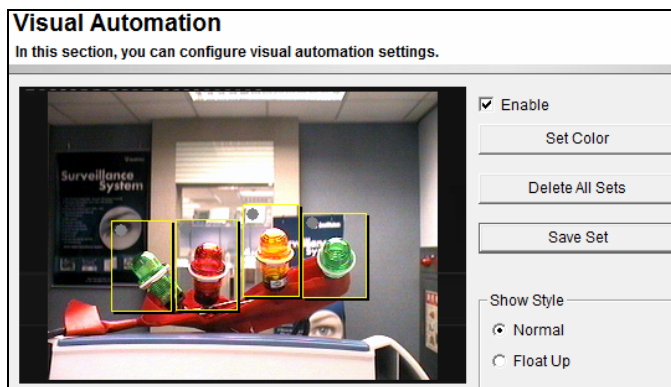

Figure 6-6

1. Select the **Enable** option.
2. Drag an area on the image of the desired electronic device. This dialog box appears.

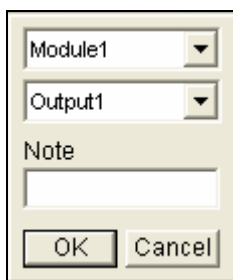

Figure 6-7

3. Assign the connected module and output device. In the Note field, type a note to help you manage the device. Click **OK** to save the settings.
4. To change the frame color of the set area, click the **Set Color** button.
5. To emboss the set area, select **Float Up**; or keep it flat by selecting **Normal**.
6. Click the **Save Set** button to apply the settings.

To perform the function, see *5.3.14 Visual Automation*.

### 6.1.5 VGA Output Settings

The GV-Compact DVR V3 is equipped with a VGA connector for computer monitors or high-definition television sets. You can select the screen resolution for the VGA output.

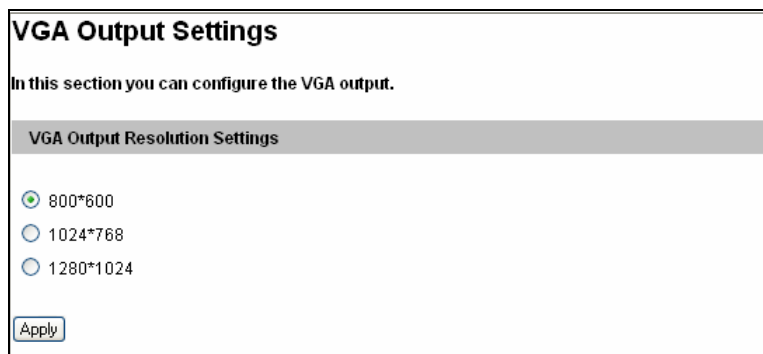

The screenshot shows a web-based configuration window titled "VGA Output Settings". Below the title is a descriptive sentence: "In this section you can configure the VGA output." A grey header bar contains the text "VGA Output Resolution Settings". Below this, there are three radio button options for resolution: "800\*600" (which is selected), "1024\*768", and "1280\*1024". At the bottom left of the window is an "Apply" button.

Figure 6-8

### 6.1.6 Video Channel Source Settings

Note this function is only available for the **four-channel GV-Compact DVR V3**.

The settings allow you to assign the video input to the desired video channel for display.

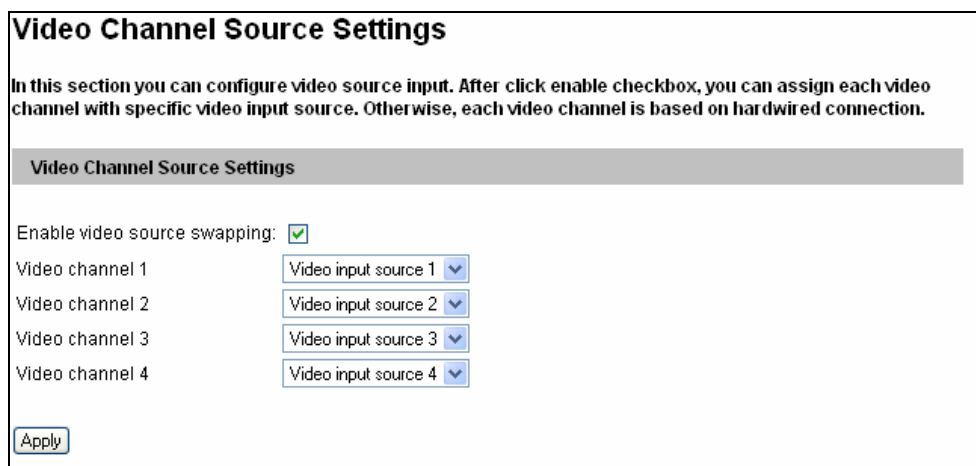

The screenshot shows a web-based configuration window titled "Video Channel Source Settings". Below the title is a descriptive sentence: "In this section you can configure video source input. After click enable checkbox, you can assign each video channel with specific video input source. Otherwise, each video channel is based on hardwired connection." A grey header bar contains the text "Video Channel Source Settings". Below this, there is a checkbox labeled "Enable video source swapping:" which is checked. Underneath, there are four rows, each representing a video channel. Each row has a label "Video channel 1" through "Video channel 4" and a corresponding dropdown menu labeled "Video input source 1" through "Video input source 4". At the bottom left of the window is an "Apply" button.

Figure 6-9



## 6.2 Digital I/O & PTZ

The I/O terminal block, on the rear panel of the GV-Compact DVR V3, provides the interface for the following applications:

1. Alarm input and output
2. RS-485 interface for PTZ control

### 6.2.1 I/O Control

#### Input Setting

The four-channel Compact DVR V3 can connect up to 4 input devices, such as sensors, while the eight-channel unit can connect up to 8 input devices.

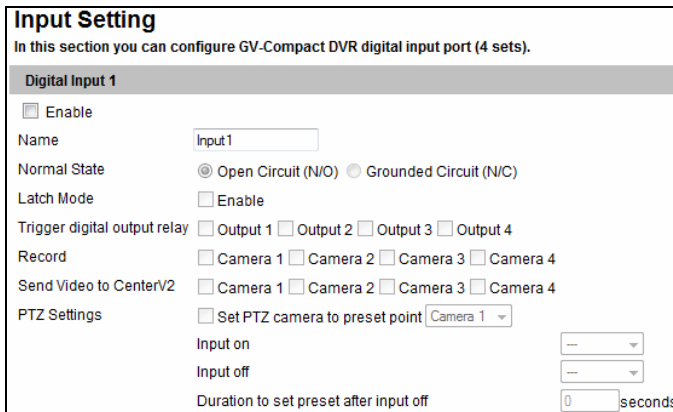

**Input Setting**  
In this section you can configure GV-Compact DVR digital input port (4 sets).

**Digital Input 1**

Enable

Name:

Normal State:  Open Circuit (N/O)  Grounded Circuit (N/C)

Latch Mode:  Enable

Trigger digital output relay:  Output 1  Output 2  Output 3  Output 4

Record:  Camera 1  Camera 2  Camera 3  Camera 4

Send Video to CenterV2:  Camera 1  Camera 2  Camera 3  Camera 4

PTZ Settings:  Set PTZ camera to preset point

Input on:

Input off:

Duration to set preset after input off:  seconds

Figure 6-10

- **Normal State:** Set up the input state to trigger actions by selecting Open Circuit (N/O) or Grounded Circuit (N/C).
- **Latch Mode:** Enable the mode to have a momentary output alarm.
- **Trigger Digital Output Relay:** Select the output(s) to be triggered once the input is activated.
- **Record:** Select the camera(s) to start recording once the input is activated.
- **Send Video to Center V2:** Select the desired camera(s) to send their images to Center V2 when the input is triggered.

You can direct a PTZ camera to a preset point upon input trigger:

- **Set PTZ camera to preset point:** Enable the preset function and select the camera that maps the PTZ camera.

- **Input on:** Direct the PTZ camera to a preset point when the input is triggered.
- **Input off:** Direct the PTZ camera to another preset point when the triggered input is off.
- **Duration to set preset after input off x seconds:** Specify the amount of time the PTZ camera stays in “Input on” preset point before moving to “Input off” preset point.

**Note:** The functions of triggering the output, the recording and sending video to Center V2 only work after you start **Input** monitoring manually or by schedule. To configure the input monitoring, see [6.4 Monitoring](#) and [6.5.2 I/O Monitoring Settings](#).

For set up a PTZ camera, see [6.2.2 PTZ Settings](#).

### Output Setting

The four-channel GV-Compact DVR V3 can connect up to 4 output devices, such as alarms, while the eight-channel units can connect up to 8 output devices.

Select **Enable** to enable the output device. Choose the output signal that mostly suits the device you are using: N/O (Open Circuit), N/C (Grounded Circuit), N/O Toggle, N/C Toggle, N/O Pulse or N/C Pulse. For **Toggle** output type, the output continues to be triggered until a new input trigger ends the output. For **Pulse** output type, the output is triggered for the amount of time you specify in the Trigger Pulse Mode for x Seconds field.

You can also choose to activate the configured output device automatically under these conditions: video lost, video recording start (Start Record), video recording stop (Stop Record), disk write error (Rec Error) and hard disk full (HD Full).

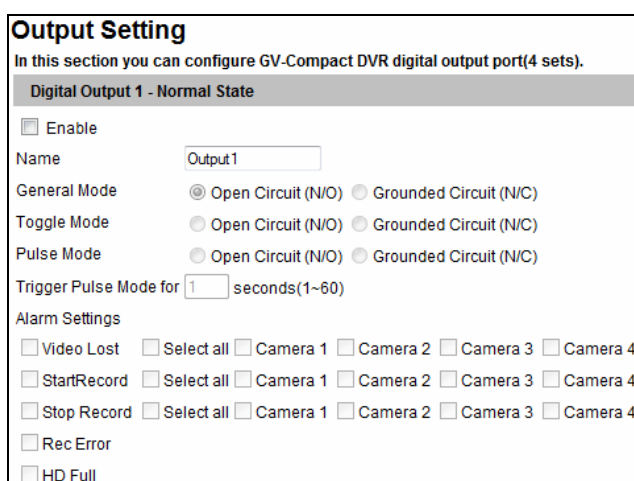
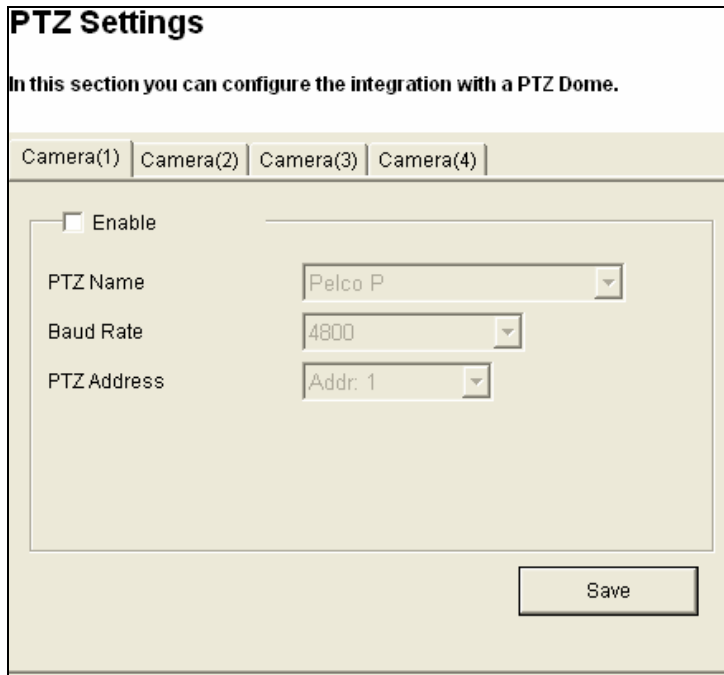

Figure 6-11

**Note:** The **Start Record** and **Stop Record** options are only available for four-channel GV-Compact DVR V3.

## 6.2.2 PTZ Settings

Through the RS-485 interface on the I/O terminal block, the four-channel GV-Compact DVR V3 can connect up to 4 PTZ cameras, while the eight-channel unit can connect up to 8 PTZ cameras. In the setting page, you may need to consult your PTZ camera's documentation to set up its baud rate and address. For supported PTZ device list, see *Appendix F*.



**PTZ Settings**

In this section you can configure the integration with a PTZ Dome.

Camera(1) | Camera(2) | Camera(3) | Camera(4)

Enable

PTZ Name: Pelco P

Baud Rate: 4800

PTZ Address: Addr. 1

Save

Figure 6-12

---

**Note:** Currently the GV-Compact DVR V3 does not support the PTZ camera with RS-232 interface.

---

### 6.2.3 GPS

Note the GPS function is only supported on Anti-Vibration ACC models (GV-LX4C3V / GV-LX8CV1 / GV-LX8CV2).

The Anti-Vibration ACC models support the Global Position System (GPS) for active vehicle tracking and location verification. You can track the vehicle location on Google maps and display the average speed of a vehicle in live view.

**GPS**

In this section you can configure the GPS.

**Device Settings**

Enable GPS

Select GPS Baudrate

Set GPS update frequency  seconds(1~180)

Maximum length of the data to be saved after network connection is broken.  Hours

Figure 6-13

To enable the GPS function:

- **Select GPS Baudrate:** Two baud rate options are available: 4800 and 9600. By default the value is 9600.
- **Set GPS Update Frequency:** Set the update frequency in seconds for GPS data.
- **Maximum length of the data to be saved after network connection is broken:** Specify the duration of GPS data to be saved in the hard disk or storage device of GV-Compact DVR V3 in case that the connection between the GV-Compact DVR V3 and GV-GIS is interrupted. When the connection is resumed, the saved GPS will be automatically sent to the GV-GIS and removed from the storage device.

To display the vehicle speed:

Select Overlaid with the GPS speed on the Video Settings page, and click Apply.

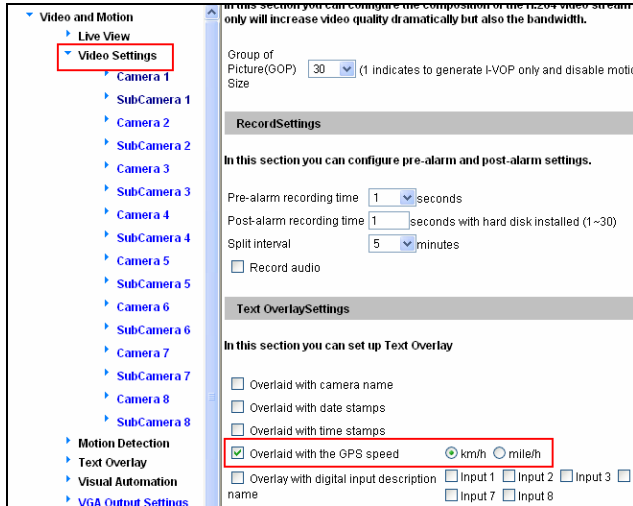

Video Settings page



Vehicle speed in live view

Figure 6-14

To track the vehicle location:

See 8.3 *GPS Tracking*.

**To play back GPS tracks:**

If the monitoring is also activated, the GPS tracks will be recorded along with video. This makes it possible to play back video with GPS tracks on maps using the Remote ViewLog player. See 7.2.5 *Playback of GPS Tracks*.

### 6.2.4 Buzzer

The system buzzer can be activated automatically under these conditions: video lost, input devices triggered, motion detected, disk full and disk write error. The duration of buzzing sounds is definable. When the buzzer starts beeping, pressing any button on the Remote Control can stop it.

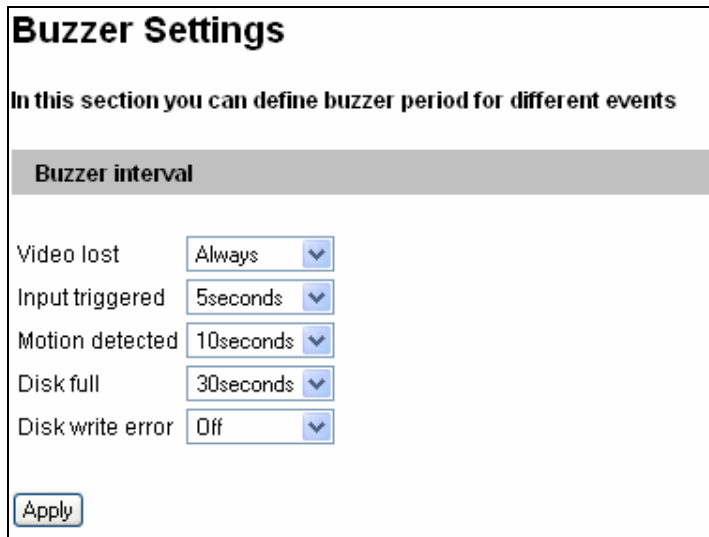

**Buzzer Settings**

In this section you can define buzzer period for different events

**Buzzer interval**

Video lost	Always	▼
Input triggered	5seconds	▼
Motion detected	10seconds	▼
Disk full	30seconds	▼
Disk write error	Off	▼

Apply

Figure 6-15

## 6.2.5 Spot Monitor

If the spot monitor is connected to the GV-Compact DVR V3, configure the settings of the spot monitor.

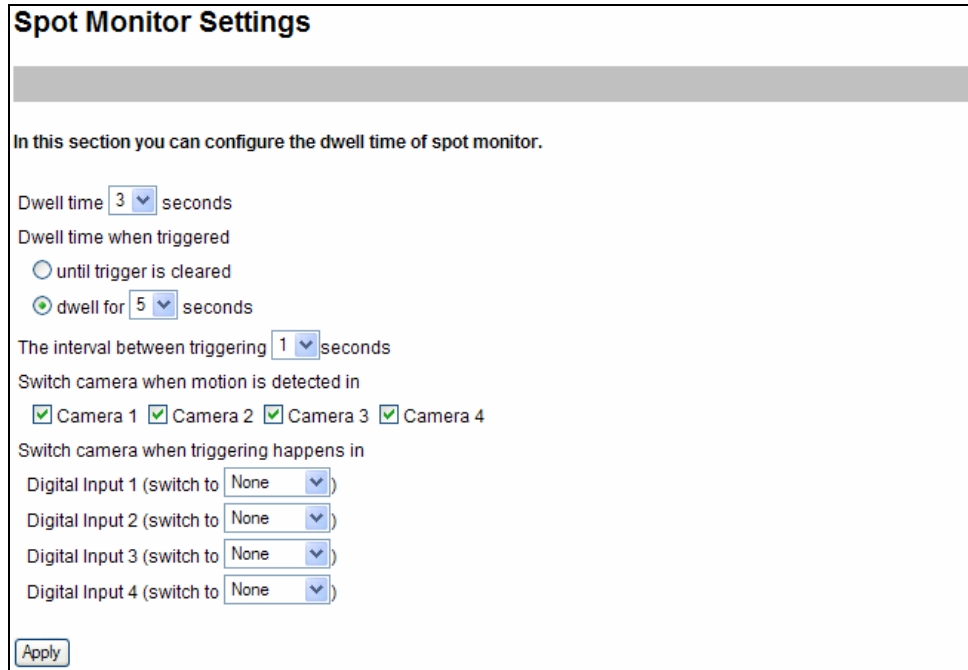

**Spot Monitor Settings**

In this section you can configure the dwell time of spot monitor.

Dwell time  seconds

Dwell time when triggered

until trigger is cleared

dwell for  seconds

The interval between triggering  seconds

Switch camera when motion is detected in

Camera 1  Camera 2  Camera 3  Camera 4

Switch camera when triggering happens in

Digital Input 1 (switch to )

Digital Input 2 (switch to )

Digital Input 3 (switch to )

Digital Input 4 (switch to )

Figure 6-16

- **Dwell time x seconds:** Select the amount of time that each video remains on the spot monitor before the GV-Compact DVR V3 switches to the next video in a rotation. The dwell time can be between 1 and 5 seconds.
- **Dwell time when triggered:** Select the amount of time that the video remains on the spot monitor after the motion or I/O triggered event occurs. The triggered dwell time can be between 1 and 5 seconds. If you select **until trigger is cleared**, the video will remain on the spot monitor until the input trigger stops.
- **The interval between triggering x seconds:** Select the interval between triggered events from 1 to 5 seconds. During the specified length of time, all the triggered events will be ignored. The triggered event after the interval will be displayed on the spot monitor.
- **Switch camera when motion is detected in:** Select the cameras to be displayed upon motion events.
- **Switch camera when triggering happens in:** Select the associated camera to be displayed when an input is triggered.

### 6.3 Events & Alerts

When motion is detected or I/O devices are triggered, the Administrator can set up these alert methods:

1. Send a captured still image by e-mail or FTP.
2. Notify Center Monitoring Station, Center V2, VSM or GV-GIS, by video or text alerts.

To have above alert methods, you must also set the following features:

- Motion Detection (See 6.1.2 *Motion Detection*)---optional
- Input Setting (See 6.2.1 *I/O Control*.)
- For e-mail and FTP alerts, it is required to start monitoring (See 6.4 *Monitoring*).

---

**Note:** The Motion Detection function is an optional setting and it is activated by default.

---



## 6.3.1 E-mail

After a trigger event, the GV-Compact DVR V3 can send the e-mail to a remote user containing a captured still image.

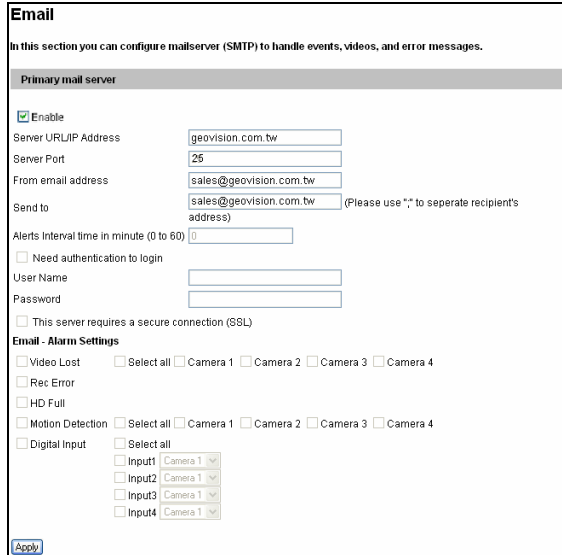

Figure 6-17

**[Enable]** Select to enable the e-mail function.

- **Sever URL/IP Address:** Type the URL or IP address of the SMTP server.
- **Server Port:** Type the SMTP server's port number. Or keep the default value 25.
- **From email address:** Type the sender's e-mail address.
- **Send to:** Type the e-mail address(s) you want to send alerts to.
- **Alerts interval time in minute:** Specify the interval between e-mail alerts. The interval can be between 0 and 60 minutes. The option is useful for the frequent event condition. It will ignore any event triggers during the interval period.

**[Need authentication to login]** If the SMTP server needs authentication, select this option and type the valid username and password.

**[This server requires a secure connection]** If the SMTP Servers needs a secure connection (SSL), select this option.

**[Email-Alarm Settings]** You can choose to automatically send still images via e-mail for alarm notification under these conditions: video lost, disk write error (Rec Error), hard disk full (HD full), motion detection and input triggered.

For the related settings to send e-mail alerts, see *6.1.2 Motion Detection*, *6.2.2 Input/Output Settings* and *6.4 Monitoring*.

### 6.3.2 FTP

You can also send the captured still image to a remote FTP server for alerts.

**FTP Client and Server Setting**

In this section you can configure a ftp server (File Transfer Protocol) to handle events, videos, and error messages.

**Upload to a FTP server**

Enable

Server URL/IP Address:

Server Port:

User Name:

Password:

Remote Directory:

Alerts Interval time in minute (0 to 60):

**FTP - Alarm Settings**

Motion Detection  Select all  Camera 1  Camera 2  Camera 3  Camera 4

Continuously send images upon trigger events(Motion)

Digital Input  Select all

Input1

Input2

Input3

Input4

Continuously send images upon trigger events(Input)

**Act as FTP server**

In this section you can enable/disable GV-Compact DVR internal ftp server for file transfer.

Enable ftp access to GV-Compact DVR

Use alternative Port:

Figure 6-18

#### [Upload to a FTP Server]

- **Enable:** Select to enable the FTP function.
- **Server URL/IP Address:** Type the URL address or IP address of the FTP Server.
- **Port Number:** Type the port number of the FTP Server. Or keep the default value 21.
- **User Name:** Type a valid user name to log into the FTP Server.
- **Password:** Type a valid password to log into the FTP Server.
- **Remote Directory:** Type the name of the storage folder on the FTP Server.
- **Alerts Interval time in minute:** Specify the interval between FTP alerts. The interval can be between 0 and 60 minutes. The option is useful for the frequent event occurrence by which any event triggers during the interval period will be ignored.

### [FTP-Alarm Settings]

- **Motion Detection:** Once the motion is detected on the selected camera, a still image will be sent to the FTP Server.
  - ⊙ **Continuously send images upon trigger events (motion):** A sequence of snapshot images are uploaded to the FTP Server when motion is detected on the selected camera.
- **Digital Input:** Once the selected input is triggered, a still image from the assigned camera will be sent to the FTP Server.
- **Continuously send images upon trigger events (input):** A sequence of snapshot images from the corresponding cameras are uploaded to the FTP Server when the selected input is triggered.

### [Act as FTP Server]

You can enable the GV-Compact DVR V3 to act as a FTP Server, allowing users to download the AVI files. The default download port is 21.

To access the internal FTP server through a Web browser, enter the IP address or the domain name of the GV-Compact DVR V3 in your browser like this:

ftp://192.168.0.10

When you are prompted for Username and Password, enter the default value **ftpuser** in both fields. Then you should find the AVI files recorded after event triggers.

For the related settings to send FTP alerts, see *6.1.2 Motion Detection*, *6.2.1 I/O Control* and *6.4 Monitoring*. To change the login information of the internal FTP Server, see *6.8.4 User Account*.

### 6.3.3 Center V2

After a motion or an I/O triggered event, the central monitoring station Center V2 can get notified by live videos and text alerts. For the live monitoring through Center V2, you must already have a subscriber account on Center V2. The GV-Compact DVR V3 can connect up to two Center V2 servers simultaneously.

The screenshot shows the 'Center V2' configuration page with two tabs: 'Connection 1' and 'Connection 2'. The page is titled 'Center V2' and contains the following sections:

- Center V2 server**:
  - Activate Link:
  - Host name or IP Address:
  - Port number:
  - User Name:
  - Password:
  - Cease motion detection messages from:  Select all  Camera 1  Camera 2  Camera 3  Camera 4
  - Cease input trigger message from:  Select all  Input 1  Input 2  Input 3  Input 4
  - Cease video lost messages from:  Select all  Camera 1  Camera 2  Camera 3  Camera 4
  - Enable schedule mode:
- Apply** button
- Select schedule time**:
  - Span 1:  00 : 00 ~ 00 : 00 Next Day
  - Span 2:  00 : 00 ~ 00 : 00 Next Day
  - Span 3:  00 : 00 ~ 00 : 00 Next Day
  - Weekend:  Saturday and Sunday  Only Sunday
- Apply** button
- Connection Status**:
  - Status: Disconnected

Figure 6-19

To enable the Center V2 connection:

1. **Activate Link:** Enable the monitoring through Center V2.
2. **Host Name or IP Address:** Type the host name or IP address of Center V2.
3. **Port Number:** Type the port matching the **Port 2** on Center V2. Or keep the default value 5551. Refer to *11.1 Center V2*.
4. **User Name:** Type a valid user name to log into Center V2.
5. **Password:** Type a valid password to log into Center V2.
6. Click **Apply**. The Connection Status should display “Connected” and connected time.
7. To establish connection to the second Center V2 server, click the **Connection 2** tab and repeat the steps 1 to 6 settings.

These options you can also find on this Center V2 setting page:

- **Cease motion detection messages from:** Stops notifying Center V2 of motion detection from selected camera.
- **Cease input trigger messages from:** Stops notifying Center V2 of input trigger from selected input.
- **Cease video lost messages from:** Stops notifying Center V2 of video lost from selected camera
- **Enable schedule mode:** Starts the monitoring through Center V2 based on the schedule you set in the **Select Schedule Time** section. Refer to *6.5 Recording Schedule* for the same settings.

For related settings to activate the monitoring through Center V2, see *6.1.2 Motion Detection*, *6.2.1 I/O Control*, and *11.1 Center V2*.

### 6.3.4 VSM

After a motion or an I/O triggered event, the central monitoring station VSM can get notified by text alerts. For the live monitoring through VSM, you must already have a subscriber account on VSM. The GV-Compact DVR V3 can connect up to two VSM simultaneously.

**Connection 1** | **Connection 2**

#### Vital Sign Monitor Server Setting

In this section you can configure the connection to VSM Server and tasks to perform.

##### Vital Sign Monitor Server

Activate Link

Host name or IP Address:

Port number:

User Name:

Password:

Cease motion detection messages from  Select all  Camera 1  Camera 2  Camera 3  Camera 4

Cease input trigger message from  Select all  Input 1  Input 2  Input 3  Input 4

Cease video lost messages from  Select all  Camera 1  Camera 2  Camera 3  Camera 4

Enable schedule mode

**Apply**

##### Select schedule time

Span 1  :  :  :  **Next Day**

Span 2  :  :  :  **Next Day**

Span 3  :  :  :  **Next Day**

Weekend  Saturday and Sunday  Only Sunday

**Apply**

##### Connection Status

Status: Disconnected

Figure 6-20

To enable the VSM connection:

1. **Activate Link:** Enable the monitoring through VSM.
2. **Host Name or IP Address:** Type the host name or IP address of VSM.
3. **Port Number:** Type the port matching the **Port 2** on VSM. Or keep the default value 5609. Refer to 11.2 VSM.
4. **User Name:** Type a valid user name to log into VSM.
5. **Password:** Type a valid password to log into VSM.
6. Click **Apply**. The Connection Status should display “Connected” and connected time.
7. To establish connection to a second VSM, click the **Connection 2** tab and repeat steps 1 to 6 for settings.

These options you can also find on this VSM setting page:

- **Cease motion detection messages from:** Stops notifying VSM of motion detection from selected camera.
- **Cease input trigger messages from:** Stops notifying VSM of input trigger from selected input.
- **Cease video lost messages from:** Stops notifying VSM of video lost from selected camera
- **Enable schedule mode:** Starts the monitoring through VSM based on the schedule you set in the **Select Schedule Time** section. Refer to *6.5 Recording Schedule* for the same settings.

For related settings to activate the monitoring through VSM, see *6.1.2 Motion Detection*, *6.2.1 I/O Control*, and *11.2 VSM*.

### 6.3.5 GV-GIS

Note the GV-GIS function is only supported on **Anti-Vibration ACC models** (GV-LX4C3V, GV-LX8CV1 and GV-LX8CV2).

Through the network connection, the Anti-Vibration ACC models equipped with GPS devices can send GPS data and live video to the GV-GIS (Geographic Information System) for the services of vehicle tracking, location verification and live monitoring. The GV-Compact DVR V3 can connect up to two GV-GIS simultaneously.

Before you configure the GV-GIS connection on this setting page, the following conditions must be met:

- A subscriber account created on the GV-GIS
- UMTS connection activated on the GV-Compact DVR V3 (See 6.7.4 UMTS/ZigBee)
- GPS function activated on the GV-Compact DVR V3 (See 6.2.3 GPS)

For details on the GV-GIS, see *GV-CMS Series User's Manual*.



Connection 1
Connection 2

### GV-GIS

In this section you can configure the connection to GV-GIS and tasks to perform.

**GV-GIS Server**

Activate Link

Host name or IP Address:

Port number:

User Name:

Password:

Enable schedule mode

**Select schedule time**

Span 1  :  ~  :  Next Day

Span 2  :  ~  :  Next Day

Span 3  :  ~  :  Next Day

Weekend  Saturday and Sunday  Only Sunday

**Connection Status**

Status: Disconnected

Figure 6-21

To enable the GV-GIS connection:

1. **Activate Link:** Enable the monitoring through GV-GIS.
2. **Host Name or IP Address:** Type the host name or IP address of GV-GIS.
3. **Port Number:** Match the communication port on GV-GIS. Or keep the default value 3356.
4. **User Name:** Type a valid user name to log into GV-GIS.
5. **Password:** Type a valid password to log into GV-GIS.
6. Click **Apply**. The Connection Status should display “Connected” and connected time.
7. To establish the connection to the second GV-GIS, click the **Connection 2** tab and repeat the steps above for settings.

For related settings to activate the monitoring through GV-GIS, see *6.1.2 Motion Detection*, and *6.2.1 I/O Control*.

### 6.3.6 Backup Center

The GV-Backup Center provides a PC-based storage and backup solution. The connection to the GV-Backup Center allows you to back up another copy of recordings and system log to a pc-based GV-Backup Center while the GV-Compact DVR V3 is saving these data to the attached hard disk.

For details on GV-Backup Center, see *GV-Backup Center User's Manual*.

#### Backup Center

In this section you can configure the connection to Backup Center and tasks to perform

Backup Center

Activate Link

Host name or IP Address:

Port number:

User Name:

Password:

Backup Video  Select all  Camera 1  Camera 2  
 Camera 3  Camera 4

Compact Video  Select all  Camera 1  Camera 2  
 Camera 3  Camera 4

Resend all files

Automatic Failover Support

Host name or IP Address:

Port number:

User Name:

Password:

Enable schedule mode

Select schedule time

Span 1  :  :  :  Next Day

Span 2  :  :  :  Next Day

Span 3  :  :  :  Next Day

Weekend  Saturday and Sunday  Only Sunday

Special Day (MM/DD)

Figure 6-22

To enable the Backup Center connection:

1. **Activate Link:** Enable the connection to the Backup Center.
2. **Host Name or IP Address:** Type the host name or IP address of the Backup Center.
3. **Port Number:** Match the communication port on the Backup Center. Or keep the default value 30000.
4. **User Name:** Type a valid user name to log into the Backup Center.
5. **Backup Video:** Select the cameras that you want to back up their recordings to the Backup Center..
6. **Compact Video:** Select the cameras that you only want to back up their Key Frames to the Backup Center, instead of full recordings. This option is useful to save the backup time.
7. **Resend all files:** Select this option to send all the recorded files that have received by the Backup Center again.
8. **Password:** Type a valid password to log into the Backup Center.
9. **Enable Schedule Mode:** Enable the Backup Center connection on the schedule you set in the **Select Schedule Time** section. Refer to *6.5 Recording Schedule* for the same settings.
10. Click **Apply**. The Connection Status should display “Connected” and connected time.

If the Backup Center has a failover server providing the uninterrupted backup services in case of the Backup Center failure, you can configure the connection to the failover server.

1. **Set Update Frequency:** Once the GV-Compact DVR V3 is disconnected from the Backup Center for the specified time, the GV-Compact DVR V3 will be directed to the failover server.
2. **Automatic Failover Support:** Enable the automatic connection to the failover server once the connection between GV-Compact DVR V3 and Backup Center is interrupted for the specified time.
3. **Host Name or IP Address:** Type the host name or IP address of the failover center.
4. **Port Number:** Match the communication port on the failover server. Or keep the default value 30000.
5. **User Name:** Type a valid user name to log into the failover server.
6. **Password:** Type a valid password to log into the failover server.
7. Click **Apply**.

### 6.3.7 Video Gateway / Recording Server

The GV-Recording Server and GV-Video Gateway are a video streaming server designed for large-scale video surveillance deployments. The servers can receive up to 128 channels from various IP video devices, and distribute up to 300 channels to its clients. With the GV-Recording Server and GV-Video Gateway, the desired frame rate can be ensured while the CPU loading and bandwidth usage of the IP video devices are significantly reduced.

The screenshot shows a web-based configuration page for a Video Gateway / Recording Server. At the top, there are tabs for 'Connection 1' and 'Connection 2'. The main title is 'Video Gateway / Recording Server'. Below the title, there is a sub-header 'Video Gateway server / Recording Server'. The configuration area includes several fields: 'Activate Link' (checkbox), 'Host name or IP Address' (text input), 'Port number' (text input with '50000' entered), 'User Name' (text input), 'Password' (text input), and 'Enable schedule mode' (checkbox). An 'Apply' button is located below these fields. The next section is 'Select schedule time', which includes three 'Span' options (Span 1, Span 2, Span 3) each with time selection dropdowns and 'Next Day' links, and a 'Weekend' option with radio buttons for 'Saturday and Sunday' (selected) and 'Only Sunday'. Another 'Apply' button is located below this section. The final section is 'Connection Status', which shows 'Status: Disconnected'.

Figure 6-23

To enable the GV-Video Gateway and GV-Recording Server connection:

1. **Activate Link:** Enable the connection to GV-Video Gateway / GV-Video Server.
2. **Host Name or IP Address:** Type the host name or IP address of GV-Video Gateway / GV-Recording Server.
3. **Port Number:** Match the communication port on GV-Video Gateway / GV-Recording Server. Or keep the default value 50000.
4. **User Name:** Type a valid user name to log into GV-Video Gateway / GV-Recording Server.

5. **Password:** Type a valid password to log into GV-Video Gateway / GV-Recording Server.
6. **Enable schedule mode:** Enable the GV-Video Gateway / GV-Recording Server connection on the schedule you set in the **Select Schedule Time** section. Refer to *6.5 Recording Schedule* for the same settings.
7. Click **Apply**. The Connection Status should display “Connected” and connected time.
8. To establish the connection to the second GV-Video Gateway / GV-Recording Server, click the **Connection 2** tab and repeat above steps for setup.

### 6.3.8 ViewLog Server

The ViewLog Server is designed for remote playback. This server allows you to remotely access the recorded files saved on the GV-Compact DVR V3 and play back video with the ViewLog player.

Select **Enable** to activate the server built in the unit and to allow the playback access. Keep the default port **5552** or modify it if necessary. For details on the remote playback, see 7.2.2 *Playback over Network*.

**Viewlog Server Settings**

In this section you can configure the connection to Viewlog Server and tasks to perform.

**Viewlog Server**

Enable

Port number:

Figure 6-24

### 6.3.9 RTSP / 3GPP

The RTSP / 3GPP Server allows you to enable the Real Time Stream Protocol (RTSP) and watch live streaming by using VLC or QuickTime player. For the RTSP command, see *RTSP Protocol Support* in Appendix E.

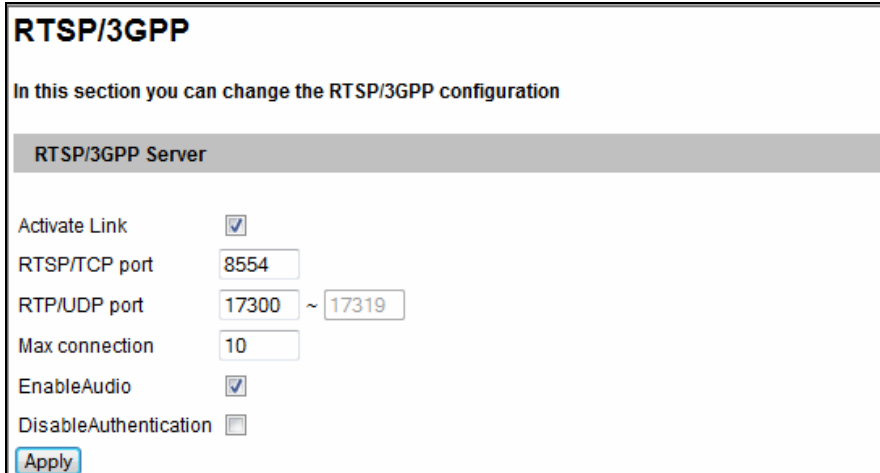

Figure 6-25

- **Activate Link:** Enable the RTSP protocol.
- **RTSP/TCP Port:** Keep the default value 8554, or modify it if necessary.
- **RTP/UDP Port:** Keep the default range from 17300 to 17319, or modify it if necessary. The number of ports for use is limited to 20.
- **Max Connection:** Set the maximum number of RTSP connections to the GV-Compact DVR V3. The maximum value is 20.
- **Enable Audio:** Enable audio streaming.
- **Disable Authentication:** By default, when accessing live view through RTSP command, the ID and password of the GV-Compact DVR V3 are required. Select this option to disable the authentication prompt. For details on the RTSP command, see *Appendix E*.

---

**Note:**

1. In four-channel models, you can only enable either RTSP or Multicast; the two protocols cannot function at the same time.
  2. In eight-channel modes, when 3GPP server (RTSP) is enabled, you cannot access live view through the Web interface at the same time.
-

## 6.4 Monitoring

You can start recording manually, by schedule or by input trigger.

**Monitoring Settings**

In this section you can set up, and start/stop monitoring in manual or scheduled mode.

**Monitoring Settings**

Manual

Select all

Camera 1 Round the clock ▼

Camera 2 Round the clock ▼

Camera 3 Round the clock ▼

Camera 4 Round the clock ▼

Input

Schedule

Start monitoring by Input1 ▼

Stop monitoring by Input1 ▼  Remove HDD

Figure 6-26

**[Manual]** Manually activates recording and I/O monitoring. Select one of the following options and then click the **Start** button.

- **Select all:** Manually starts recording and I/O monitoring as well.
- **Camera x:** Manually starts recording. Select the desired camera(s) and the recording mode for recording.
- **Input:** Manually starts I/O monitoring. When the input is triggered, its associated camera and output will also be activated for recording and alerting. For input settings, see 6.2.1 *I/O Control*.

**[Schedule]** The system starts recording and I/O monitoring based on the schedule you set. For schedule settings, see 6.5 *Recording Schedule*.

**[Start monitoring by Input X]** Starts monitoring by the assigned input. When the assigned input is triggered, the system will respond based on your recording or I/O monitoring settings in above **Manual** or **Schedule** options.

**[Stop monitoring by Input X]** Stops monitoring by the assigned input. When the assigned input is triggered, the system will stop monitoring.

- **Remove HDD:** Detaches the hard disk from the system when the unit stops monitoring.



**[Camera Status Icon]**

 : Manual recording

 : Schedule recording

 : On standby

 : Enabled for motion detection and input trigger

## 6.5 Recording Schedule

The schedule is provided to activate recording and I/O monitoring on a specific time each day.

### 6.5.1 Recording Schedule Settings

You can set up different monitoring schedules for each camera.

Figure 6-27

- **Span 1- Span 3:** Set a different recording mode for each time frame during the day. Each day can be divided into 3 time frames, represented by Span 1 to Span 3.
- **Weekend:** If you want to have the camera monitoring all day during the weekend, enable this option and select the recording mode to be used on the weekend. Define whether your weekend includes **Saturday and Sunday** or **Only Sunday**.
- **Special Day:** Set the recording mode on a specified day.

---

**Note:** In Recording Schedule and I/O Monitoring Schedule, if the settings for Special Day conflict with those for Span 1-3 or Weekend, the Special Day settings will get priority.

---

To start the scheduled recording, you must select **Schedule** to be the monitoring mode. See *6.4 Monitoring*.

## 6.5.2 I/O Monitoring Settings

You can set up the schedule for I/O monitoring to start.

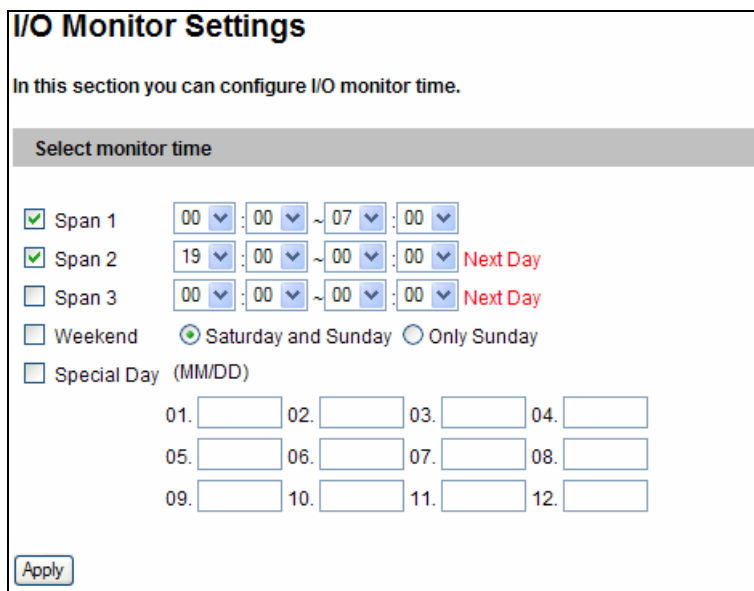

Figure 6-28

- **Span 1 to Span 3:** Set different time frames during the day to enable I/O monitoring. Each day can be divided into 3 time frames, represented by Span 1 to Span 3.
- **Weekend:** If you want to have the I/O monitoring all day during the weekend, enable this option and define whether your weekend includes **Saturday and Sunday** or **Only Sunday**.
- **Special Day:** Enable I/O monitoring on a specified day.

To start the scheduled recording, you must select **Schedule** to be the monitoring mode. See *6.4 Monitoring*.

## 6.6 Remote ViewLog

With the Remote ViewLog player, you can remotely play back the files recorded at the GV-Compact DVR V3 over TCP/IP network.

For the first-time user, you need to install the Remote ViewLog program from the Software CD to initiate the function. And to allow the playback access, the **ViewLog Server** built in the unit must be enabled. See *6.3.8 ViewLog Server*.

For details on connecting to the GV-Compact DVR V3 for playback, see *7.2.2 Playback over Network*.

## 6.7 Network

The Network section includes some basic but important network configurations that enable the GV-Compact DVR V3 to be connected to a TCP/IP network.

### 6.7.1 LAN

According to your network environment, select among Static IP, DHCP and PPPoE to configure an IP address to the GV-Compact DVR V3.

#### LAN Configuration

In this section you can configure GV-Compact DVR to work inside of LAN.

**Optional Network type**

Wired Ethernet Select this option to use wired 10/100Mbps ethernet  
 Wireless Select this option to use Wireless

**LAN Configuration**

Dynamic IP address Select this option to obtain IP address from a DHCP server Test DHCP  
 Static IP address Select this option to enter a Static IP address manually

IP Address:   
 Subnet Mask:   
 Router/Gateway:   
 Primary DNS:   
 Secondary DNS:  (Optional)

PPPoE Select this option to establish a DSL connection

Username:   
 Password:

**Wireless Settings**

Dynamic IP address Select this option to obtain IP address from a DHCP server Test DHCP  
 Static IP address Select this option to enter a Static IP address manually

IP Address:   
 Subnet Mask:   
 Router/Gateway:   
 Primary DNS:   
 Secondary DNS:  (Optional)

Apply

Figure 6-29

**[LAN Configuration]**

According to the network environment, select **Wired** or **Wireless**.

Before enabling **Wireless**, set up a wireless module first. For details, see 6.7.2 *Wireless-Client Mode*.

**[LAN Configuration]**

- **Dynamic IP address:** Assign a dynamic IP by the DHCP server. By default the GV-Compact DVR V3 will be automatically assigned a dynamic IP address by the DHCP server. To check the current IP address, click the **Test DHCP** button.
- **Static IP address:** Assign a static IP or fixed IP to the GV-Compact DVR V3. Type the GV-Compact DVR V3's IP address, Subnet Mask, Gateway and DNS Server parameters.

If no DHCP server exists in your network environment, the following default IP address will be assigned to the GV-Compact DVR V3.

Parameters	Default
IP address	192.168.0.10
Subnet Mask	255.255.255.0
Router/Gateway	192.168.0.1
Primary DNS server	192.168.0.1
Secondary DNS server	192.168.0.2

- **PPPoE:** Establish the connection to your ISP. Type the username and password provided by the ISP to establish the connection. However, if the IP address provided by your ISP is dynamic, use the DDNS function to obtain a domain name linking to the unit's changing IP address before enabling the PPPoE function. For details on Dynamic DNS Server Settings, see 6.7.3 *Advanced TCP/IP*.

---

**Note:** To establish connection through a broadband modem, you may refer to this article: [ftp://geo-demo-japan.dipmap.com/Technotice/GV\\_IP\\_Devices/How to access GV-IP Camera through broadband modem.pdf](ftp://geo-demo-japan.dipmap.com/Technotice/GV_IP_Devices/How_to_access_GV-IP_Camera_through_broadband_modem.pdf)

---

## [Wireless Settings]

Before enabling **Wireless**, set up a wireless module first. For details, see 6.7.2

*Wireless-Client Mode*. Then you can select the **Dynamic IP Address** or **Static IP Address** in this section for the wireless LAN. By default, the following static IP address will be applied for wireless connection.

Parameters	Default
IP address	192.168.100.10
Subnet Mask	255.255.255.0
Router/Gateway	192.168.0.1
Primary DNS server	192.168.0.1
Secondary DNS server	192.168.0.2

## 6.7.2 Wireless-Client Mode

To use the wireless function, a wireless LAN USB Adaptor is required. For supported wireless LAN adaptors, see *Appendix A*.

Figure 6-30

- **Network type:** Select the network mode **Ad Hoc** or **Infrastructure**.
  - ⊙ **Infrastructure:** Via the Access Point to connect to the Internet. This mode further gives wireless access to the Internet or data sharing under a previously wired environment.
  - ⊙ **Ad-Hoc:** A Peer-to-Peer mode. This mode connects to other computer with the WLAN card, and does not need the Access Point to connect to each other.
- **Network name (SSID):** The SSID (Service Set Identify) is a unique name that identifies a particular wireless network. Type SSID of the Wireless LAN group or Access Point you are going to connect to.
  - ⊙ **Access Point Survey:** Click this button to search all the available Access Points (Infrastructure mode) and wireless stations (AD-Hoc mode) within the range of your WLAN card.
- **Authentication Type:** Select one of these network authentication and data encryption: **Disable**, **WEP**, **WPAPSK-TKIP**, **WPAPSK-AES**, **WPA2PSK-TKIP** or **WPA2PSK-AES**.
  - ⊙ **Disabled:** No authentication is needed within the wireless network.



- ⊙ **WEP (Wired Equivalent Privacy):** A type of data encryption. Type up to four WEP Keys in HEX or ASCII format. Note that if you use HEX format, only digits 0-9 and letters A-F, a-f are valid.
- ⊙ **WPAPSK-TKIP** and **WPA2PSK-TKIP:** Type WPA-PSK (Pre-Shared Key) for data encryption.
- ⊙ **WPAPSK-AES** and **WPA2PSK-AES:** Type WPA-PSK (Pre-Shared Key) for data encryption.

---

**Note:**

1. Your encryption settings must match those used by the Access Points or wireless stations with which you want to associate.
  2. When you lose the wireless access, you can still access the unit by connecting it to a LAN and using the default IP address 192.168.0.10.
-

### 6.7.3 Advanced TCP/IP

This section introduces the advanced TCP/IP settings, including DDNS server, HTTP port, HTTPS port, streaming port and UPnP.

#### Advanced TCP/IP

In this section you can set the advanced TCP/IP configuration

---

##### Dynamic DNS Server Settings

In this section you can configure your GV-Compact DVR to obtain a domain name by using a dynamic IP.

Enable

Service Provider: Geovision DDNS Server ex: Register Geovision DDNS Server

Host Name:

User Name:

Password:

Update Time: Refresh

---

##### HTTP Port Settings

In this section you can change the default HTTP port number (80) to any port within the range 1024-65535. It is a simple method to increase system security using port mapping. You can configure HTTP connection to an alternative port.

HTTP Port:

---

##### HTTPS Settings

In this section you can change the default HTTPS port number (443) to any port within the range 1024-65535. It is a simple method to increase system security using port mapping. You can configure HTTPS connection to an alternative port.

External storage is not available. Cannot upload customized certification and private key.

Enable

HTTP Port:

Use customized certification and private key. External storage is necessary.

Certification:

Private Key:

Password:

---

##### GV-Compact DVR Streaming Port Settings

In this section you can configure Streaming connection from a determine port. The default setting is 10000.

VSS Port:

---

##### UPnP Settings

In this section you can enable or disable UPnP function.

UPnP:  Enable  Disable

UPnP/DLNA:  Enable  Disable

Figure 6-31

### [Dynamic DNS Server Settings]

DDNS (Dynamic Domain Name System) provides a convenient way of accessing the GV-Compact DVR V3 when using a dynamic IP. DDNS assigns a domain name to the unit, so that the Administrator does not need to go through the trouble of checking if the IP address assigned by DHCP server or ISP (in xDSL connection) has changed.

Before enabling the DDNS function, the Administrator should apply for a Host Name from the DDNS service provider's website. There are 2 providers listed on the GV-Compact DVR V3: GeoVision DDNS Server and DynDNS.org.

#### To enable the DDNS function:

1. **Enable:** Enable the DDNS function.
2. **Service Provider:** Select the DDNS service provider you have registered with.
3. **Host Name:** Type the host name used to link to the GV-Compact DVR V3. For the users of GeoVision DDNS Server, it is unnecessary to fill the field because the system will detect the host name automatically.
4. **User Name:** Type the user name used to enable the service from the DDNS.
5. **Password:** Type the password used to enable the service from the DDNS.
6. Click **Apply**.

### [HTTP Port Settings]

The HTTP port enables connecting the GV-Compact DVR V3 to the Web. For security integration, the Administrator can hide the server from the general HTTP port by changing the default HTTP port of 80 to a different port number within the range of 1024 thru 65535.

### [HTTPS Settings]

By enabling the Hypertext Transfer Protocol Secure (HTTPS) settings, you can access the camera through a secure protocol. You can use self-generated Certificate and Private Key or the ones verified by the SSL authority. Click **Browse** to locate the Certificate and Private Key files and type the password if the .pem files are protected by password. Click **Apply**. The Web interface will be restarted and you will need to log in again.

---

**Note:** The .pem file format is supported by Certificate and Private Key.

---

**[GV-Compact DVR Streaming Port Settings]**

The VSS port enables connecting the GV-Compact DVR V3 to the GV-System. The default setting is 10000.

**[UPnP Settings]**

- **UPNP:** UPnP (Universal Plug & Play) is a networking architecture that provides compatibility among networking equipment, software and peripherals of the 400+ vendors that are part of the Universal Plug and Play Forum. It means that they are listed in the network devices table for the operating system (such as Windows XP) supported by this function. Enabling this function, you can connect to the GV-Compact DVR V3 directly by clicking on the GV-Compact DVR V3 listed in the network devices table.
- **DLNA:** allows the DLNA certified devices to automatically communicate with each other once connected to the same network. The function is currently supported with Windows Media Player for recording playback.

---

**Note:**

1. The DLNA function is only supported with Windows Media Player version 1.1 or later. You must have installed GeoVision codec from the Software CD/DVD or have accessed the GV-Compact DVR V3 Web interface on the computer with Windows Media Player.
  2. The DLNA function does not support the connection to TV.
-

## 6.7.4 UMTS / ZigBee

UMTS stands for Universal Mobile Telephone System. UMTS is a third-generation (3G) broadband, packet-based transmission of text, digitized voice, video, and multimedia at data rates up to 2 megabits per second. UMTS offers a consistent set of services to mobile computer and phone users, no matter where they are located in the world.

After a mobile broadband device (supporting UMTS, HSDPA, etc.) is attached to the USB port on the front panel and the UMTS function is enabled, the GV-Compact DVR V3 can have wireless Internet connectivity. For supported mobile broadband devices, see *Appendix B*.

The Virtual Private Network (VPN) over a UMTS connection is also configurable in the setting page.

### UMTS Settings

In this section you can configure the UMTS settings

---

#### UMTS Settings

**Set Up UMTS Device**

Enable

PIN Number

Access Point Name (APN)

Username

Password

Maximum Transmission Unit

Retain UMTS connection

Check Interval

Enable VPN Connection

Check Target IP Address

UMTS Authentication Protocol

Enable schedule mode

Enable DNS

Primary DNS:

Secondary DNS:  (Optional)

---

#### ZigBee Settings

Enable ZigBee

Maximum length of the data to be saved after network connection is broken.  Hours

Delete the saved data in HD

---

#### Select schedule time

Span 1  :  ~  :  Next Day

Span 2  :  ~  :  Next Day

Span 3  :  ~  :  Next Day

Weekend  Saturday and Sunday  Only Sunday

---

#### 3GConnection Status

Disconnection

Figure 6-32

**[UMTS Settings]**

- **PIN number:** Type the PIN number that is provided by your network operator.
- **Access Point Name (APN):** Type Access Point Name that is provided by your network operator.
- **Username:** Type a valid username to enable the UMTS service from your network operator.
- **Password:** Type a valid password to enable the UMTS service from your network operator.
- **Maximum Transmission Unit:** Type the Maximum Transfer Unit (MTU). The default value is 1500.
- **Retain UMTS Connection:** Select this option to check the UMTS connection status and use the drop-down list to specify the time length for check frequency. The GV-Compact DVR V3 will attempt connection if disconnection is detected.
- **Enable VPN Connection:** Select this option to enable the Virtual Private Network (VPN) connection. Enter the IP address of a VPN client in the **Check Target IP Address** field.
- **Enable DNS:** Optionally type up to two DNS servers of your network operator.

**[ZigBee Settings]** Enable the ZigBee application.

**[3G Connection Status]** Indicate the connection status of UMTS or VPN.

## 6.7.5 Multicast

Note the Multicast function is only available for the **four-channel GV-Compact DVR V3**.

The multicast provides a mechanism for sending a single video and audio stream to a group of hosts. Only the hosts that have joined a multicast group can send and receive the multicast streams. The multicast streams are only sent to the groups of hosts on a local network.

This configuration page provides two settings. One is to allow the GV-Compact DVR V3 to join a multicast group. The other is to allow the GV-Compact DVR V3 to receive audio broadcasting from other hosts in a multicast group.

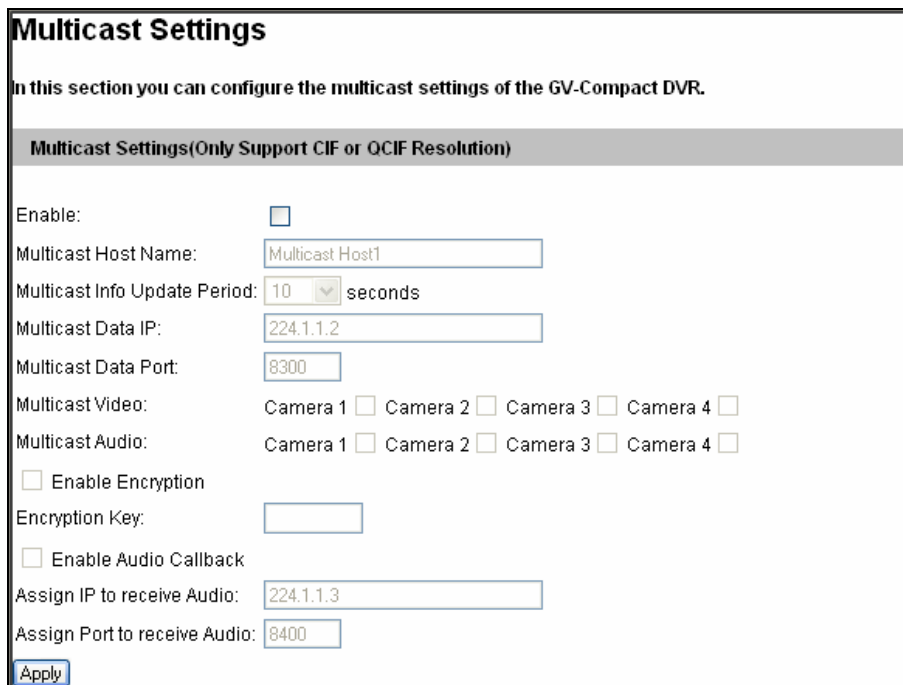

**Multicast Settings**

In this section you can configure the multicast settings of the GV-Compact DVR.

**Multicast Settings(Only Support CIF or QCIF Resolution)**

Enable:

Multicast Host Name:

Multicast Info Update Period:  seconds

Multicast Data IP:

Multicast Data Port:

Multicast Video: Camera 1  Camera 2  Camera 3  Camera 4

Multicast Audio: Camera 1  Camera 2  Camera 3  Camera 4

Enable Encryption

Encryption Key:

Enable Audio Callback

Assign IP to receive Audio:

Assign Port to receive Audio:

Figure 6-33

- **Multicast Host Name:** Name the GV-Compact DVR V3 in a multicast group.
- **Multicast Info Update Period:** Set the time length between each update of multicast streams.
- **Multicast Data IP:** Type the IP address used for multicasting. The default IP address is 224.1.1.2.
- **Multicast Data Port:** Type the port used for multicasting. The default value is 8300.
- **Multicast Video:** Select the camera to send its video through multicasting.
- **Multicast Audio:** Select the audio to send its audio through multicasting.

- **Enable Encryption:** Enable this option and type the Encryption Key to secure multicast streams. The hosts in the multicast group will need to enter the Key to access the video and audio streams.
- **Enable Audio callback:** Enable this option to receive audio broadcasting from the hosts in the multicast group. Specify the IP address and port number to receive the audio broadcast. The default IP address is 224.1.1.3 and port number is 8400.

To receive the multicast stream, see *5.3.15 Multicast*.

---

**Note:** You can only enable either RTSP or Multicast; the two protocols cannot function at the same time.

---



## 6.7.6 IP Filtering

The Administrator can set IP filtering to restrict access to the GV-Compact DVR V3.

### IP Filter Setting

IP Filtering

In this section you can allow or deny network connection listed in the table.

Enable IP Filtering

No.	IP Address Range in CIDR format	Action	Customize
The IP Filter has not been configured yet			

Filtered IP:  (ex: 192.168.0.0/24)

Action to take:

*Figure 6-34*

To enable the IP Filter function:

1. **Enable IP Filtering:** Enable the IP Filtering function.
2. **Filtered IP:** Type the IP address you want to restrict the access.
3. **Action to take:** Select the action of **Allow** or **Deny** to be taken for the IP address(es) you have specified.
4. Click **Apply**.

### 6.7.7 SNMP Setting

The Simple Network Management Protocol (SNMP) allows you to monitor the status of the camera through SNMP network management software.

**SNMP Setting**

In this section you can configure the SNMP settings.

**SNMP Configuration**

Enable SNMPv1, SNMPv2c

Read/Write community

Read only community

Enable SNMPv3

Read/Write Security name

Authentication Type

Authentication Password

Encryption Password

Read only Security name

Authentication Type

Authentication Password

Encryption Password

Figure 6-35

1. Select **Enable SNMPv1 SNMPv2c** to enable the function.
2. To enable access to **Read/Write community**, type a community string. This will serve as a password to allow read and write access to the camera from the SNMP software.
3. To enable **Read only community**, type a community string to allow read-only access to the camera from the SNMP software.
4. For a more secured connection, select **Enable SNMPv3** to enable SNMP version 3.
5. To enable access to SNMPv3 **Read/Write community**, type a community string.
6. Select an **Authentication Type** to use for SNMP requests.
7. Type the **Authentication Password** and **Encryption Password**. You will need to type these passwords in the SNMP software to be able to access the camera.
8. To enable access to SNMPv3 Read only community, follow steps 5 to 7.
9. Click **Apply** to save the settings.

## 6.8 Management

The Management section includes the settings of data and time, storage device and user account. In addition, you can view the firmware version and execute certain system operations.

### 6.8.1 Date & Time Setting

The date and time settings are used for date and time stamps on the image.

#### Date and Time Settings

In this section you can configure time and date or just synchronize with a NTP server.

**Date and Time on GV-Compact DVR**

Wed Jul 21 15:19:55 2010

**Time Zone**

(GMT+08:00) China, Hong Kong, Australia Western, Singapore, Taiwan, Russia ▼

Enable Daylight Saving Time

Start  (MM/dd/hh/mm)

End  (MM/dd/hh/mm)

**Synchronized with a Network Time Server**

Synchronized with Network Time Server (NTP)

Host name or IP Address:

Update period: 24 hours; Update Time:  :

**Synchronized with your computer or modify manually**

Modify manually

Date  (yyyy/mm/dd)

Time  (hh:mm:ss)

Synchronized with your computer

**Date and time overlay setting**

Show date as  ▼

(This is a format of date where yyyy stands for year in 4 digits or yy in 2 digits, mm stands for month, and dd stands for day)

Display order  Date prior to time (Ex.2007/05/21 17:00:00)

Figure 6-36

**[Date & Time on Device]** Displays the current date and time on the GV-Compact DVR V3.

**[Time Zone]** Sets the time zone for local settings. Select **Enable Daylight Saving Time** to automatically adjust the GV-Compact DVR V3 for daylight saving time. Type the Start Time and End Time to enable the function. To play back, see *7.2.4 Playback of Backup Files*. To automatically synchronize the Day Light Saving Time with the GV-System, see *Configuring the Compact DVR Settings, 10.1 Setting Up GV-Compact DVR V3*.

**[Synchronized with a Network Time Server]** By default, the GV-Compact DVR V3 uses the timeserver of time.windows.com to automatically update its internal clock every 24 hours. You can define the update time. The host name or IP setting can also be changed to the timeserver of interest.

---

**Note:** The default setting with the time server can avoid the system time delay. If your GV-Compact DVR is not networked or the time server is not enabled, the system time may delay about 1.5 second every 24 hours. In such case, you could update the system time manually to ensure exact recording time.

---

**[Synchronized with your computer or modify manually]** Manually changes the GV-Compact DVR V3's date and time. Or, synchronize the GV-Compact DVR V3's date and time with those of the local computer.

**[Date and time overlay setting]** Select the display format of date and time stamps on the image. For this function to work, you must also enable the **Overlaid with date stamps** and **Overlaid with time stamps** options in Figure 6-2.

## 6.8.2 GPS Maps Settings

Note the GPS function is only supported on **Anti-Vibration ACC models** (GV-LX4C3V, GV-LX8CV1 and GV-LX8CV2).

The Anti-Vibration ACC models support the Global Position System (GPS) for active vehicle tracking and location verification. The vehicle location will be tracked on Google Maps. Before using the Google Maps, you must sign up for a Google Maps API key and enter the registered API key in the **Google Map API Key** field.

If your GV-Compact DVR V3 is equipped with a GPS device, it is not necessary to enter **Default Longitude** and **Default Latitude**, since its vehicle location will be tracked by GPS. However, if your GV-Compact DVR V3 is not equipped with a GPS device, you will need to enter **Default Longitude** and **Default Latitude** so that its location can be displayed correctly on the maps.

For details on the GPS application, see *8.3 GPS Tracking*.

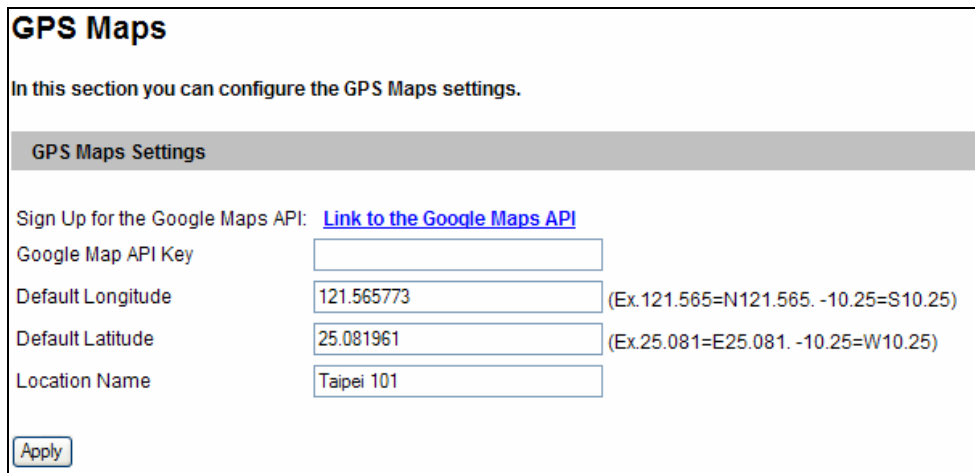

GPS Maps Settings	
Sign Up for the Google Maps API:	<a href="#">Link to the Google Maps API</a>
Google Map API Key	<input type="text"/>
Default Longitude	<input type="text" value="121.565773"/> (Ex. 121.565=N121.565. -10.25=S10.25)
Default Latitude	<input type="text" value="25.081961"/> (Ex. 25.081=E25.081. -10.25=W10.25)
Location Name	<input type="text" value="Taipei 101"/>

Figure 6-37

### 6.8.3 Storage Settings

You need to format the hard drive before using it for recording.

#### Storage Settings

In this section you can configure the disk storage to archive videos and events.

##### Storage Settings

Enable recycling

Stop recording or recycle disk when free space of disk is smaller than 5G ▼

Keep days (1-255) 30

Apply

##### Disk Information

Disk No.	Total Size	Used Size	Free space	Utilization	Remove	Format
Disk0	1862.852	125.388	1737.464	6%	<span style="border: 1px solid #ccc; padding: 2px 10px;">Remove</span>	<span style="border: 1px solid #ccc; padding: 2px 10px;">Format</span>

##### Partition Information

Disk No.	Partition No.	Total Size	Used Size	Free space	Utilization	Status	Format
Disk0	10	195.305	101.342	93.986	51%	OK	<span style="border: 1px solid #ccc; padding: 2px 10px;">Format</span>
Disk0	11	195.305	0.240	195.065	0%	OK	<span style="border: 1px solid #ccc; padding: 2px 10px;">Format</span>
Disk0	12	195.305	0.187	195.117	0%	OK	<span style="border: 1px solid #ccc; padding: 2px 10px;">Format</span>
Disk0	13	195.305	0.187	195.117	0%	OK	<span style="border: 1px solid #ccc; padding: 2px 10px;">Format</span>
Disk0	14	105.152	0.187	104.988	0%	OK	<span style="border: 1px solid #ccc; padding: 2px 10px;">Format</span>
Disk0	5	195.305	14.788	180.540	7%	OK	<span style="border: 1px solid #ccc; padding: 2px 10px;">Format</span>
Disk0	6	195.305	7.964	187.365	4%	OK	<span style="border: 1px solid #ccc; padding: 2px 10px;">Format</span>
Disk0	7	195.305	0.187	195.117	0%	OK	<span style="border: 1px solid #ccc; padding: 2px 10px;">Format</span>
Disk0	8	195.305	0.187	195.117	0%	OK	<span style="border: 1px solid #ccc; padding: 2px 10px;">Format</span>
Disk0	9	195.305	0.187	195.117	0%	OK	<span style="border: 1px solid #ccc; padding: 2px 10px;">Format</span>

(Unit: Gigabyte)

Figure 6-38

**To add a hard disk:**

1. Install the hard drive to the GV-Compact DVR V3.
2. Click the **Format** button.

After the format is complete, the partition information will be displayed.

**To remove a hard disk:**

1. Click the **Remove** button.
2. When you are prompted to ensure the action, click **Yes**. The page will be refreshed and the partition information will be cleaned.
3. Remove the hard drive from the GV-Compact DVR V3.

**[Storage Settings]**

If the **Enable recycling** option is selected, when the space of the hard drive is lower than the specified space, the system will either write the data to another device or overwrite the oldest recorded files.

If the **Enable recycling** option is cancelled, the system will stop recording when the specified space is reached.

**Keep days (1-255):** Specify the number of days to store the files from 1 day to 255 days.

When both **Keep days** and **Enable recycling** are selected, the system applies whichever condition comes first. For example, if the specified smallest amount of storage space comes earlier than the designated keep days, then recycle is applied first.

**[Disk Information]** This section shows the details of the hard drive.

**[Partition Information]** This section shows the partition details of the hard drive.

---

**Note:**

1. If **Enable Recycle** is selected, the available space of the hard drive must be higher than the space you specified at the **Stop recording or recycle disk when free space of disk is smaller than x** option. Otherwise no video will be recorded.
  2. The recording data may be lost if you remove the hard drive during recording.
  3. The storage device will be divided into three partitions after being formatted. Each partition has a maximum capacity of 200 GB.
  4. Currently 3 TB hard drive is not supported.
-

### 6.8.4 User Account

You can change the login name and password of Administrator, Guest and FTP Server User.

**[Administrator Account]** The default login name and password for Administrator are **admin**.

**[Guest User Account]** The default login name and password for Guest are **guest**.

#### **[Advanced Settings]**

- **Disable authentication for guest account:** Allows a Guest user to log in without entering a name and password on the Web interface of the Compact DVR V3.
- **Disable auto logout when reboot:** The option can prevent the automatic logoff of the current user after system restart.

**[FTP Server User Account]** The default login name and password to access the FTP server are **ftpuser**.

The screenshot shows a web interface titled "User Account". Below the title is a subtitle: "In this section you can change the administrator account and password". The interface is divided into four sections, each with a grey header bar:

- Administrator Account:** Contains input fields for "Username:" (pre-filled with "admin"), "Old Password:", "New Password:", and "Confirm Password:". Below these fields is an "Apply" button.
- Guest User Account:** Contains input fields for "Username:" (pre-filled with "guest"), "Old Password:", "New Password:", and "Confirm Password:". Below these fields is an "Apply" button.
- Advanced Setting:** Contains two checkboxes: "Disable authentication for guest account" and "Disable auto logout after reboot". Below these checkboxes is an "Apply" button.
- FTP Server User Account:** Contains input fields for "Username:" (pre-filled with "ftpuser"), "Old Password:", "New Password:", and "Confirm Password:". Below these fields is an "Apply" button.

Figure 6-39



## 6.8.5 Log Information

The **Startup time log** section contains every start time of the GV-Compact DVR V3. The startup time log is saved on the hard disk, so the log is only available when a hard disk is inserted to the GV-Compact DVR V3.

The **Debug Messages** section contains the dump data used by service personnel for analyzing problems. The log also records the task of log backup. You can back up the simplified system log by using the OSD menu. See *4.8.8 System Log*.

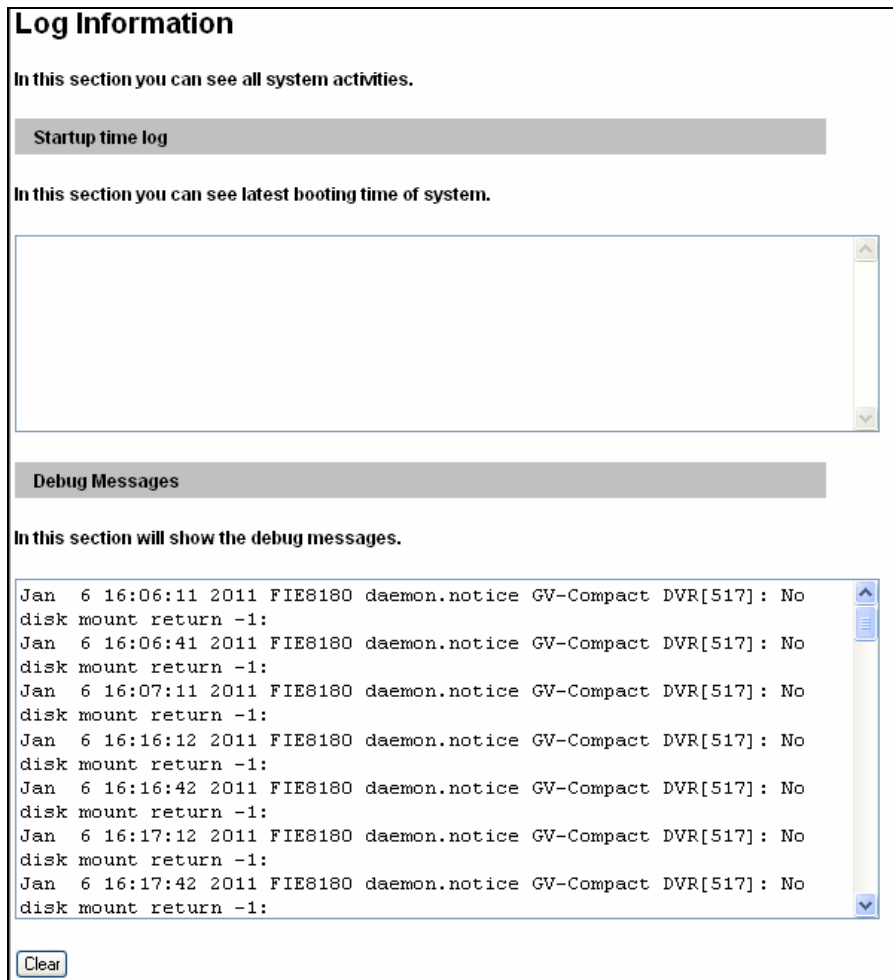

**Log Information**

In this section you can see all system activities.

**Startup time log**

In this section you can see latest booting time of system.

**Debug Messages**

In this section will show the debug messages.

```
Jan  6 16:06:11 2011 FIES180 daemon.notice GV-Compact DVR[517]: No
disk mount return -1:
Jan  6 16:06:41 2011 FIES180 daemon.notice GV-Compact DVR[517]: No
disk mount return -1:
Jan  6 16:07:11 2011 FIES180 daemon.notice GV-Compact DVR[517]: No
disk mount return -1:
Jan  6 16:16:12 2011 FIES180 daemon.notice GV-Compact DVR[517]: No
disk mount return -1:
Jan  6 16:16:42 2011 FIES180 daemon.notice GV-Compact DVR[517]: No
disk mount return -1:
Jan  6 16:17:12 2011 FIES180 daemon.notice GV-Compact DVR[517]: No
disk mount return -1:
Jan  6 16:17:42 2011 FIES180 daemon.notice GV-Compact DVR[517]: No
disk mount return -1:
```

Clear

Figure 6-40

## 6.8.6 Tools

This section allows you to execute certain system operations and view the firmware version.

### Additional Tools

In this section you can set the additional tools

---

#### Host Settings

In this section you can determine a hostname and camera name for identification.

Host Name

---

#### Auto Reboot Setup

In this section you can set the system's auto reboot time.

Enable

Day Interval  days

RebootTime  :

---

#### Repair Recording Database

Click Apply to repair the database when you cannot play back recordings.

---

#### Repairing Status

Unknown

---

#### Firmware Version

In this section you can see GV-Compact DVR firmware version.

---

#### System Settings

Restore to factory default settings

Current chipset temperature inside camera is  °C /  °F

---

#### Reboot

Do you wish to reboot now?

Figure 6-41

**[Host Settings]** Enter a descriptive name for the GV-Compact DVR V3.

**[Auto Reboot Setup]** Select **Enable** to activate automatic reboot and specify the time for reboot in the sub fields below.

- **Day Interval:** Type the day interval between reboots.
- **RebootTime:** Use the drop-down list to specify the time for automatic reboot.

**[Repair Recording Database]** Click **Apply** to repair the database when errors occur while playing back the recordings with the Remote ViewLog player.

**[Repairing Database]** This field displays the repairing progress. The field will display “Prepare to Repair”, “Repairing” or “Finish”.

---

**Note:** If the video files stored in the hard drives are already damaged, the database can not be successfully repaired.

---

**[Firmware Version]** This field displays the firmware version of the GV-Compact DVR V3.

**[System Settings]** Clicking the **Load Default** button will make the GV-Compact DVR V3 restore factory default settings. The Ready LED on the front panel will turn off. Wait until the Ready LED turns on and re-log in the unit.

This field also displays the current chipset temperature inside the GV-Compact DVR V3. Note this function is only available for **eight-channel GV-Compact DVR V3**.

---

**Note:** After applying the default function, you will need to configure the GV-Compact DVR V3's network setting again.

---

### **[Reboot]**

Clicking the **Reboot** button will make the GV-Compact DVR V3 perform software reset. The Ready LED on the front panel will turn off. Wait until the Ready LED turns on and re-log in the unit.

### 6.8.7 ACC Settings

Note the ACC setting is only supported on **Anti-Vibration ACC models** (GV-LX4C3V / GV-LX8CV1 / GV-LX8CV2).

The ACC setting allows you to specify power-off delay time from 0 to 30 minutes. The GV-Compact DVR V3 will not turn off for the specified delay time after you power off the vehicle.

**ACC Settings**

In this section you can configure the ACC settings.

**Power-off delay settings**

Select Power-off delay time (0-30 minutes)

Apply

Figure 6-42

## Chapter 7 Remote Recording and Playback

The Administrator can remotely start recording to the GV-Compact DVR V3 and play back the recorded files over the TCP/IP network.

### 7.1 Remote Recording

To remotely enable the recording function to the GV-Compact DVR V3:

1. Make sure the hard drive is installed in the unit. See *6.8.3 Storage Settings*.
2. If you like to set up the pre-recording, post-recording or audio recording, see *6.1.1 Video Settings*.
3. If you like to set up the schedule for video recording or I/O monitoring, see *6.5 Recording Schedule*.
4. If you like to configure the areas and sensitivity values for motion detection, see *6.1.2 Motion Detection*.
5. If you want the recording to be triggered by an input device, configure the operation of I/O devices. See *6.2.1 I/O Control*.
6. To start recording and I/O monitoring, see *6.4 Monitoring*.

The GV-Compact DVR V3 will start recording in case of motion detection, I/O trigger, or on the scheduled time.

### 7.2 Remote Playback

Several methods are available to access and play back the video files recorded on the GV-Compact DVR V3. This section will introduce the following playback methods:

- How to play back the files recorded on the hard drive
- How to play back files over network
- How to access the files through FTP Server
- How to play back the files backed up on a DVD disc or USB storage device
- How to play back the GPS tracks

### 7.2.1 Playback of Files Recorded on Hard Drive

You can play back the files recorded on the hard drive by connecting it to a computer or GV-System. However, the files recorded on the GV-Compact DVR V3 are of Linux file system. To enable Windows to recognize the files, you need to install the Ext2Fsd program, an ext2 file system driver for Windows, from the Software CD/DVD.

1. Insert the Software CD/DVD, select **Ext2 File System Driver** and follow the onscreen instructions for installation.
2. On your desktop, click **Start**, select **Programs**, locate the **Ext2Fsd** folder and select **Ext2 Volume Manager**. All the connected drives are shown.

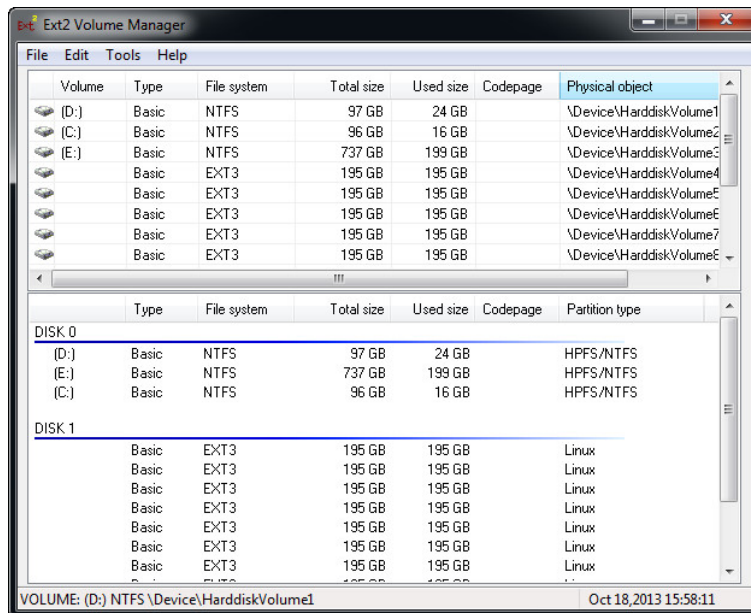
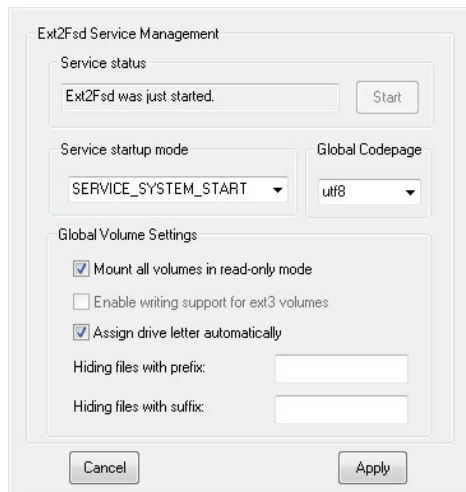

Figure 7-1

3. For the first-time installation, launch the Ext2Fsd Service.
  - a. From the Ext2 Volume Manager window, select **Tools** and select **Service Management**. This dialog box appears.



*Figure 7-2*

- b. Click **Apply**.
4. Mount the hard drive to your computer.
  - a. From the Ext2 Volume Manager window, right-click the hard drive and select **Ext2 Management**. This dialog box appears.

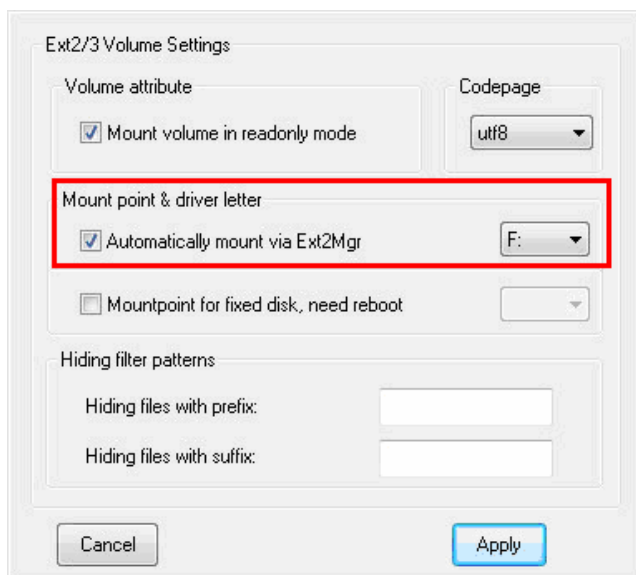

*Figure 7-3*

- b. Under the Mount point & driver letter section, select **Automatically mount via Ext2Mgr**, specify a disk drive using the drop-down list and click **Apply**.

## 7 Remote Recording and Playback

- c. On the Ext2 Volume Manager window, the hard drive is successfully mounted to your computer when it is indicated with the disk drive you specified.

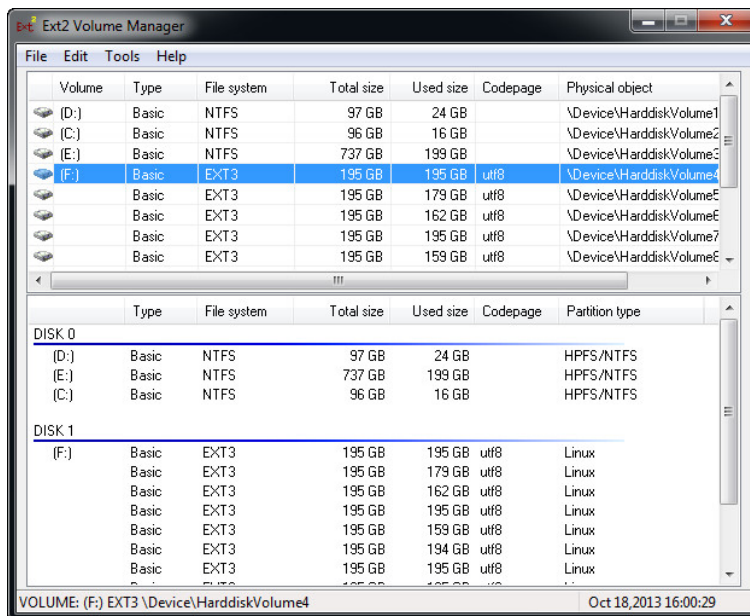



Figure 7-4

5. Access the recording files from the specified disk drive of your computer.
6. Run **ViewLog** from the GV-System.
7. Click the **Advanced** button , select **Reload Database** and click **Video Server/Compact DVR**. This dialog box appears.

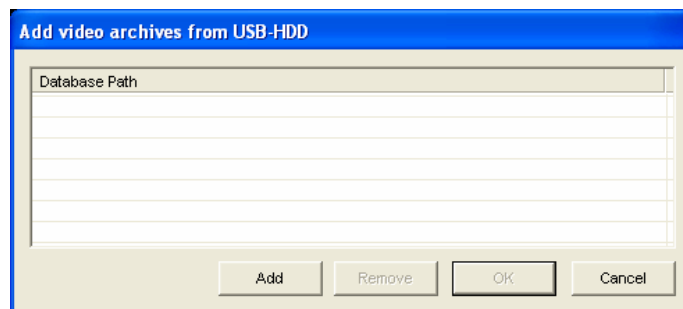

Figure 7-5

5. Click **Add** to assign the hard drive, and click **OK**.
6. After the Event List appears on the ViewLog or Remote ViewLog player, select the desired event for playback.



**Note:** Ext2Fsd program supports Windows 2000 / XP / 2003 / Vista / 7 / 8 / Server 2012 (32-bit and 64-bit). If you are using Windows 8 and Windows Server 2012, change its compatibility before installing the Ext2Fsd program:

- A. Right-click the Ext2Fsd program and select **Properties**. This dialog box appears.

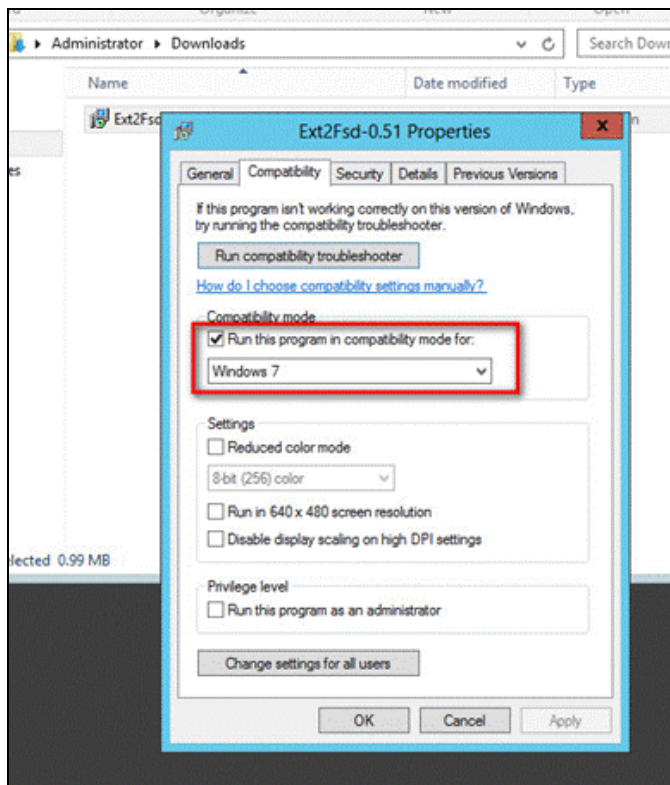

- B. Select the **Compatibility** tab.
- C. Select **Windows 7** using the drop-down list.

## 7.2.2 Playback over Network

You can remotely play back the files recorded on the GV-Compact DVR V3 over network.

1. The Administrator needs to allow the playback access with **ViewLog Server** activated. See 6.3.8 *ViewLog Server* to enable the server.
2. For the first-time user, install the **Remote ViewLog** program from the Software CD/DVD. Next time whenever you like to use the remote playback function on the same computer, access this option from the left menu of GV-Compact DVR V3's Web interface.
3. When the Remote ViewLog player is opened, you will be prompted to select Remote ViewLog Service or Remote Storage System. Select **Remote ViewLog Service**.
4. When this dialog box appears, type the IP address, login ID and password of the GV-Compact DVR V3. Keep the default port **5552** or modify it if necessary.

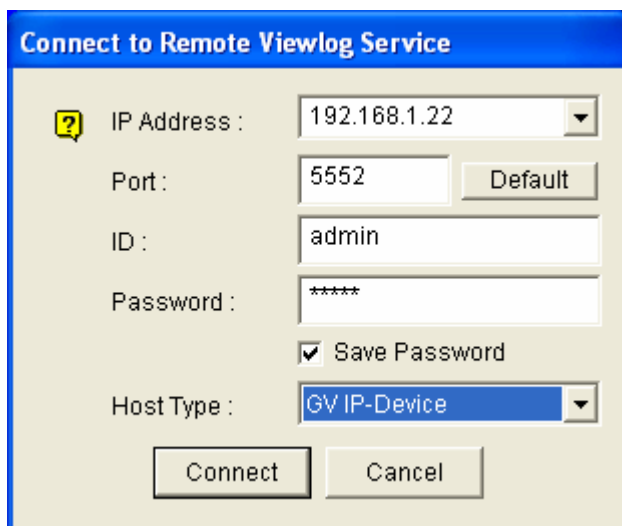

Figure 7-6

5. In the Host Type field, select **GV-IP Device**.
6. Click **Connect**.
7. After the Event List appears on the Remote ViewLog player, select the desired event for playback.

---

**Note:** For details on Remote ViewLog, see the supplementary user's manual on the Software CD/DVD.

---

### 7.2.3 Access to the Recorded Files through FTP Server

The built-in FTP server allows you to download the recorded files saved on the GV-Compact DVR V3.

1. Enable the FTP server. See [Act as FTP Server], 6.3.2 *FTP*.
2. To access the FTP server through a Web browser, enter the IP address or the domain name of the GV-Compact DVR V3 in your browser like this:  
  
ftp://192.168.0.10
3. When you are prompted for Username and Password, enter the default value **ftpuser** in both fields. After event triggers, the recorded files will be uploaded to the server.

You can play back the video files using Windows Media Player. You can also install the Remote Playback player from the Software CD/DVD for playback.

---

**Note:** To play back video, ensure you have installed GeoVision codec on the computer. The codec is available on the Software CD/DVD. If you have installed the Remote Playback player on the computer, it is not required to install the codec.

---

### 7.2.4 Playback of Backup Files

You can play back the video files backed up on a DVD disc or a USB storage device using Windows Media Player. You can also install the Remote Playback player from the Software CD/DVD for playback.

---

**Note:**

1. For how to back up the video files, see 4.8.9 *Backup*.
  2. To play back video, ensure you have installed GeoVision codec on the computer. The codec is available on the Software CD/DVD. If you have installed the Remote Playback player on the computer, it is not required to install the codec.
-

## 7 Remote Recording and Playback

To play back video using the Remote Playback player:

1. Install and run the **Remote Playback** player from the Software CD/DVD.
2. When the Remote ViewLog player is opened, you will be prompted to select Remote ViewLog Service or Remote Storage System. Select **Remote ViewLog Service**.
3. Click the **Advanced** button , select **Reload Database** and click **Video Server/Compact DVR**. This dialog box appears.

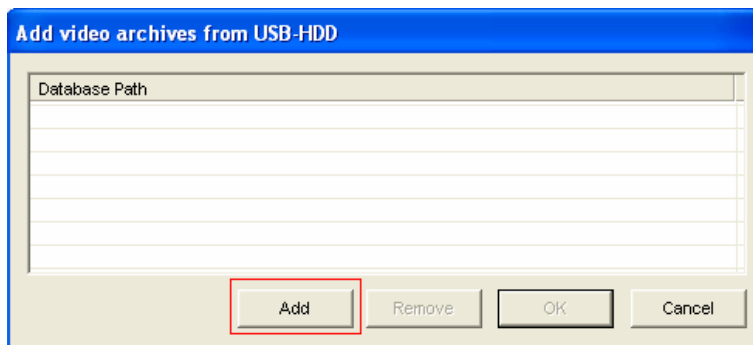

Figure 7-7

4. Click **Add**, and locate the DVD drive or USB storage device. Click **OK** to read the data.

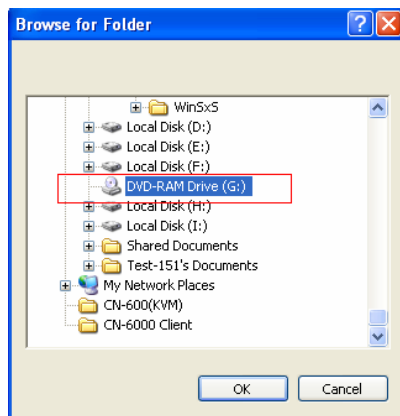

Figure 7-8

5. This dialog box appears. Click **OK**.

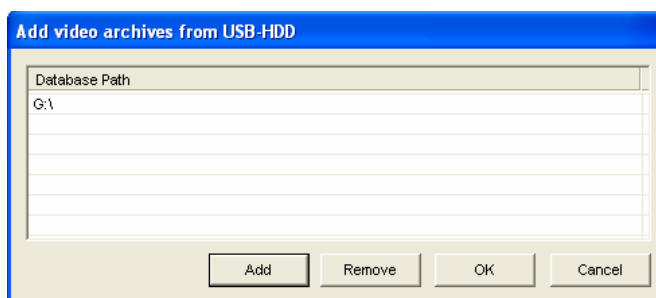
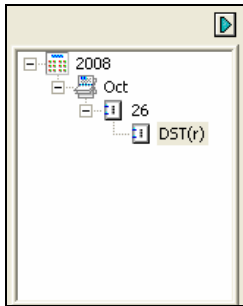

Figure 7-9

6. The Event List appears on the player. Select the desired event for playback.

---

**Note:** The AVI file recorded during the Daylight Saving Time (DST) period is named with the prefix “GvDST”, e.g. GvDST20081022xxxxxxxx.avi, to differentiate from the regular AVI file named with the prefix “Event”, e.g. Event20081022xxxxxxxx.avi. In the Event List of the Remote ViewLog player, you can also see the separate DST subfolder.



---

## 7.2.5 Playback of GPS Tracks

This function is only available for the Anti-Vibration ACC models (GV-LX4C3V / GV-LX8CV1 / GV-LX8CV2).

After the GPS function is enabled on the GV-Compact DVR V3, the GPS data will be recorded along with the video files. You can back up the video files on a DVD disc or a USB storage device and play back the GPS tracks on the maps.

---

**Note:**

1. For how to back up the video files, see [4.8.9 Backup](#).
2. You can also remotely access the GV-Compact DVR V3 using a Web browser, and use the Remote Playback function on the left menu of the Web interface for GPS track playback. For how to access the GV-Compact DVR 3 remotely, see [7.2.2 Playback over Network](#).

---

To play back the backup GPS tracks:

1. Install and run the **Remote Playback** player from the Software CD/DVD.
2. When the Remote ViewLog player is opened, you will be prompted to select Remote ViewLog Service or Remote Storage System. Select **Remote ViewLog Service**.

## 7 Remote Recording and Playback

- To select a map API (Application Program Interface), click the **Tools** button and click **Select Map API**. This dialog box appears.

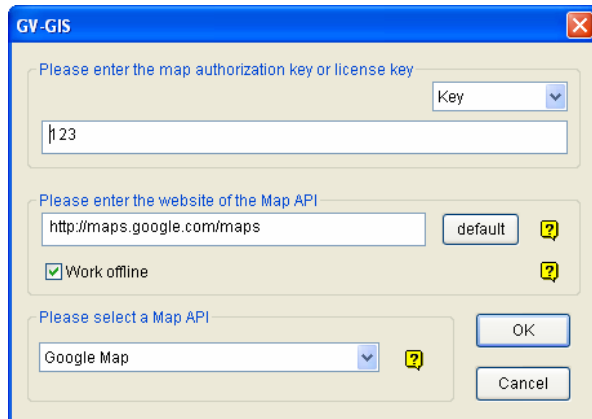

Figure 7-10

- In **Please Select a Map API**, select a Map API. For Google Maps, you need to sign up for an API key from Google website (<http://code.google.com/apis/maps/signup.html>), and enter the API key in the **Please enter the map authorization key or license key** field.
- To play back GPS tracks, click the **Tools** button and select **Display GIS Window**. The first-time user will be prompted for a License Agreement. Read through the license terms before you click **I understand and agree** to continue.
- Select the events of tracking routes from the Video Event list, select the desired video mode, and click the **Play** button to start.



Figure 7-11

---

**Note:**

1. The playback function is only compatible with GV-System version 8.3 or later.
  2. If you like to use the maps created yourself, overwrite the files at  
:\GV folder\GIShtm-User, and select **User Defined** from the “Please Select a Map API”  
drop-down list (Figure 7-7).
  3. If you are the paid-client of Google Maps, select **Client** from the “Please enter the map  
authorization key or license key” drop-down list; otherwise select **Key**.
-

# Chapter 8 Advanced Applications

This chapter introduces more advanced applications.

## 8.1 Upgrading System Firmware

GeoVision will periodically release the updated firmware on the website. The new firmware can be simply loaded into the GV-Compact DVR V3 over the network or by using the IP Device Utility included in the Software CD/DVD.

### Important Notes before You Start

Before you start updating the firmware, please read these important notes:

1. While the firmware is being updated, the power supply must not be interrupted.
2. Do not turn the power off for 10 minutes after the firmware is updated.

---

**WARNING:** The interruption of power supply during updating causes not only update failures but also damages to the device. In this case, please contact your sales representative and send your device back to GeoVision for repair.

---

**IMPORTANT:** After upgrading the firmware of GV-Compact DVR V3 to the latest version, it is required to **format the storage device** for better recording efficiency and stability. To format the storage device, be sure to back up the data first and see *3.7 Formatting Hard Drive* for how to format the storage device.

---



## 8.1.1 Using the Web Interface

1. In the Live View window, click the **Show System Menu** button (No. 12, Figure 5-6), select **Remote Config**, and click the **Firmware Upgrade** tab. This dialog box appears.

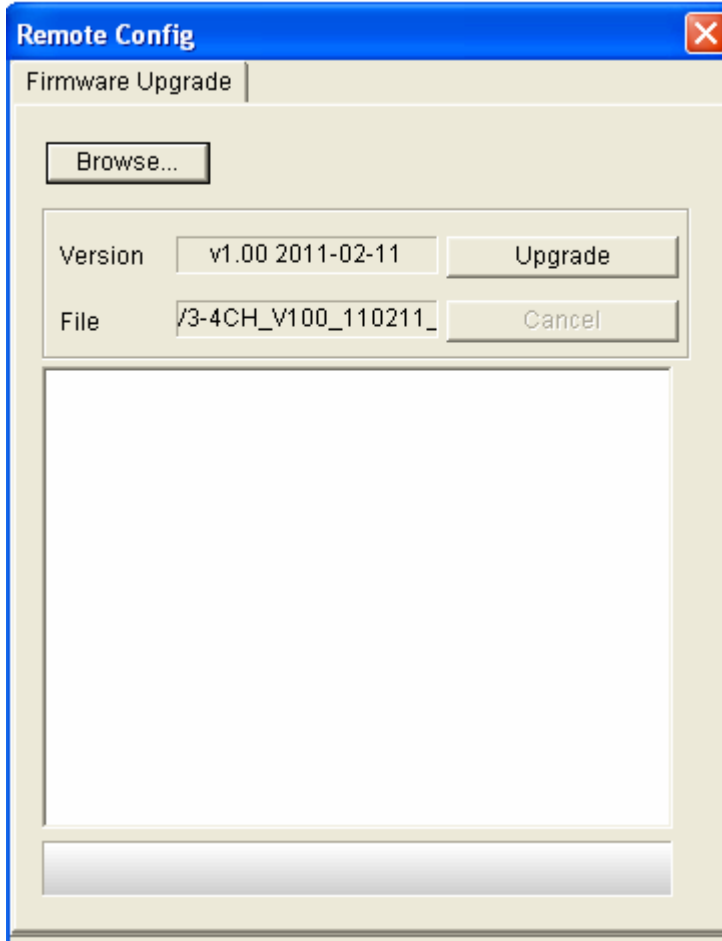

Figure 8-1

2. Click the **Browser** button to locate the firmware file (.img) saved at your local computer.
3. Click the **Firmware Upgrade** button to start upgrading.

### 8.1.2 Using the IP Device Utility

The IP Device Utility provides a direct way to upgrade the firmware to multiple units of the GV-Compact DVR V3.

1. Insert the Software CD/DVD, select **IP Device Utility**, and follow the onscreen instructions to install the program.
2. Double-click the **IP Device Utility** icon created on your desktop. This dialog box appears.

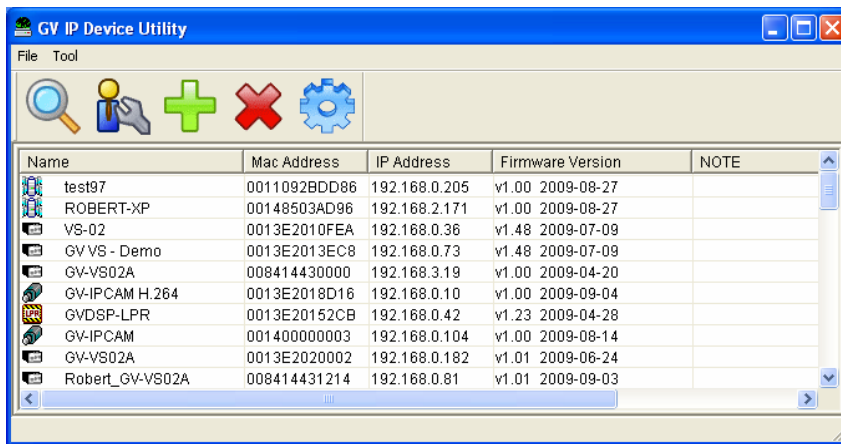



Figure 8-2

3. Click the **Search** button  to locate the available GV-Compact DVR V3 on the same LAN. Or click the **New** button and assign the IP address to locate a GV-Compact DVR V3 over the Internet. Or highlight one GV-Compact DVR V3 in the list and click the **Delete** button to remove it.
4. Double-click one GV-Compact DVR V3 in the list. This dialog box appears.

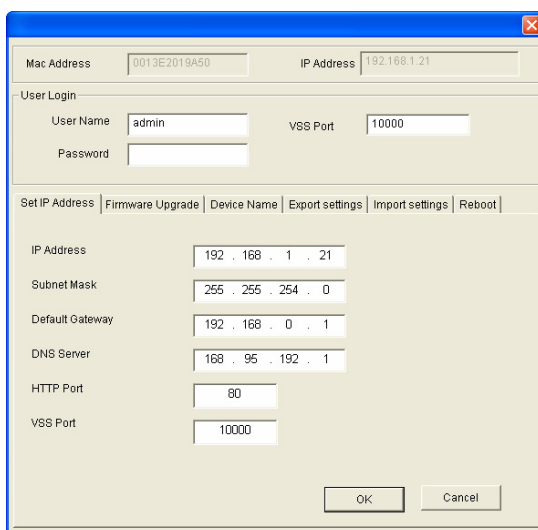
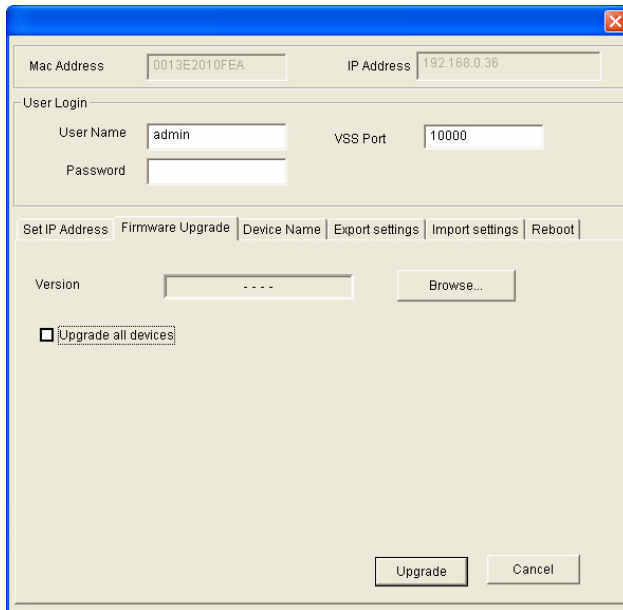

Figure 8-3

5. Click the **Firmware Upgrade** tab. This dialog box appears.



*Figure 8-4*

6. Click the **Browse** button to locate the firmware file (.img) saved at your local computer.
7. If you like to upgrade all the GV-Compact DVR V3s in the list, select **Upgrade all devices**.
8. Type **Password**, and click **Upgrade** to process the upgrade.

## 8.2 Backing Up and Restoring Settings

With the IP Device Utility included in the Software CD/DVD, you can back up the configurations in the GV-Compact DVR V3 and restore the backup data to the current unit or import it to another unit.

### 8.2.1 Backing Up the Settings

1. Run **IP Device Utility** and locate the desired GV-Compact DVR V3. See Steps 1-3 in *8.1.2 Using the IP Device Utility*.
2. Double-click the GV-Compact DVR V3 in the list. Figure 8-3 appears.
3. Click the **Export Settings** button. This dialog box appears.

Figure 8-5

4. Click the **Browse** button to assign a file path.
5. Type **Password**, and click **Export Settings** to save the backup file.

## 8.2.2 Restoring the Settings

1. In Figure 8-3, click the **Import Settings** tab. This dialog box appears.

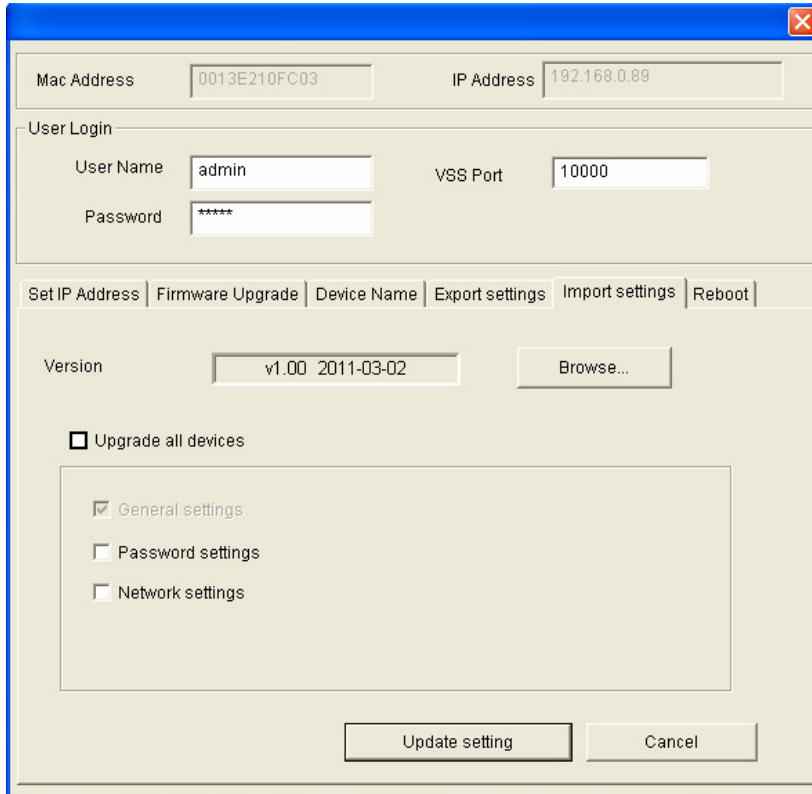

*Figure 8-6*

2. Click the **Browse** button to locate the backup file (.dat).
3. Select **Password Settings** to restore the password settings, if necessary.
4. Select **Network Settings** to restore the network setting, if necessary.
5. Click **Update Setting** to start restoring.

### 8.3 GPS Tracking

The Anti-Vibration ACC models of the GV-Compact DVR V3 support the Global Position System (GPS) for active vehicle tracking and location verification. The vehicle location will be tracked by Google Maps.

To track the location of your GV-Compact DVR V3:

1. Connect the GV-GPS module with PS/2 connector to the GPS port on the rear panel of the unit.
2. Enable the GPS function. See 4.2.3 *GPS Settings* for OSD menu configurations, or 6.2.3 *GPS* for web-based configurations.
3. Sign up for a Google Maps API Key and enable the GPS Maps settings. See 6.8.2 *GPS Maps Settings*.
4. Open the control panel of the Live View window.

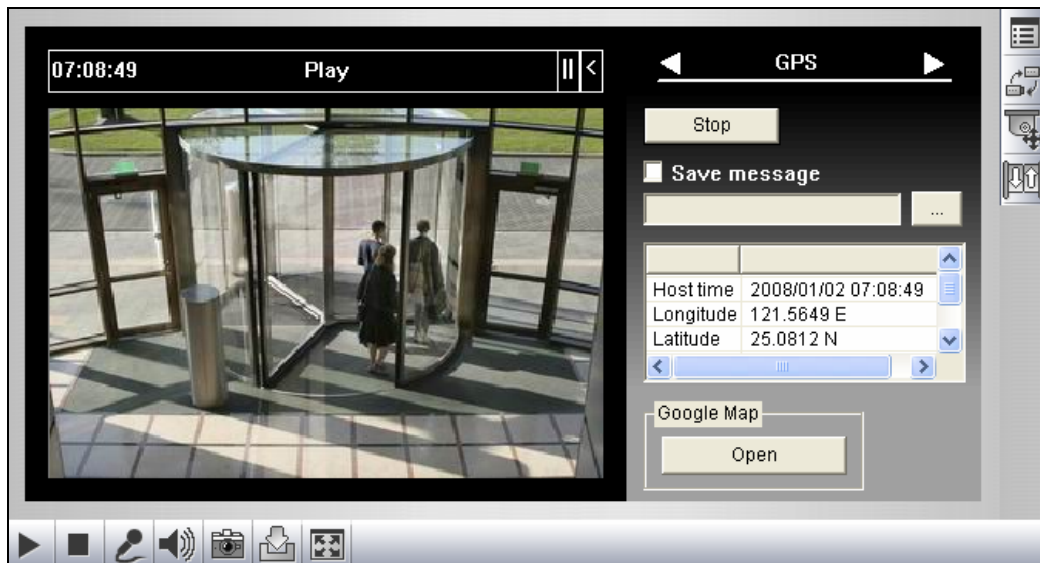

Figure 8-7

- Click Start to activate GPS tracking. The longitude, latitude and host time of the GV-Compact DVR V3 will be displayed.
- To save the location information to your local computer, select Save message and click [...] to assign the storage path.

- To track the GV-Compact DVR V3 on Google Maps, click Open. A warning message appears.

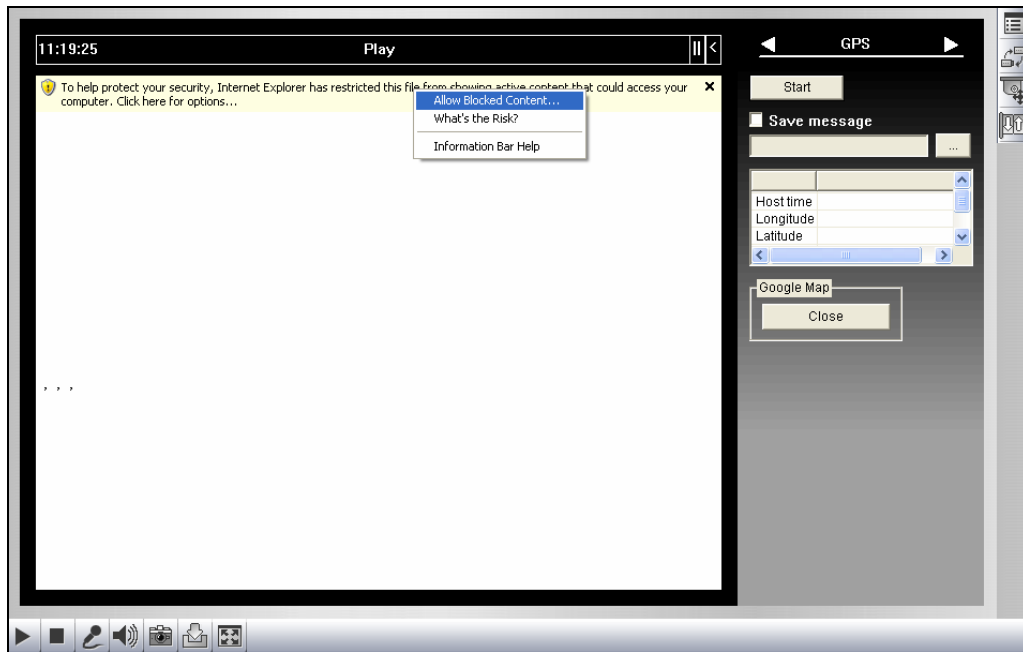

Figure 8-8

- Right-click the warning message and select Allow Blocked Content. The map will be displayed. The  icon indicates the location of your GV-Compact DVR V3. At the upper right corner you have options to view different map formats, such as Satellite and Hybrid.



Figure 8-9

## 8.4 Restoring to Factory Default Settings

To restore the GV-Compact DVR V3 to default settings, use the **Reset** and **Default** buttons on the front panel. For the location of the two buttons see *2.1 Front Panel*.

1. Press and then release the **Reset** button immediately.
2. Press and hold the **Default** button until the 2 LEDs (Power and Ready) are on. This may take up to 30 seconds.
3. Release the **Default** button. The process of loading default values is complete, and the GV-Compact DVR V3 starts rebooting itself with Ready LED turning off.
4. Wait until the Power and Ready LEDs turn on again. After this, all the settings are returned to default values.

---

**Note:** Before the **Ready LED** is on again, do not unplug the power cable; otherwise the loading of default values will fail.

---



## 8.5 Verifying Watermark

The watermark is an encrypted and digital signature embedded in the video stream during the compression stage, protecting the video from the moment of creation. Watermarking ensures that an image is not edited or damaged after it is recorded. To enable the watermark function, see [Watermark], *6.1.1 Video Settings*.

The **Watermark Proof** is a watermark-checking program. It can verify the authenticity of the recording before you present it in court.

### 8.5.1 Accessing the Recorded Files

To verify watermark, you must obtain the recorded files by one of these methods first.

1. Use the **File Save** function on the Live View window (Figure 5-6) to start recording on the local computer.
2. Use the **Act as FTP Server** function to download the files from the GV-Compact DVR V3. See *6.3.2 FTP*.
3. Use the files recorded on the hard drive. Since the files saved on the hard drive are of Linux file system, you need to run **Ext2Fsd** program to convert the Linux-based files to Windows-based files. For the instructions, see Steps 1 to 5 in *7.2.1 Playback of Files Recorded on Hard Drive*.
4. Back up the files to a DVD disc or a USB storage device. For how to back up files, see *4.8.9 Backup*.

### 8.5.2 Running Watermark Proof

1. Install **Watermark Proof** from the Software CD/DVD. After installment, a **WMProof** icon is created on your desktop.
2. Double-click the created icon. The Water Mark Proof window appears.
3. Click **File** from the menu bar, select **Open** and locate the recorded file (.avi). The selected file is then listed on the window. Alternatively, you can drag the file directly from the storage folder to the window.
4. If the recording is unmodified, a check mark will appear in the **Pass** column. On the contrary, if the recording is modified or the Watermark function is not enabled, a check mark will appear in the **Failed** column. To play back the recording, double-click the listed file on the window.

### 8.5.3 The Watermark Proof Window

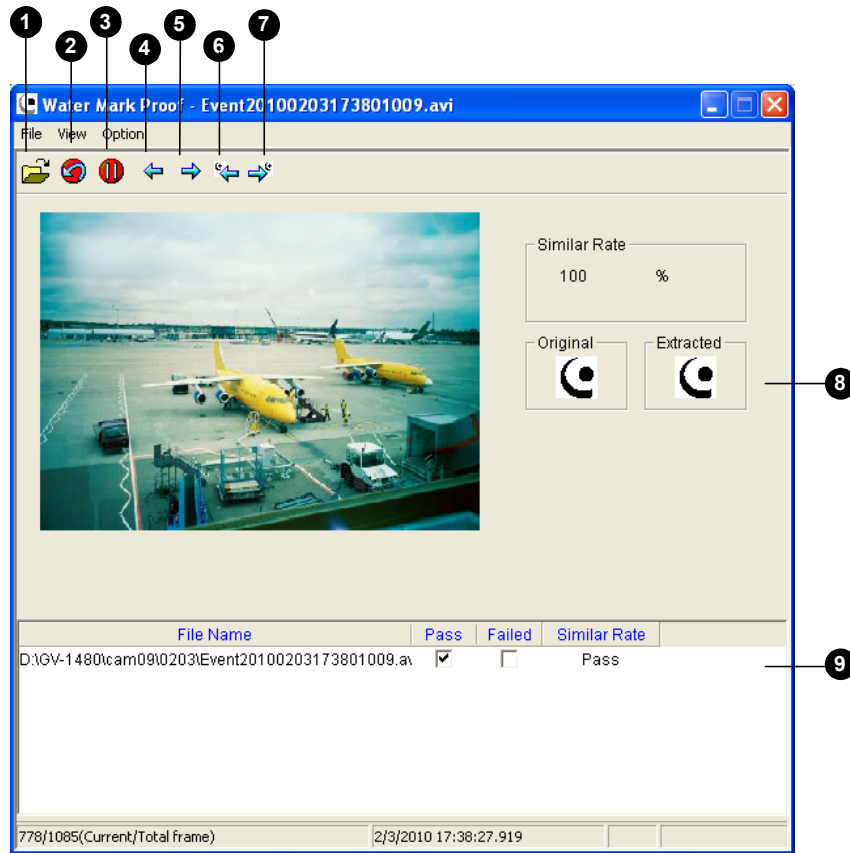

Figure 8-10

The controls in the window:

No.	Name	Description
1	Open File	Opens the recorded file.
2	First Frame	Goes to the first frame of the file.
3	Play	Plays the file.
4	Previous Frame	Goes to the previous frame of the file.
5	Next Frame	Goes to the next frame of the file.
6	Previous Watermarked Frame	Goes to the previous frame that contains watermark.
7	Next Watermarked Frame	Goes to the next frame that contains watermark.
8	Original vs. Extracted	The Extracted icon should be identical with the Original icon. If not, it indicates the recording has been tampered.
9	File List	Displays the proof results.

## Chapter 9 Smart Device Surveillance

Using an Android or Apple device you can receive live video streaming from the GV-Compact DVR V3. The chart below lists the available remote viewers for GV-Compact DVR V3.

Handheld Device Viewer	Resolution and Codec Supported		OS Supported	Default Port	Features
<b>GV-Eye / GV-Eye HD</b>	H.264	2M (1920 x 1080) or lower	- iOS 4.3.3 to 7.0.4 - Android version 2.2 to 4.3	VSS Port: 10000	Live view, Snapshots, I/O Trigger, PTZ control & Presets, One-way Audio, Multiple Camera View

Chart 1

---

**Note:** GV-Eye / GV-Eye HD does not support remote playback from the GV-Compact DVR V3.

---

## 9.1 Android Smartphones and Tablets

Using the **GV-Eye** application on Android devices, you can remotely view live video, take snapshot and start and stop monitoring.

---

**Note:** For the latest specifications and instructions of the latest version, see the *GV-Eye for Android Smartphones & Tablets Installation Guide* on our website:

[http://www.geovision.com.tw/upload/en/mobileap/GV-Eye\\_AndroidV130.pdf](http://www.geovision.com.tw/upload/en/mobileap/GV-Eye_AndroidV130.pdf)

---

### Installing GV-Eye

Download **GV-Eye** from Android Market, and after installing the application, the GV-Eye icon will appear on the desktop.

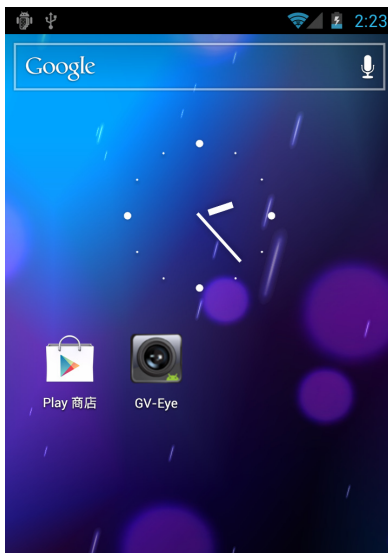



Figure 9-1

## 9.1.1 Connecting to GV-Compact DVR V3

To connect to GV-Compact DVR V3, follow these steps:

1. Tap the **GV-Eye** icon  on you mobile phone.
2. In the address book, tap the **Add** button to add a GV-Compact DVR V3.

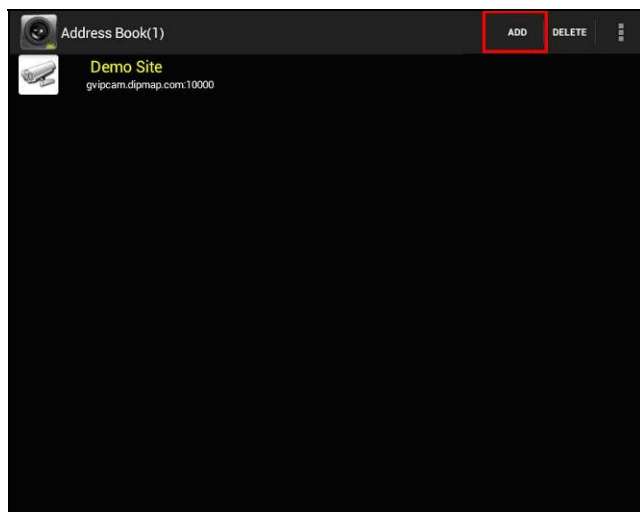

Figure 9-2

3. Type the IP address, port number (default value is 10000), user name and password of the GV-Compact DVR V3 you want to access.

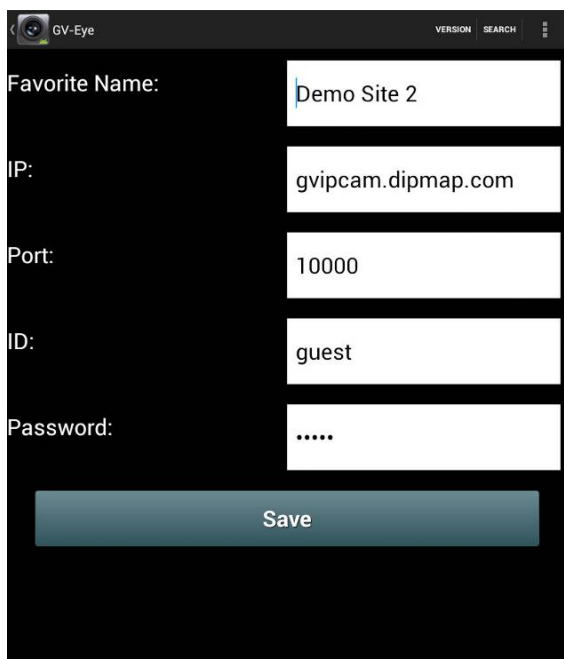

Figure 9-3

4. Click **Save** to add the GV-Compact DVR V3.

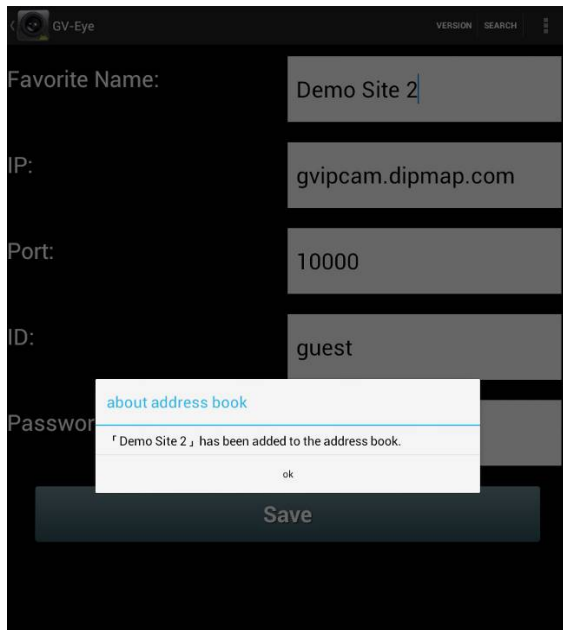

Figure 9-4

5. Click **ok**. The GV-Compact DVR V3 is added to the address book.

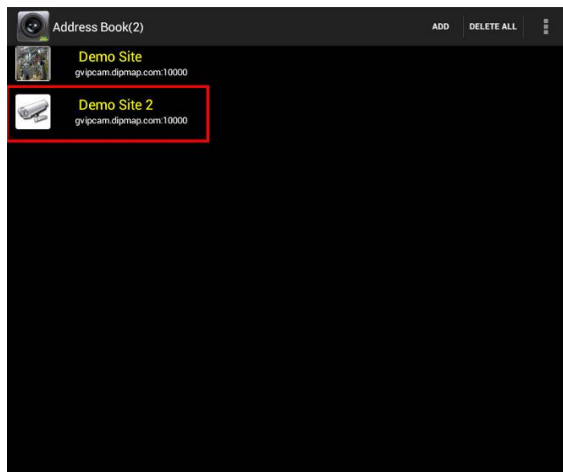

Figure 9-5

6. In the address book, tap the GV-Compact DVR V3 to access the live view.

## 9.2 iPhone, iPod Touch and iPad

Using the **GV-Eye / GV-Eye HD** application on iPhone, iPod Touch or iPad, you can remotely view live video, take snapshot and start and stop monitoring. GV-Eye is designed for iPhone and iPod Touch, while GV-Eye HD is designed for iPad.

---

**Note:** For the latest specifications and instructions of the latest version, see the *GV-Eye for iPhone and iPod Touch / GV-Eye HD for iPad Installation Guide* on our website:

<http://www.geovision.com.tw/upload/en/mobileap/GV-EyeV130.pdf>

---

### Installing GV-Eye / GV-Eye HD

You can download GV-Eye / GV-Eye HD from **App Store** and install the application. The GV-Eye / GV-Eye HD icon will appear on the desktop.

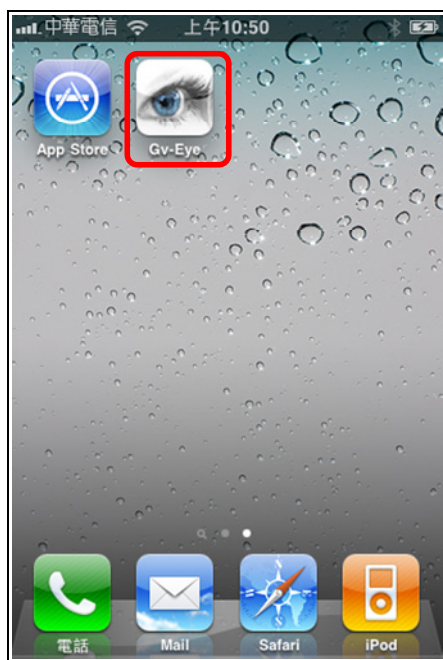

GV-Eye icon on iPhone / iPod Touch

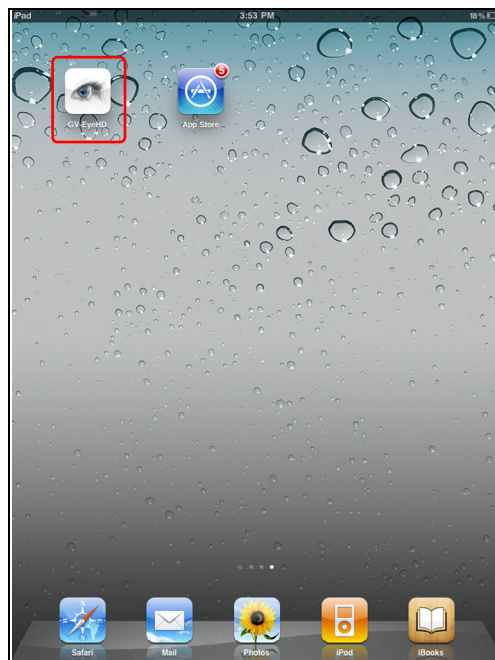



GV-Eye HD icon on iPad

Figure 9-6

## 9.2.1 Connecting to GV-Compact DVR V3

To connect your iPhone, iPod Touch and iPad to GV-Compact DVR V3, follow these steps:

1. Click the **GV-Eye** icon  on the desktop of your phone. The welcome page appears.
2. Tap the **Add** button . This page appears.

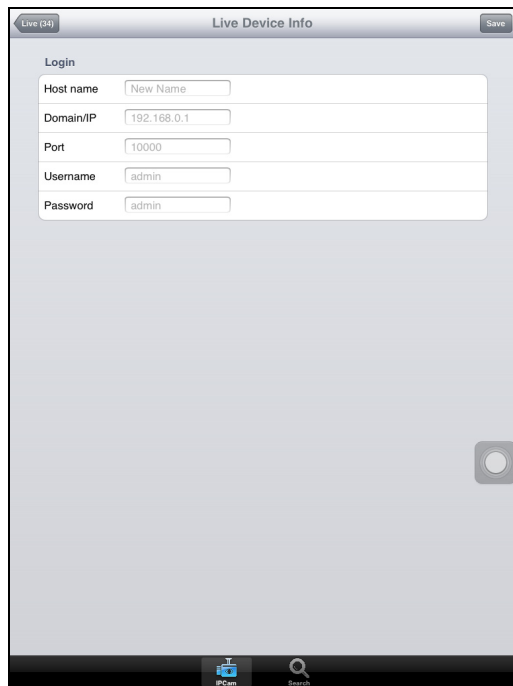

Figure 9-7

3. Enter the Host name, Domain/IP address, port number (default value is 10000), username and password to log in to the GV-Compact DVR V3.



4. Tap the **Save** button. The GV-Compact DVR V3 is added to the connection list.

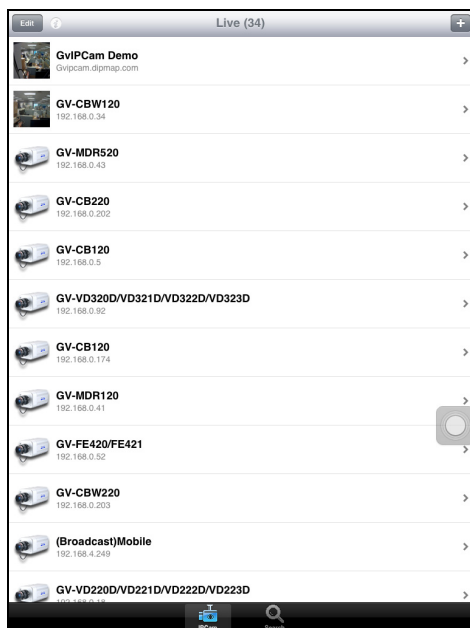

Figure 9-8

5. In the connection list, tap the host name to access the live view.

## Chapter 10 DVR Configurations

The GV-System provides hybrid solution, integrating the digital videos from GV-Compact DVR V3 with other analog videos. For the digital videos, the GV-System provides the complete video management, such as video viewing, recording, playback, alert settings and almost every feature of the system. Note the following integration specifications:

- GV-System version **8.4 with a patch** or later version is required.
- The maximum number of streams that a GV-Compact DVR V3 allows is 8 (4-channel models) / 9 (8-channel models). When a channel of GV-Compact DVR V3 is connected to GV-System, IE browser or any other application, it takes up 1 stream.

---

**Note:** When you connect over the maximum number of streams specified above, a warning message “Too many users” will pop up, and no image can be accessed after the threshold.

---

- The recording resolution of digital videos is set up on the GV-Compact DVR V3 instead of on the GV-System.
- The hardware compression and the “Pre-Recording Using RAM” feature cannot work on the videos from the GV-Compact DVR V3.

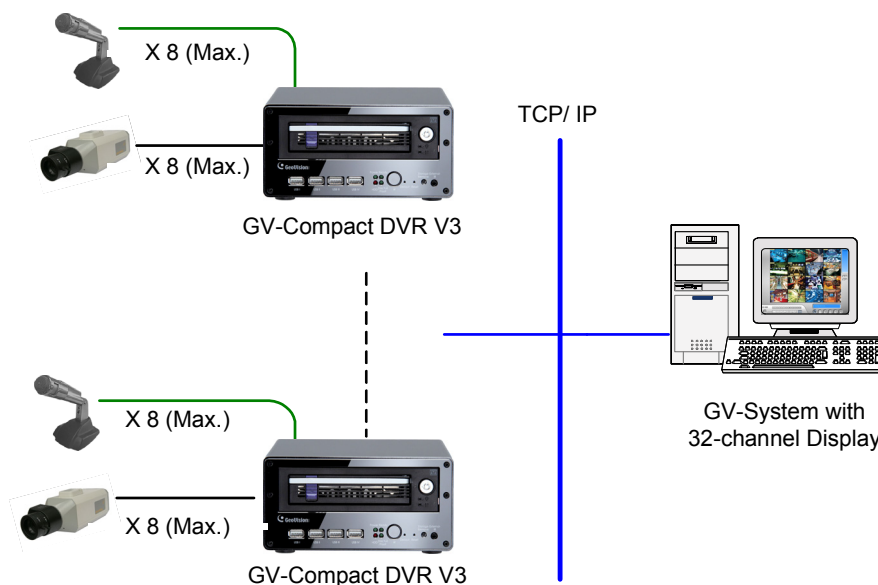
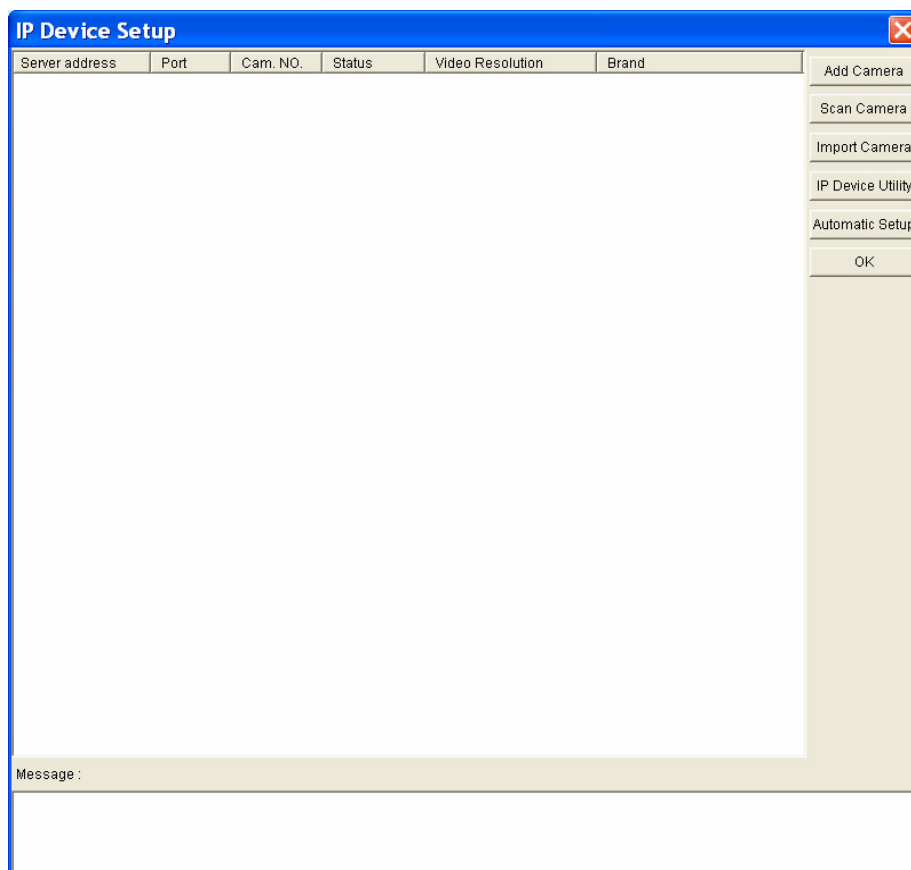

Figure 10-1

## 10.1 Setting up GV-Compact DVR V3

To set up a GV-Compact DVR V3 on the GV-System, follow these steps:

1. On the main screen, click the **Configure** button, select **System Configure**, select **Camera Install** and click **IP Camera Install**. This dialog box appears.



*Figure 10-2*

- To automatically set up a GV-Compact DVR V3, click **Scan Camera** to detect any GV-Compact DVR V3 devices on the same LAN.
- To manually set up a GV-Compact DVR V3, click **Add Camera**.

The following steps are the example of manual setup.

2. Click **Add Camera**. This dialog box appears.

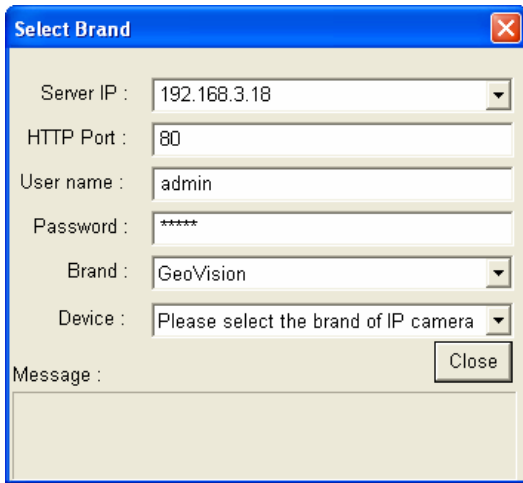

Figure 10-3

3. Type the IP address, username and password of the GV-Compact DVR V3. Modify the default HTTP port if necessary.
4. Select **GeoVision** from the **Brand** drop-down list and select **GeoVision Compact DVR** from the **Device** drop-down list. This dialog box appears.

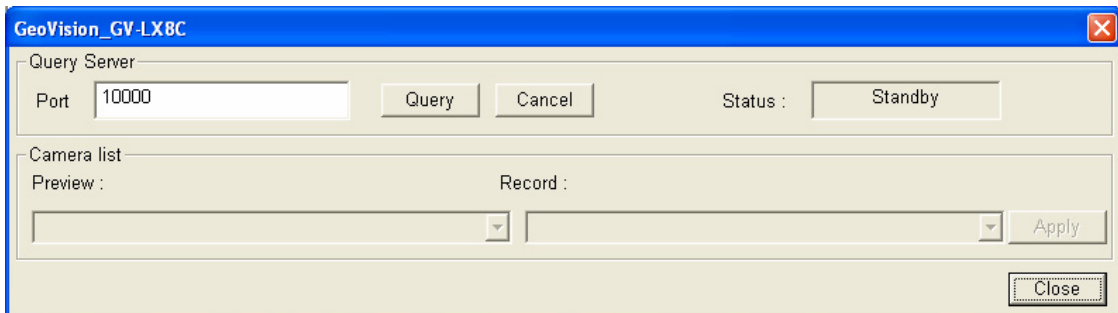
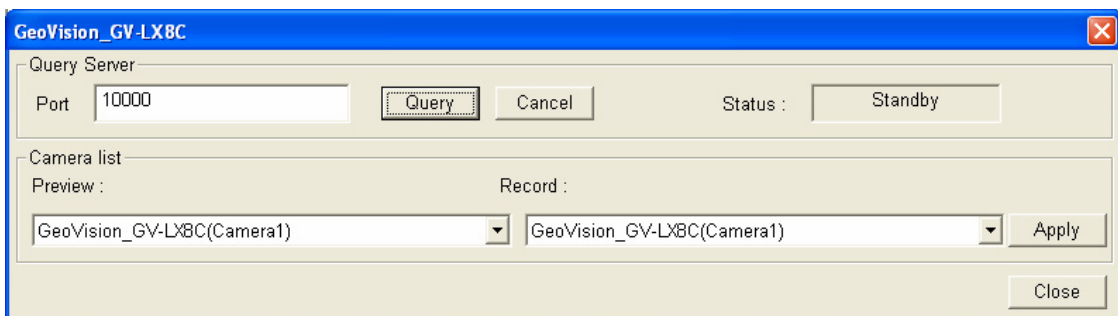

Figure 10-4

5. Click **Query** to detect the GV-Compact DVR V3. When it is detected, its available camera options will be displayed in the Camera List section.



6. Select the camera for live view from the **Preview** drop-down list, and the camera for recording from the **Record** drop-down list.

- Click **Apply**, and then **Close** to exit the dialog box. The device information is displayed.

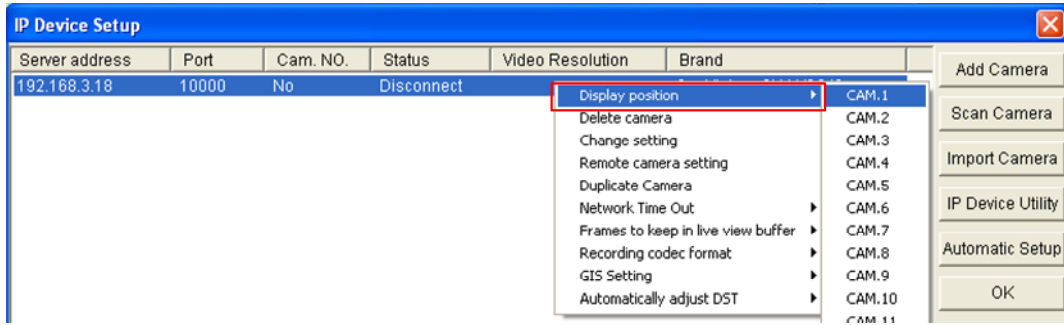

Figure 10-5

- Right-click the device information and select **Display Position** to map the IP camera to a channel on the GV-System.
- The Statue column now should display “Connected”. Click **OK**.

### Configuring the Compact DVR Settings

After the GV-Compact DVR V3 is connected and assigned with a display position, you can configure settings such as frame rate, codec type and resolution. Right-click the GV-Compact DVR V3 on the IP Device Setup dialog box to see the following list of options:

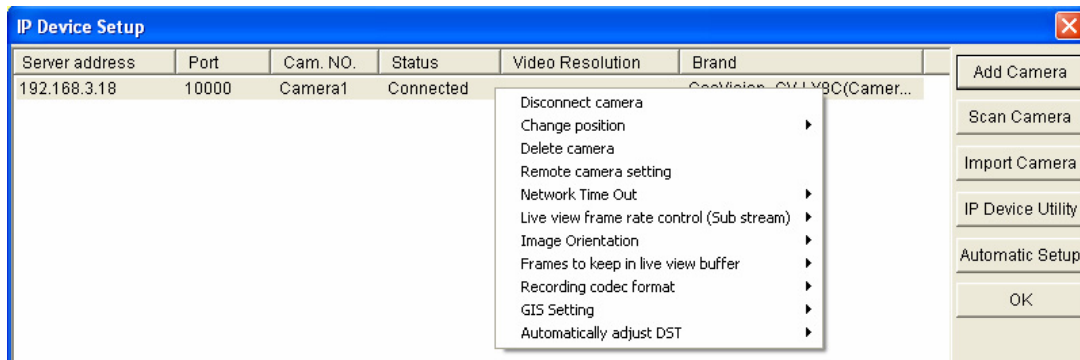

Figure 10-6

- **Network Time Out:** When network disconnection exceeds the specified time period, the camera status will be displayed as Connection Lost.
- **Frames to keep in live view buffer:** Specifies the number of frames to keep in the live view buffer.
- **GIS Setting:** Records the video with the GPS data. To record the GPS data, remember to also enable the GIS function of the GV-System (**Configure** button < **Accessories** < **Enable Local GIS**).

- **Automatically Adjust DST:** If enabled, the time on the GV-Compact DVR V3 Web interface will be synchronized with the time of the GV-System when DST period starts or ends on the GV-System.

## 10.2 Remote Monitoring with Multi View

You can use the Multi View to monitor and manage the cameras and I/O devices connected to the GV-Compact DVR V3.

### Connecting to GV-Compact DVR V3

The Multi View program is available in the GV-System applications, and also included in the Software CD/DVD as an independent program. The following is an example of running the Multi View through WebCam Server on the GV-System.

1. To enable the remote access to the GV-System, click the **Network** button, select **WebCam Server** to display the Server Setup dialog box, and click **OK** to start the WebCam server.
2. At the local computer, open the Web browser and type the address of the GV-System. The Single View page appears.
3. Select **Multi View** and the desired viewing resolution. The valid user name and password are required for login. For the first-time user, you will be directed to the Download page. Install the Multi View program before you can run it.
4. On the Multi View window, click the **Edit Host** button. The Edit Host window appears.
5. To create a host, click the **New** button. You need to create a group before creating a host.

6. Select **Compact DVR** from the Device drop-down list. Type the host name, IP address, user name and password of the GV-Compact DVR V3. Modify the default VSS port **10000** if necessary.

The screenshot displays a software interface for configuring a DVR. It is divided into two main sections: 'Host List' on the left and 'Host Informations' on the right. The 'Host List' section contains a tree view with 'New Group' and 'Compact DVR' under it, and buttons for 'New', 'Delete', 'Export', and 'Import'. The 'Host Informations' section includes a 'Host Protection' checkbox, a 'Host Name' field with 'Compact DVR', a 'Device' dropdown menu set to 'Compact DVR', and input fields for 'IP Address' (192.168.1.21), 'User Name' (admin), 'Password' (masked with asterisks), and 'VSS Port' (10000). A 'Save' button is located at the bottom right of the 'Host Informations' section, and an 'OK' button is at the bottom right of the entire window.

Figure 10-7

7. Click **Save** to establish connection.

For details on the Multi View functions, see “Multi View Viewer”, *Chapter 8 Remote Viewing, DVR User’s Manual* on the Surveillance System Software CD/DVD.



## 10.3 Remote Monitoring with E-Map

You can use the Remote E-Map to monitor and manage the cameras and I/O devices connected to the GV-Compact DVR V3.

### Creating an E-Map for GV-Compact DVR V3

With the E-Map Editor, you can create an E-Map for the cameras and I/O devices connected to the GV-Compact DVR V3. The E-Map Editor is available in certain applications, e.g. Main System and E-Map Server. The following is an example of running the E-Map Editor included in the Main System.

1. Go to Windows **Start** menu, point to **Programs**, select **GV folder** and click **E-Map Editor**.
2. To create an E-Map, click the **Add Map** button on the toolbar. A New Map file appears.
3. Double-click the New Map file, and click the **Load Map** button on the toolbar to import a graphic file.
4. To create a host, click the **Add Host** button on the toolbar and select **Add Compact DVR**.
5. Right-click the created New Host in the Host View, and select **Host Settings**. This dialog box appears.

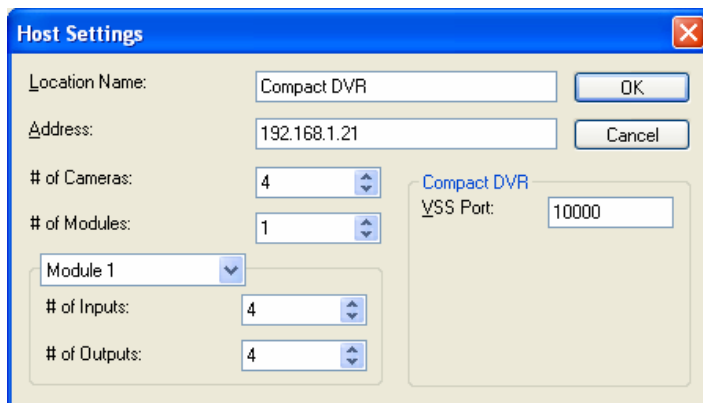

Figure 10-8

6. Give the GV-Compact DVR V3 a location name, and type its IP address (or domain name). Keep the default VSS port as **10000**, or modify it to match that of GV-Compact DVR V3.
7. Click **OK** to save the settings.
8. Expand the created host folder. Drag and drop the icons of cameras and I/O devices onto the imported E-Map.
9. Close the E-Map Editor. Click **Yes** when you are promoted to save the file.

For details on creating an E-Map file on the E-Map Server, see “E-Map Server”, *Chapter 9 E-Map Application, DVR User’s Manual* on the Surveillance System Software CD/DVD.

### Connecting to GV-Compact DVR V3

Depending on where you save the created E-Map file (GV-System, E-Map Server or Control Center), the steps to open the Remote E-Map window for monitoring may vary slightly. The following is the connection example when you store the E-Map file in the GV-System.

1. To enable the remote access to the GV-System, click the **Network** button, select **WebCam Server** to display the Server Setup dialog box, and click **OK** to start the WebCam server.
2. At the local computer, open the Web browser and type the address of the GV-System. The Single View page appears.
3. Select **Emap**. The valid user name and password are required for login. For the first-time user, you will be directed to the Download page. Install the E-Map program before you can run it.
4. On the Remote E-Map window, click the **Login** button and select the GV-Compact DVR V3 host to access its videos and I/O devices. The valid user name and password are required to log in the GV-Compact DVR V3.

For details on the Remote E-Map functions, see “The Remote E-Map Window”, *Chapter 9 E-Map Application, DVR User’s Manual* on the Surveillance System Software CD/DVD.

# Chapter 11 CMS Configurations

This section introduces the related settings to enable connecting to the GV-Compact DVR V3 in the central monitoring stations Center V2, VSM, Dispatch Server and Control Center.

## 11.1 Center V2

The Center V2 can monitor and manage the cameras and I/O devices connected to the GV-Compact DVR V3. The following illustration takes the eight-channel GV-Compact DVR V3 as the example.

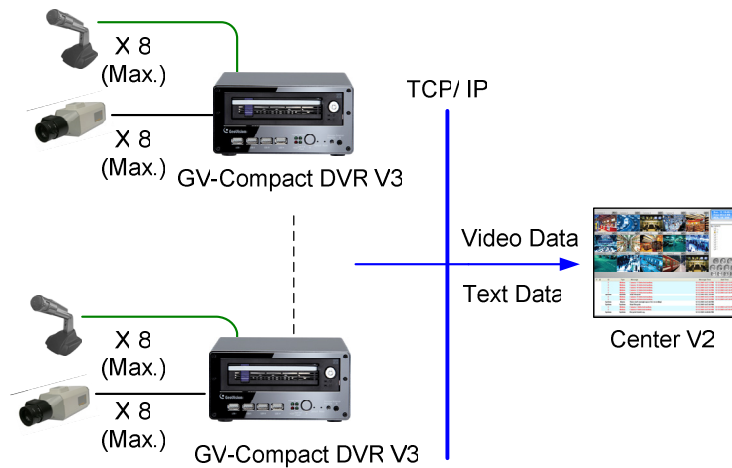

Figure 11-1

- To set the appropriate port connecting to the GV-Compact DVR V3, click the **Preference Settings** button, select **System Configure**, click the **Network** tab, and select **Accept connections from GV-Compact DVR, Video Server & IP Cam**. Keep default port **5551**, or modify it to match the Center V2 port on the GV-Compact DVR V3.

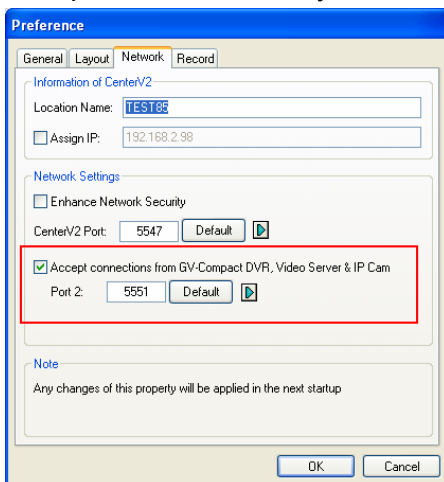

Figure 11-2

- To define how to display the received video on motion detection and input trigger from the GV-Compact DVR V3, click the **Preference Setting** button and select **System Configure**. This dialog box appears.

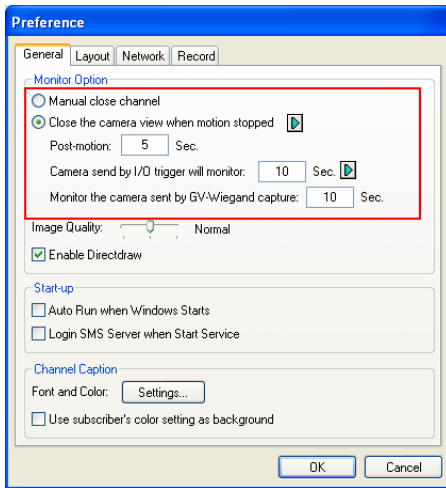

Figure 11-3

- **Manual close channel:** Closes the triggered camera view manually.
- **Close the camera view when motion stopped:** Closes the triggered camera view automatically when motion stops.
- **Post Motion:** Specify the duration of the camera view remaining on the monitoring window after motion stops.
- **Camera send by I/O trigger will monitor:** Specify the duration of the camera view remaining on the monitoring window when an I/O device is triggered.

To keep the camera view remaining on the monitoring window even after the alarm is finished, click the right-arrow button, and uncheck **Latch Trigger**. Then the camera view will keep remaining on the monitoring window for the specified time. For example, the alarm is triggered for 5 minutes and you set 10 minutes, which means the total display time will be 15 minutes.

For details on how to manage the received video from the GV-Compact DVR V3, see *GV-CMS Series User's manual*.

## 11.2 VSM

The VSM can monitor and manage the cameras and I/O devices connected to the GV-Compact DVR V3. The following illustration takes the eight-channel GV-Compact DVR V3 as the example.

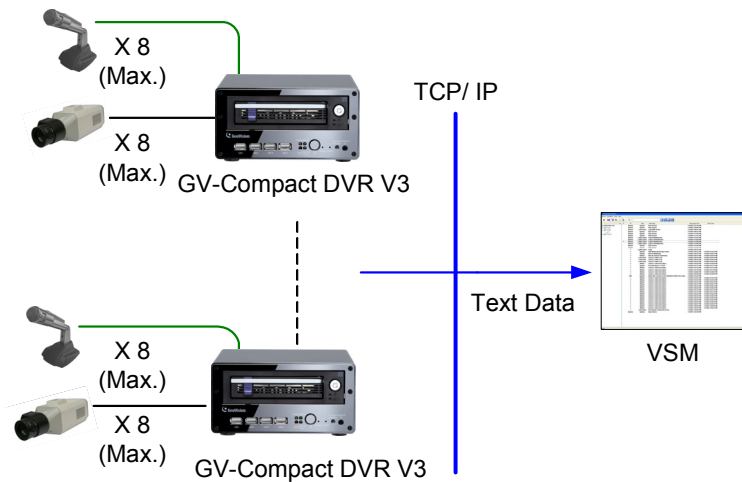

Figure 11-4

- To set the appropriate port connecting to the GV-Compact DVR V3, click **Configure** on the window menu, and select **System Configure** to display this dialog box. Under the Connective Port, keep the default **Port 2** value of **5609**, or modify it to match the VSM port on the GV-Compact DVR V3.

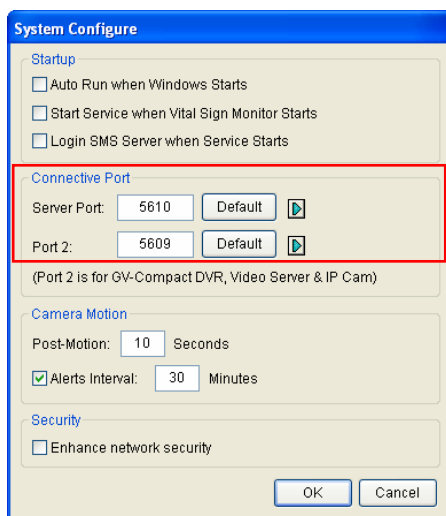

Figure 11-5

For details on how to manage the received video from the GV-Compact DVR V3, see *GV-CMS Series User's manual*.

### 11.3 Dispatch Server

The Dispatch Server can manage the cameras and I/O devices connected to GV-Compact DVR V3, and distribute them to the Center V2. The following illustration takes the eight-channel GV-Compact DVR V3 as the example.

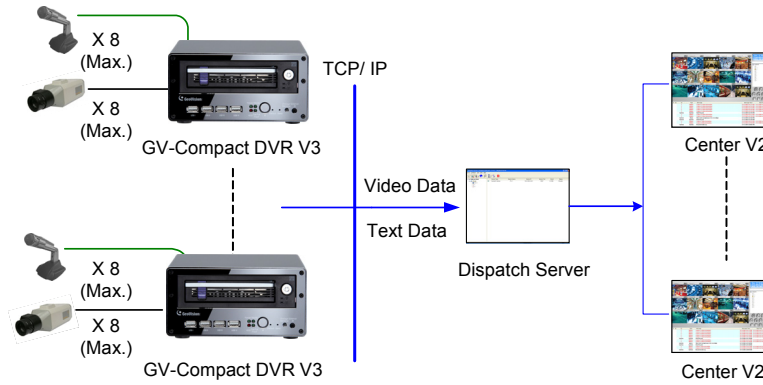

Figure 11-6

- To enable connecting to the GV-Compact DVR V3, click the **Server Setting** button on the toolbar, and enable **Allow Video Server Login as Subscriber from Port**. Keep the default port as **5551**, or modify it to match the Center V2 port on the GV-Compact DVR V3.

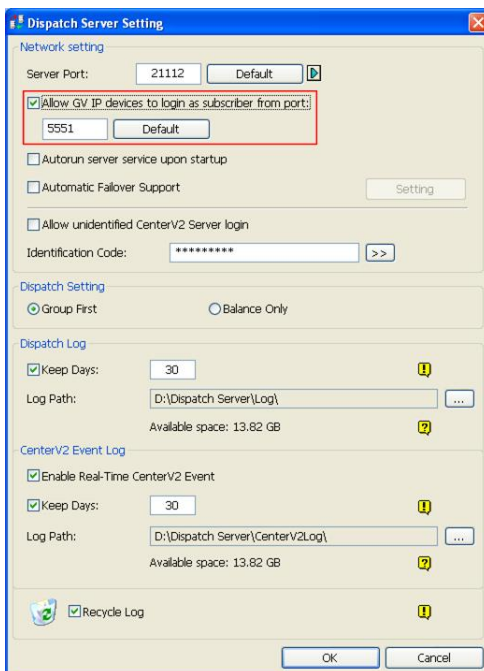

Figure 11-7

For details on how to manage the received video from the GV-Compact DVR V3, see *GV-CMS Series User's manual*.

## 11.4 Control Center

With the Matrix View function, the Control Center can display up to 96 cameras from different hosts on the same screen. The following illustration takes the eight-channel GV-Compact DVR V3 as the example.

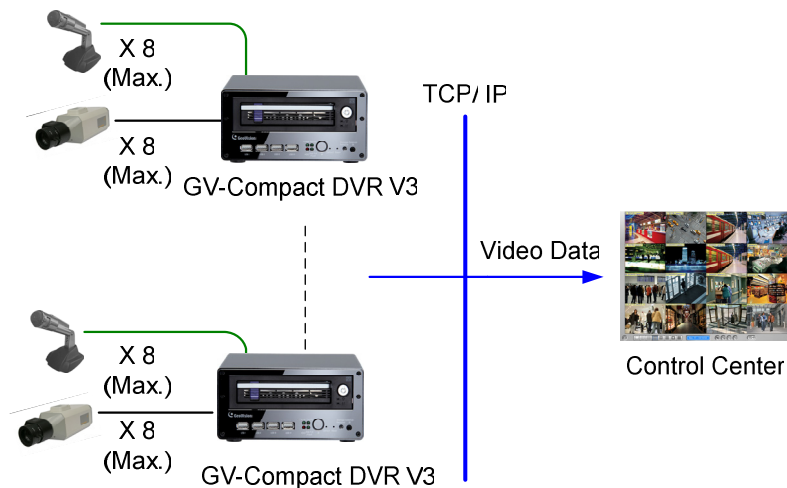

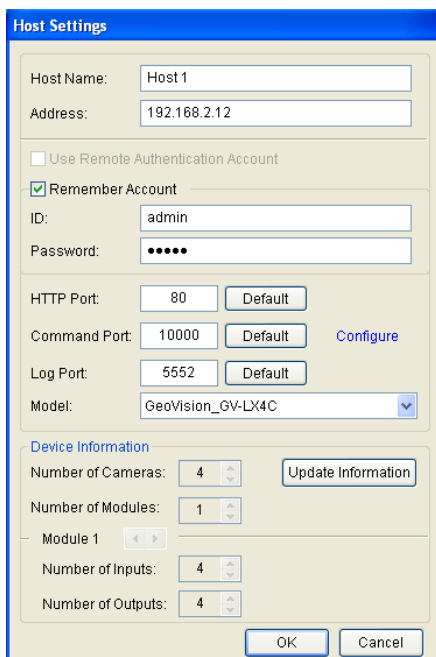

Figure 11-8

- To create a host of the GV-Compact DVR V3, click the **Host List** button  on the toolbar, right-click the Host List window and select **Add Compact DVR**. This dialog box appears. Type the host name, IP address, login ID and password of the host. Keep the communication port as default, unless otherwise necessary.



The screenshot shows the 'Host Settings' dialog box with the following fields and options:

- Host Name: Host 1
- Address: 192.168.2.12
- Use Remote Authentication Account
- Remember Account
- ID: admin
- Password: [masked]
- HTTP Port: 80 (Default)
- Command Port: 10000 (Default) [Configure]
- Log Port: 5552 (Default)
- Model: GeoVision\_GV-LX4C
- Device Information:
  - Number of Cameras: 4 [Update Information]
  - Number of Modules: 1
  - Module 1:
    - Number of Inputs: 4
    - Number of Outputs: 4
- Buttons: OK, Cancel

Figure 11-9

- To run Matrix View, highlight a Group at the Control Center, and click the **Matrix** button  .

For details on how to manage the received video from the GV-Compact DVR V3, see *GV-CMS Series User's manual*.



# Chapter 12 The I/O Terminal Block

The I/O terminal block, located on the rear panel, can be used to develop applications for alarm input and output, motion detection, PTZ control, GPS tracking or a variety of other functions.

## 12.1 Pin Assignment

### 12.1.1 The Four-Channel Unit

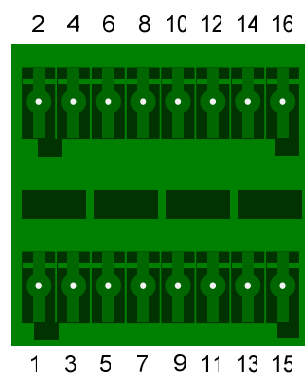

Figure 12-1

Pin	Function	Pin	Function
1	Relay Output 1	9	Relay COM
2	Digital Input 1	10	Ground
3	Relay Output 2	11	DC 12V Out for camera power supply
4	Digital Input 2	12	(reserved)
5	Relay Output 3	13	RS-485 + for PTZ control
6	Digital Input 3	14	Standard (reserved)
			Anti-Vibration ACC 12V_Standby
7	Relay Output 4	15	RS-485 – for PTZ control
8	Digital Input 4	16	Standard (reserved)
			Anti-Vibration ACC ACC wire connection

**Note:** Currently the standard models (GV-LX4C3D1 / GV- LX4C3D2 / GV- LX4C3D2W / GV-LX8CD1 / GV-LX8CD2 / GV-LX8CD2W) do not support GPS receiver and GPS function.

12.1.2 The Eight-Channel Unit

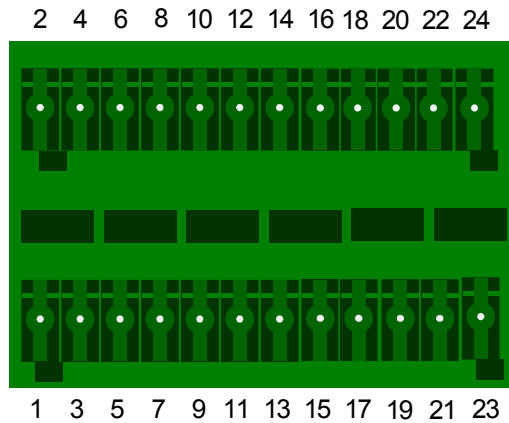

Figure 12-2

Pin	Function	Pin	Function	
1	Digital Output 1	13	Digital Output 7	
2	Digital Input 1	14	Digital Input 7	
3	Digital Output 2	15	Digital Output 8	
4	Digital Input 2	16	Digital Input 8	
5	Digital Output 3	17	DC 12V Out for camera power supply	
6	Digital Input 3	18	Ground	
7	Digital Output 4	19	DC 12V Out for camera power supply	
8	Digital Input 4	20	Ground	
9	Digital Output 5	21	RS-485 + for PTZ control	
10	Digital Input 5	22	Standard	(Reserved)
			Anti-Vibration ACC	12V_Standby
11	Digital Output 6	23	RS-485 – for PTZ control	
12	Digital Input 6	24	Standard	(Reserved)
			Anti-Vibration ACC	ACC wire connection

**Note:** Currently the standard models (GV-LX4C3D1 / GV- LX4C3D2 / GV- LX4C3D2W / GV-LX8CD1 / GV-LX8CD2 / GV-LX8CD2W) do not support GPS receiver and GPS function.

## 12.2 Output Devices

### 12.2.1 The Four-Channel Unit

The relay outputs on the terminal block can only drive a maximum load of 0.3A 125V AC or 1A 30V DC. Working in conjunction with the GV-Relay V2, which is an optional product, the GV-Compact DVR V3 can drive heavier loads.

GV-Compact DVR V3	Without GV-Relay V2	With GV-Relay V2
<b>Maximum load of voltage</b>	0.3A 125V AC, 1A 30V DC	10A 250V AC, 10A 125V AC, 5A 100V DC

To connect the GV-Relay V2 to the GV-Compact DVR V3, refer to the figure and table below.

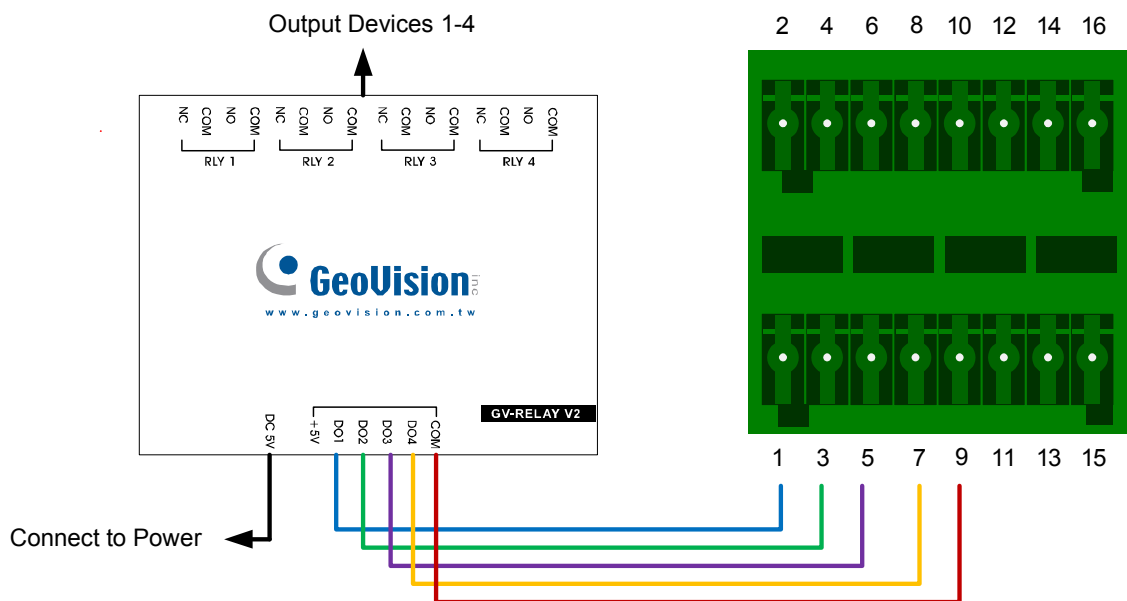

Figure 12-3

GV-Relay V2	Terminal Block
DO 1	Pin 1
DO 2	Pin 3
DO 3	Pin 5
DO 4	Pin 7
COM	Pin 9

### 12.2.2 The Eight-Channel Unit

The digital outputs on the terminal block can only drive a maximum load of 0.15A DC. Working in conjunction with the GV-Relay V2, which is an optional product, the GV-Compact DVR V3 can drive heavier loads.

<b>GV-Compact DVR V3</b>	<b>Without GV-Relay V2</b>	<b>With GV-Relay V2</b>
<b>Maximum load of voltage</b>	0.15A DC	10A 250V AC, 10A 125V AC, 5A 100V DC

The eight-channel GV-Compact DVR V3 can connect to up to two GV-Relay V2 modules. To connect the GV-Relay V2 modules to the GV-Compact DVR V3, refer to the figure and table below.

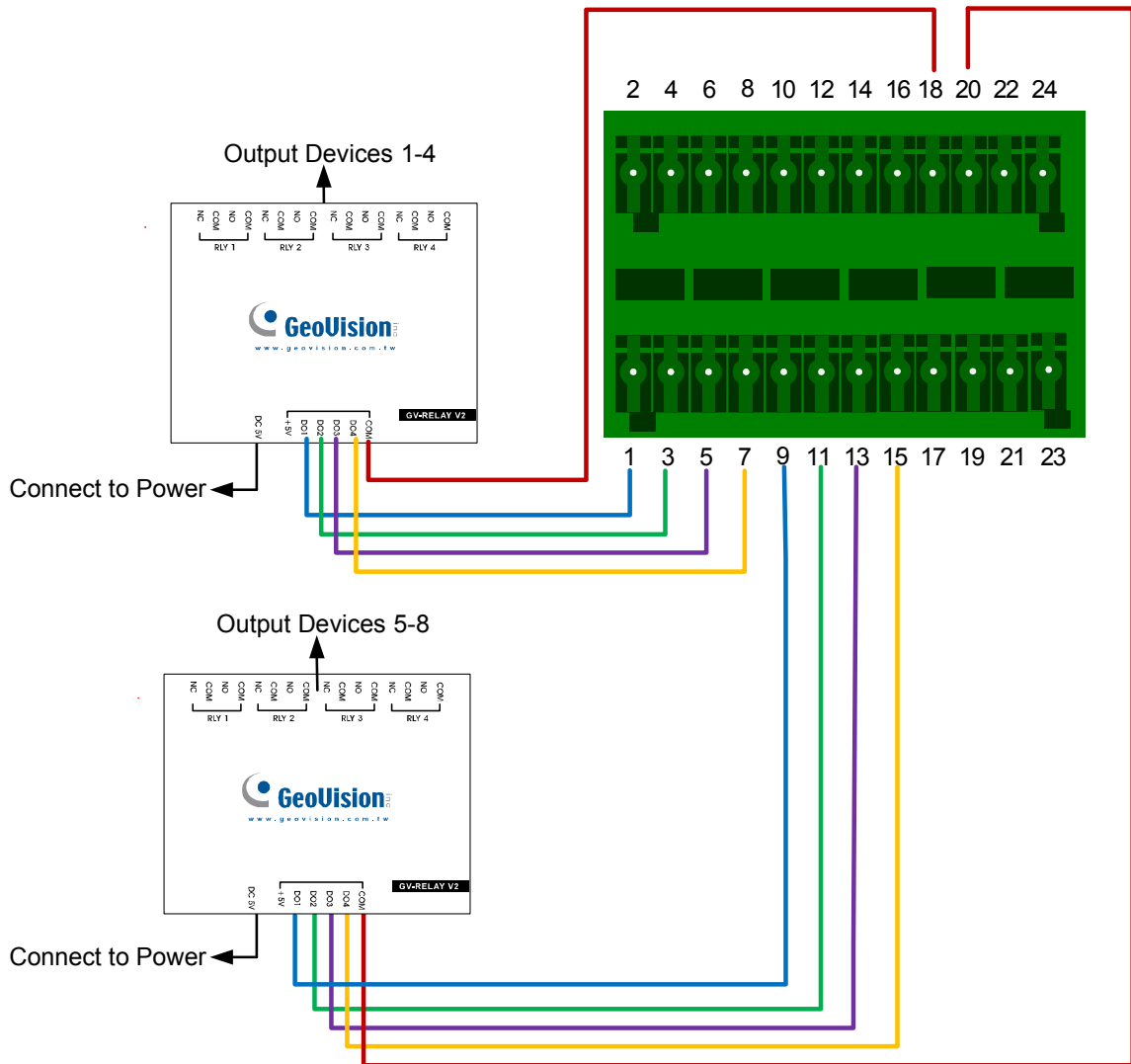

Figure 12-4

GV-Relay V2 with 1 to 4 output devices	Terminal Block	GV-Relay V2 with 5 to 8 output devices	Terminal Block
DO 1	Pin 1	DO 1	Pin 9
DO 2	Pin 3	DO 2	Pin 11
DO 3	Pin 5	DO 3	Pin 13
DO 4	Pin 7	DO 4	Pin 15
COM	Pin 18	COM	Pin 20

## 12.3 Camera Power Supply

### 12.3.1 The Four-Channel Unit

The cameras can be powered through GV-Compact DVR V3. Using the supplied Camera Power Cable, connect the black wire to Pin 10 and the red wire to Pin 11.

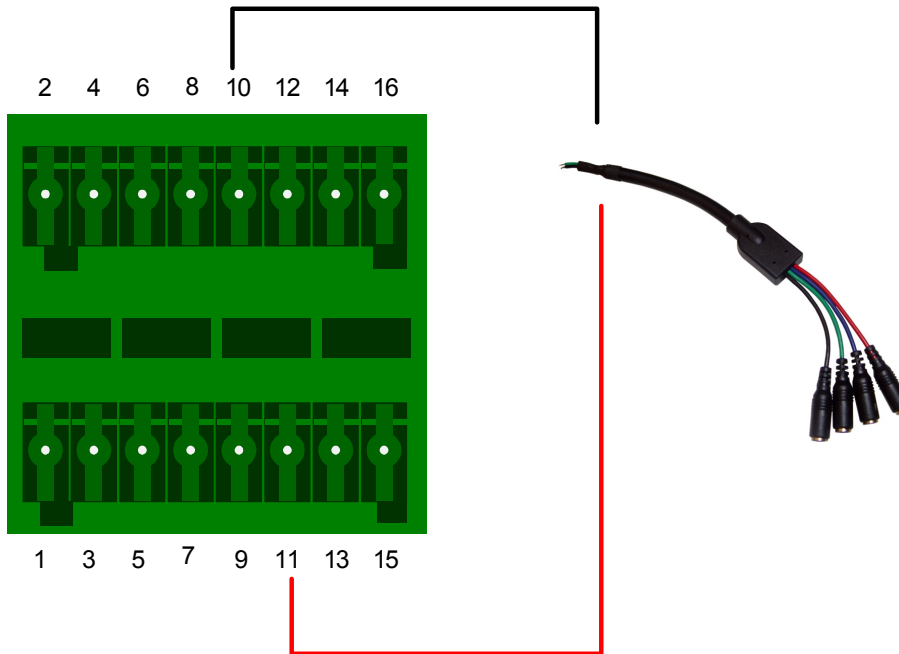

Figure 12-5

Terminal Block	Camera Power Cable
Pin 10	Black Wire
Pin 11	Red Wire

### 12.3.2 The Eight-Channel Unit

The cameras can be powered through GV-Compact DVR V3. Using the two supplied Camera Power Cables, connect the black wire to any of Pin 18 and Pin 20, and the red wire any of Pin 17 and Pin 19.

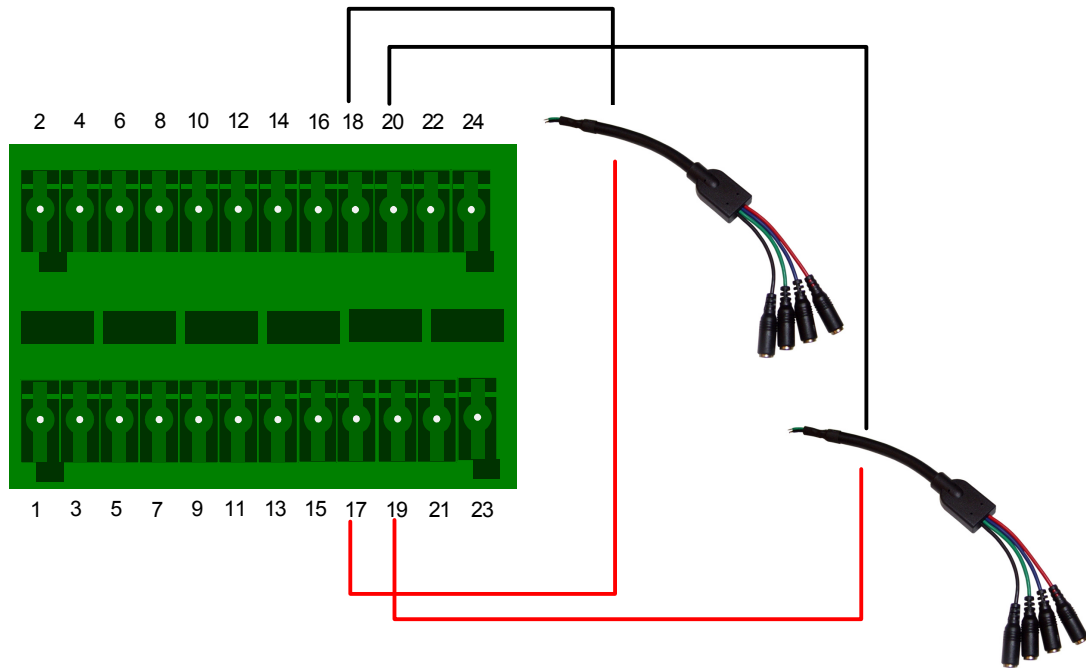

Figure 12-6

Terminal Block	Camera Power Cable
Pin 17	Red Wire
Pin 18	Black Wire
Pin 19	Red Wire
Pin 20	Black Wire

## Specifications: The Four-Channel Unit

### Video

Model		GV-LX4C3D1	GV-LX4C3D2	GV-LX4C3D2W	GV-LX4C3V (ACC Model)
Video Standard		NTSC, PAL			
Video Input/Output		4 Videos In, 4 Loops Out			
Compression		H.264			
Frame Rate		30 fps/ch at resolution of 704 x 480 (NTSC)			
		25 fps/ch at resolution of 704 x 576 (PAL)			
Video Resolution	NTSC	704 x 480, 704 x 480 De-interlace, 352 x 240			
	PAL	704 x 576, 704 x 576 De-interlace, 352 x 288			
Video Streaming		Configurable frame rate and bandwidth			
Video Adjustment		Brightness, Contrast, Hue, Saturation			

### Audio

Model		GV-LX4C3D1	GV-LX4C3D2	GV-LX4C3D2W	GV-LX4C3V (ACC Model)
Audio Input/Output		4 Audios In, 1 Audio Out			
Compression		G.723			

### Output Signal Formats

Model		GV-LX4C3D1	GV-LX4C3D2	GV-LX4C3D2W	GV-LX4C3V (ACC Model)
Resolution	VGA Out	800 x 600, 1024 x 768, 1280 x 1024			
	TV Out	640 x 480			
V. Frequency	VGA Out	60 Hz			
	TV Out	60 Hz			



## Management

Model		GV-LX4C3D1	GV-LX4C3D2	GV-LX4C3D2W	GV-LX4C3V (ACC Model)
Event Management	Trigger	Time, Sensor Input Triggered, Motion Detected			
	Action	<ul style="list-style-type: none"> <li>• Store video to HDD (AVI format)</li> <li>• Send e-mails with captured images</li> <li>• Upload captured images to FTP Server</li> <li>• Monitor through Center V2, VSM and GV-GIS</li> <li>• Activate relay outputs to control external devices</li> </ul>			
Firmware Upgrade		<ul style="list-style-type: none"> <li>• Remote upgrade by Web browser</li> <li>• Use a USB flash drive</li> <li>• Use the upgrade utility included on the Software CD/DVD</li> </ul>			
Client PC Requirements		Microsoft Internet Explorer 7.x or above running on Windows XP / Vista / 7 / 8 / Server 2008 / Server 2012			
Language on Web Interface		Bulgarian / Czech / Danish / Dutch / English / French / German / Greek / Hebrew / Hindi / Hungarian / Italian / Indonesian / Japanese / Norwegian / Lithuanian / Persian / Polish / Portuguese / Romanian / Russian / Serbian / Simplified Chinese / Slovakian / Slovenian / Spanish / Thai / Traditional Chinese / Turkish			
Language on OSD		Czech / Danish / English / French / German / Hebrew / Hungarian / Italian / Japanese / Polish / Portuguese / Russian / Serbian / Simplified Chinese / Spanish / Traditional Chinese			
<p><b>Note:</b> Internet Explorer 10 is not supported in all the firmware of GV-Compact DVR V3.</p>					

## Network

Model	GV-LX4C3D1	GV-LX4C3D2	GV-LX4C3D2W	GV-LX4C3V (ACC Model)
Interface	<ul style="list-style-type: none"> <li>• 10/100 Base-T Ethernet</li> <li>• 802.11b/g/n Wireless LAN (optional)</li> <li>• Mobile broadband: UMTS, EDGE, etc. (optional)</li> </ul>			
Protocol	HTTP, HTTPS, TCP, UDP, SMTP, FTP, DHCP, NTP, UPnP, DynDNS, Multicast, 3GPP/ISMA, RTSP, SNMP, QoS (DSCP)			
Security	IP address filtering			

## Specifications: The Four-Channel Unit

### External Interface

Model	GV-LX4C3D1	GV-LX4C3D2	GV-LX4C3D2W	GV-LX4C3V (ACC Model)
Audio/Video Input	D-Type, DB 15 connector (4 Videos In, 4 Audios In)			
Audio/Video Output	D-Type, DB 15 connector (1 TV Out, 1 Spot Out, 1 VGA Out, 1 Audio Out, 4 Video Loops Out)			
Sensor Input	4 inputs on terminal block			
Alarm Output	4 outputs on terminal block			
PTZ	RS-485 +/- outputs on terminal block			
ACC Wire Connection	None			
GPS	None			
Ethernet	RJ-45, 10/100 Mbps			
USB	2 ports (USB 2.0)			
IR Receiver	1 port for optional External IR Receiver			
Power	12V, 5A (60 W Max.)			

### Alarm

Model	GV-LX4C3D1	GV-LX4C3D2	GV-LX4C3D2W	GV-LX4C3V (ACC Model)
Sensor Input	4 digital inputs			
Alarm Output	4 relay outputs			

### Environment

Model	GV-LX4C3D1	GV-LX4C3D2	GV-LX4C3D2W	GV-LX4C3V (ACC Model)
Operation Temp.	-20 ~ 50 °C (4 ~ 122 °F)			
Humidity	5 ~ 85% RH (non-condensing)			

### Reliability (for GV-LX4C3V only)

Operating Shock	10G, 2 ms
Operating Vibration	5 ~ 500 Hz, 1G

## Physical

Model	GV-LX4C3D1	GV-LX4C3D2	GV-LX4C3D2W	GV-LX4C3V (ACC Model)
<b>Dimensions (L x W x H)</b>	244 x 176 x 86 mm (9.6 x 6.93 x 3.39 in)	244 x 176 x 130 mm (9.6 x 6.93 x 5.12 in)	244 x 176 x 130 mm (9.6 x 6.93 x 5.12 in)	
<b>Weight</b>	2.3 Kg (5 lb)	3.2 Kg (7 lb)	3.3 Kg (7.3 lb)	
<b>HDD Drive Bay</b>	1 bay	2 bays	1 bay	
<b>DVD-RW Drive</b>	None			1 drive

## Optional Storage

Model	GV-LX4C3D1	GV-LX4C3D2	GV-LX4C3D2W	GV-LX4C3V (ACC Model)
<b>SATA HDD of 2.5" or 3.5"</b>	1 SATA HDD	2 SATA HDD	1 SATA HDD	
<b>USB HDDs</b>	2 external USB HDDs			
<b>DVD-RW Backup</b>	DVD-RW backup	DVD-RW backup	N/A (already equipped)	

**Note:**

1. SATA II/III HDD and SSD are supported, but some SATA III HDD and SSD may have compatibility issues with the device.
2. For the Anti-vibration ACC models (GV-LX4C3V, GV-LX8CV1 and GV-LX8CV2), it is necessary to use the hard drive especially for notebook, vehicle or surveillance applications, and tightly fasten the unit on the vehicle to prevent vibration and shock hazard.
3. Currently 3 TB HDD is not supported.
4. For 2.5" HDD, the HDD converter is required from GeoVision.
5. The CD-R and CD-RW backup are not supported.

## Regulatory

<b>Regulatory</b>	CE, FCC, C-Tick, RoHS compliant
-------------------	---------------------------------

All specifications are subject to change without notice.

## Specifications: The Eight-Channel Unit

### Video

Model	GV-LX8CD1	GV-LX8CD2	GV-LX8CD2W	GV-LX8CV1 (ACC Model)	GV-LX8CV2 (ACC Model)
Video Standard	NTSC, PAL				
Video Input/Output	8 Videos In, 8 Loops Out				
Compression	H.264				
Frame Rate	15 fps/ch at resolution of 704 x 480 (NTSC)				
	12.5 fps/ch at resolution of 704 x 576 (PAL)				
Video Resolution	NTSC	704 x 480, 704 x 480 De-interlace, 352 x 240			
	PAL	704 x 576, 704 x 576 De-interlace, 352 x 288			
Video Streaming	Configurable frame rate and bandwidth				
Video Adjustment	Brightness, Contrast, Hue, Saturation				
<b>Note:</b> When the resolution is set at 704 x 480 / 704 x 576, the frame rate for recording and live view will be 15 fps/ch (NTSC) or 12.5 fps/ch (PAL).					

### Audio

Model	GV-LX8CD1	GV-LX8CD2	GV-LX8CD2W	GV-LX8CV1 (ACC Model)	GV-LX8CV2 (ACC Model)
Audio Input/Output	8 Audios In, 1 Audio Out				
Compression	G.723				

### Output Signal Formats

Model	GV-LX8CD1	GV-LX8CD2	GV-LX8CD2W	GV-LX8CV1 (ACC Model)	GV-LX8CV2 (ACC Model)
Resolution	VGA Out	800 x 600, 1024 x 768, 1280 x 1024			
	TV Out	640 x 480			
V. Frequency	VGA Out	60 Hz			
	TV Out	60 Hz			

## Management

Model		GV-LX8CD1	GV-LX8CD2	GV-LX8CD2W	GV-LX8CV1 (ACC Model)	GV-LX8CV2 (ACC Model)
Event Management	Trigger	Time, Sensor Input Triggered, Motion Detected				
	Action	<ul style="list-style-type: none"> <li>• Store video to HDD (AVI format)</li> <li>• Send e-mails with captured images</li> <li>• Upload captured images to FTP Server</li> <li>• Monitor through Center V2, VSM and GV-GIS</li> <li>• Activate relay outputs to control external devices</li> </ul>				
Firmware Upgrade		<ul style="list-style-type: none"> <li>• Remote upgrade by Web browser</li> <li>• Use a USB flash drive</li> <li>• Use the upgrade utility included on the Software CD/DVD</li> </ul>				
Client PC Requirements		Microsoft Internet Explorer 7.x or above running on Windows XP / Vista / 7 / 8 / Server 2008 / Server 2012				
Language on Web Interface		Bulgarian / Czech / Danish / Dutch / English / French / German / Greek / Hebrew / Hindi / Hungarian / Italian / Indonesian / Japanese / Norwegian / Lithuanian / Persian / Polish / Portuguese / Romanian / Russian / Serbian / Simplified Chinese / Slovakian / Slovenian / Spanish / Thai / Traditional Chinese / Turkish				
Language on OSD		Czech / Danish / English / French / German / Hebrew / Hungarian / Italian / Japanese / Polish / Portuguese / Russian / Serbian / Simplified Chinese / Spanish / Traditional Chinese				
<p><b>Note:</b> Internet Explorer 10 is not supported in all the firmware of GV-Compact DVR V3.</p>						

## Optional Storage

Model	GV-LX8CD1	GV-LX8CD2	GV-LX8CD2W	GV-LX8CV1 (ACC Model)	GV-LX8CV2 (ACC Model)
SATA HDD of 2.5" or 3.5"	1 SATA HDD	2 SATA HDD	1 SATA HDD	1 SATA HDD	2 SATA HDD
USB HDDs	4 external USB HDDs				
DVD-RW Backup	DVD-RW backup	DVD-RW backup	N/A (already equipped)	DVD-RW backup	DVD-RW backup

### Note:

1. SATA II/III HDD and SSD are supported, but some SATA III HDD and SSD may have compatibility issues with the device.
2. For the Anti-vibration ACC models (GV-LX4C3V, GV-LX8CV1 and GV-LX8CV2), it is necessary to use the hard drive especially for notebook, vehicle or surveillance applications, and tightly fasten the unit on the vehicle to prevent vibration and shock hazard.
3. Currently 3 TB HDD is not supported.
4. For 2.5" HDD, the HDD converter is required from GeoVision.
5. The CD-R and CD-RW backup are not supported.

## Specifications: The Eight-Channel Unit

### Network

Model	GV-LX8CD1	GV-LX8CD2	GV-LX8CD2W	GV-LX8CV1 (ACC Model)	GV-LX8CV2 (ACC Model)
Interface	<ul style="list-style-type: none"> <li>• 10/100/1000 Base-T Ethernet</li> <li>• 802.11b/g/n Wireless LAN (optional)</li> <li>• Mobile broadband: UMTS, EDGE, etc. (optional)</li> </ul>				
Protocol	HTTP, HTTPS, TCP, UDP, SMTP, FTP, DHCP, NTP, UPnP, DynDNS, 3GPP/ISMA, RTSP, SNMP, QoS (DSCP)				
Security	IP address filtering				

### External Interface

Model	GV-LX8CD1	GV-LX8CD2	GV-LX8CD2W	GV-LX8CV1 (ACC Model)	GV-LX8CV2 (ACC Model)
Audio/Video Input	D-Type, DB 15 connector (8 Videos In, 8 Audios In)				
Audio/Video Output	D-Type, DB 15 connector (1 TV Out, 1 Spot Out, 1 VGA Out, 1 Audio Out, 8 Video Loops Out)				
Sensor Input	8 inputs on terminal block				
Alarm Output	8 outputs on terminal block				
PTZ	RS-485 +/- outputs on terminal block				
ACC Wire Connection	None			1 output on terminal block	
GPS	None			1 port (PS/2 connector)	
Ethernet	RJ-45, 10/100/1000 Mbps				
USB	4 ports (USB 2.0)				
IR Receiver	1 port for optional External IR Receiver				
Power	12V, 5A (60 W Max.)			10 ~ 28V, 5A (60 W Max.)	

### Alarm

Model	GV-LX8CD1	GV-LX8CD2	GV-LX8CD2W	GV-LX8CV1 (ACC Model)	GV-LX8CV2 (ACC Model)
Sensor Input	8 digital inputs				
Alarm Output	8 digital outputs				

## Environment

Model	GV-LX8CD1	GV-LX8CD2	GV-LX8CD2W	GV-LX8CV1 (ACC Model)	GV-LX8CV2 (ACC Model)
Operation Temp.	-20 ~ 50 °C (4 ~ 122 °F)				
Humidity	5 ~ 85% RH (non-condensing)				

## Physical

Model	GV-LX8CD1	GV-LX8CD2	GV-LX8CD2W	GV-LX8CV1 (ACC Model)	GV-LX8CV2 (ACC Model)
Dimensions (L x W x H)	244 x 176 x 91 mm (9.6 x 6.93 x 3.58")	244 x 176 x 130 mm (9.6 x 6.93 x 5.12")	244 x 176 x 130 mm (9.6 x 6.93 x 5.12")	244 x 258 x 101 mm (9.6 x 10.16 x 3.98")	244 x 258 x 140 mm (9.6 x 10.16 x 5.51")
Weight	2.3 Kg (5 lb)	3.2 Kg (7 lb)	3.3 Kg (7.3 lb)	2.9 Kg (6.4 lb)	3.8 Kg (8.4 lb)
HDD Drive Bay	1 bay	2 bays	1 bay	1 bay	2 bays
DVD-RW Drive	None		1 drive	None	

## Reliability (for ACC models only)

Operating Shock	10G, 2 ms
Operating Vibration	5 ~ 500 Hz, 1G

## Regulatory

Regulatory	CE, FCC, C-Tick, RoHS compliant
------------	---------------------------------

All specifications are subject to change without notice.

## Appendix

### A. Supported Wireless LAN USB Adaptor

Vendor	Model
D-Link	DWA-140 (H/W version B1), DWL-G122 (version C1)
EDIMAX	EW-7318Ug, EW-7718Un, EW-7711UAn
Linksys	WUSB54GC, WUSB600 (version 1)
Pegatron	WL-166N11
<b>Note:</b> Linksys WUSB54GC ver. 3 is not supported.	

### B. Supported Mobile Broadband Device

Vendor	Model
Bandluxe	C320
HUAWEI	EC169C, EC189, E169, E220, E303, E353, E1692, E1750, E1752 and E1756, E1756C USB Modem (HSDPA/UMTS/EDGE/GPRS/GSM)
Novatel	MC950D and MC996D (HSDPA/UMTS/EDGE/GPRS/GSM)
ONDA	MSA523HS
Verizon	USB760 Modem (EVDO)
Vodafone	K3565 (Rev 2)



## C. Settings for Internet Explorer 8 or later

If you use Internet Explorer 8 or later, it is required to complete the following setting.

1. Set the Security to **Medium-high (default)**.
2. Enable **Allow previously unused ActiveX controls to run without prompt**.
3. Disable **Only allow approved domains to use ActiveX without prompt**.

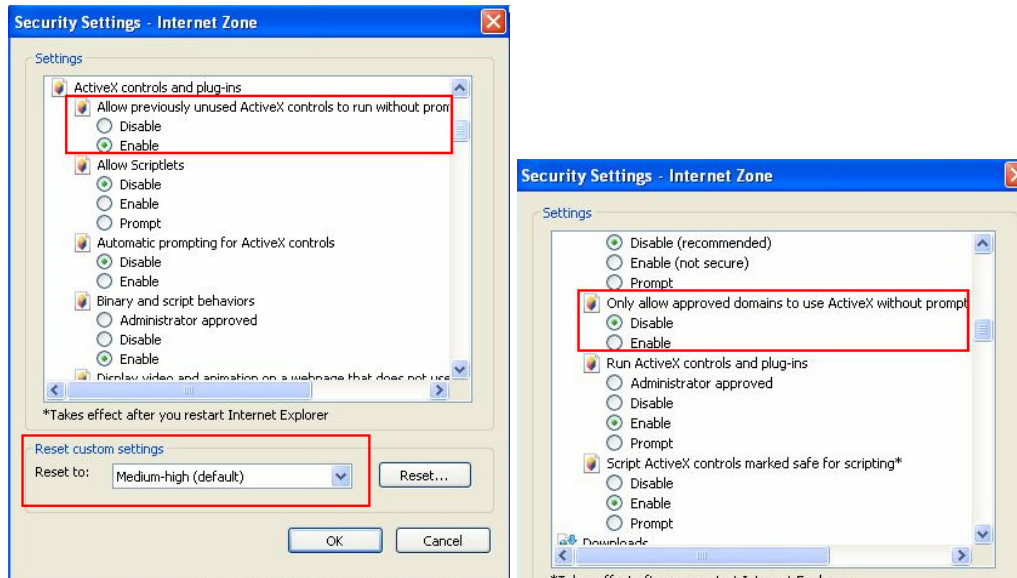

### D. The CGI Command

The GV-Compact DVR V3 supports a CGI command function for obtaining a snapshot of the live view without logging in the Web interface. For a GV-Compact DVR V3 with the following details:

IP address: 192.168.2.109

Username: admin

Password: admin

Desired Stream: 1

Type the following into your Web browser:

<http://192.168.2.109/PictureCatch.cgi?username=admin&password=admin&channel=1>

## E. The RTSP Command

The GV-Compact DVR V3 can support RTSP protocol for both video and audio streaming. For the RTSP command, enter:

```
rtsp://<IP of the GV-Compact DVR V3:8554/<CH No.>.sdp
```

For example, `rtsp://192.168.3.111:8554/CH001.sdp`

---

**Note:**

1. The RTSP server must be enabled on the Web interface. See [6.3.9 RTSP/3GPP](#).
  2. Only VLC and QuickTime players are supported for streaming video via RTSP protocol.
-

## F. Supported PTZ Cameras

The following table shows the supported PTZ cameras listed on the OSD or the Web interface.

Model Name	IE	OSD
360 vision (ViD-18COP04) Pelco P	V	
AcutVista_SSD-7971D	V	V
Ademco (Jupiter)	V	V
Bosch (TC700 / 8560)	V	V
Bosch_G3	V	
Canon (VCC4 / VCC5i)	V	V
CBC (GANZ) (ZC-S120 Series)	V	V
Chiper (CPT-V9KRV)	V	V
COP (15-CD53W) – Pelco D	V	V
COP (15-CD55TW) – Pelco D	V	
COP (15-CD55W) – Pelco D	V	
COP (CD55X) – Pelco D	V	
Direct Perception (PTU Series)	V	V
D-max Dome	V	V
DongYang Dome (DOH-240)	V	V
Dynacolor Dome	V	V
DynaColor (D-7720 / 7722)	V	V
Dynacolor (DynaHawk-ZH701)	V	V
ELBEX (Matrix / 1000)	V	V
ELMO (PTC-1000)	V	
ELMO (PTC-200C)	V	
ELMO (PTC-400C)	V	
EverFocus (EPTZ 1000 / 500)	V	V
Eyeview T-Power (T2-SA27)	V	
GKB (SPD-22I)	V	V
HiSharp – Pelco D	V	V
HiSharp – Pelco P	V	V
JEC Dome	V	V
JVC (TK-S576B / S655 / C686E)	V	V
Kalatel CyberDome	V	V
Kampro Technology (K-ZC23)	V	V

KenKo (DMP23-H1)	V	V
LG (LPT-OS553HQ)	V	V
Lilin (PIH) – MLP1	V	V
Lilin (PIH-7625) – MLP1	V	V
Lilin (PIH-820) – MLP1	V	
MESSOA (D-700 series)	V	V
MESSOA (SDS600 series)	V	V
Minking Dome	V	V
Mintron (54G2AHN / P)	V	
NanWang (NVD 2300PNT)	V	V
NanWangV4.1 (NVD 2300PNT)	V	V
Panasonic (WV-CS850)	V	V
Panasonic (WV-CW960)	V	V
Pelco (Spectra III)	V	V
Pelco Dome	V	V
PelcoSpetra Mini Dome ( SD4-WO)	V	V
Pishion (22X)	V	V
PTZ in I/O	V	V
RX214D	V	
SAE (DR-E588)	V	V
Samsung (SCC-641 / 643)	V	V
Samsung (SPD-1600)	V	V
Samsung (SPD-3300)	V	V
Sensormatic (Ultra IV)	V	V
Sony (EVI-D100)	V	V
StorVision PTZ	V	
TOA (CC551)	V	V
VDI (CT-58SPD)	V	
VIDO.AT Dome	V	V
YAAN (YAAN)	V	V
<b>Total</b>	<b>61</b>	<b>47</b>

**G. Default Port Value**

<b>HTTP Port</b>	80
<b>Video Streaming Port</b>	10000
<b>E-mail Server</b>	25
<b>FTP Server</b>	21
<b>Center V2</b>	5551
<b>VSM</b>	5609
<b>GV-GIS</b>	3356
<b>ViewLog Server</b>	5552
<b>RTSP/TCP Port</b>	8554
<b>RTP/UDP Port</b>	17300-17319