

# GV-AS/EV Controller

## *User's Manual*



Before attempting to connect or operate this product, please read these instructions carefully and save this manual for future use.



© 2014 GeoVision, Inc. All rights reserved.

Under the copyright laws, this manual may not be copied, in whole or in part, without the written consent of GeoVision.

Every effort has been made to ensure that the information in this manual is accurate. GeoVision, Inc. makes no expressed or implied warranty of any kind and assumes no responsibility for errors or omissions. No liability is assumed for incidental or consequential damages arising from the use of the information or products contained herein. Features and specifications are subject to change without notice.

GeoVision, Inc.  
9F, No. 246, Sec. 1, Neihu Rd.,  
Neihu District, Taipei, Taiwan  
Tel: +886-2-8797-8377  
Fax: +886-2-8797-8335  
<http://www.geovision.com.tw>

Trademarks used in this manual: *GeoVision*, the *GeoVision* logo and *GV* series products are trademarks of GeoVision, Inc. *Windows* and *Windows XP* are registered trademarks of Microsoft Corporation.

May 2014

## Contents

<b>Important Notes for Maintaining Power Supply</b> .....	<b>vii</b>
<b>Welcome</b> .....	<b>ix</b>
<b>Elevator Control</b> .....	<b>x</b>
<b>Optional Devices</b> .....	<b>xi</b>
<b>Installation Considerations</b> .....	<b>xiii</b>
<b>Firmware and Software Compatibility</b> .....	<b>xiv</b>
<b>1. GV-AS100 Controller</b> .....	<b>1</b>
1.1 Introduction .....	2
1.1.1 Main Features .....	4
1.1.2 Packing List.....	4
1.1.3 GV-AS100 Board Layout.....	5
1.2 Installation.....	6
1.2.1 Connecting a Wiegand Reader .....	7
1.2.2 Connecting Input Devices .....	7
1.2.3 Connecting Output Devices.....	8
1.2.4 Connecting the PC.....	9
1.2.4.A RS-485 Connection .....	9
1.2.4.B Network Connection .....	10
1.2.4.C Switches.....	10
1.2.5 Connecting the Power .....	11
1.2.6 Fitting the Battery .....	11
1.3 Programming Mode.....	12
1.3.1 Quick Reference of Programming Table .....	14
1.3.2 Accessing the Card Manager .....	15
1.3.2.A Adding a Card.....	15
1.3.2.B Deleting a Card.....	15
1.3.2.C Resetting the APB Function.....	16
1.3.3 Accessing the Security Mode .....	16
1.3.3.A Enabling the Security Mode .....	16
1.3.3.B Disabling the Security Mode .....	16
1.3.4 Setting Parameters .....	17
1.3.5 Displaying System Information.....	19
1.3.6 Restoring Factory Defaults.....	20
1.4 Web-Based Configurations .....	21
1.5 GV-AS100 Specifications.....	22
<b>2. GV-AS110 Controller</b> .....	<b>23</b>

2.1	Introduction .....	24
2.1.1	Main Features .....	26
2.1.2	Packing List.....	26
2.2	Installation.....	27
2.2.1	Connecting a Wiegand Reader .....	28
2.2.2	Connecting Input Devices .....	28
2.2.3	Connecting Output Devices.....	29
2.2.4	Connecting to the PC .....	30
2.2.4.A	RS-485 Connection .....	30
2.2.4.B	Network Connection .....	31
2.2.5	Connecting the Power .....	31
2.3	Programming Mode.....	32
2.3.1	Adding and Deleting Cards .....	32
2.3.1.A	Adding a Card.....	33
2.3.1.B	Deleting a Card.....	33
2.3.2	Programming the GV-AS110.....	34
2.4	LED Status and Beeper .....	37
2.5	Web-Based Configurations .....	39
2.6	GV-AS110 Specifications .....	40
<b>3.</b>	<b>GV-AS120 Controller .....</b>	<b>41</b>
3.1	Introduction .....	42
3.1.1	Main Features .....	44
3.1.2	Packing List.....	44
3.2	Installation.....	45
3.2.1	Connecting a Wiegand Reader .....	46
3.2.2	Connecting Input Devices .....	46
3.2.3	Connecting Output Devices.....	47
3.2.4	Connecting to the PC .....	48
3.2.4.A	RS-485 Connection .....	48
3.2.4.B	Network Connection .....	50
3.2.5	Connecting the Power .....	50
3.3	Programming Mode.....	51
3.3.1	Adding and Deleting Cards .....	51
3.3.1.A	Adding a Card.....	52
3.3.1.B	Deleting a Card.....	52
3.4	LED Status and Beeper .....	53
3.5	Web-Based Configurations .....	54
3.6	GV-AS120 Specifications .....	55

<b>4. GV-AS210 Controller .....</b>	<b>56</b>
4.1 Introduction .....	57
4.1.1 Main Features .....	57
4.1.2 Packing List.....	57
4.2 Installation.....	59
4.2.1 Connecting Card Readers.....	59
4.2.1.A Wiegand Readers.....	59
4.2.1.B RS-485 Readers.....	60
4.2.2 Connecting Input Devices .....	61
4.2.3 Connecting Output Devices.....	62
4.2.4 Connecting Backup Battery.....	63
4.2.5 Connecting the Power.....	63
4.2.6 Connecting the PC.....	64
4.3 Other Settings .....	65
4.3.1 Web Setting Switch.....	65
4.3.2 Resetting the GV-AS210.....	65
4.3.3 Restoring Factory Defaults.....	66
4.4 The Web Interface.....	67
4.5 GV-AS210 Specifications.....	68
<b>5. GV-AS400 Controller .....</b>	<b>69</b>
5.1 Introduction .....	70
5.1.1 Main Features .....	70
5.1.2 Packing List.....	70
5.2 Installation.....	72
5.2.1 Connecting Card Readers.....	72
5.2.1.A Wiegand Readers.....	73
5.2.1.B RS-485 Readers.....	74
5.2.2 Connecting Input Devices .....	75
5.2.3 Connecting Output Devices.....	76
5.2.3.A Outputs 1 ~ 8.....	76
5.2.3.B Outputs 9 ~ 16.....	77
5.2.4 Connecting the Power.....	79
5.2.5 Connecting the PC.....	80
5.2.6 Connecting the External I/O Box .....	81
5.2.7 Fitting the Battery.....	82
5.3 Other Settings .....	83
5.3.1 Web Setting Switch.....	83
5.3.2 Resetting the GV-AS400.....	83

5.3.3 Restoring Factory Defaults.....	84
5.4 The Web Interface.....	85
5.5 Optional GV-ASKeypad .....	86
5.5.1 Installation.....	86
5.5.2 Operation .....	87
5.5.2.A Setting Parameters.....	87
5.5.2.B Displaying System Information .....	88
5.6 GV-AS Power Board .....	89
5.6.1 Main Features .....	89
5.6.2 Connecting Output Devices.....	90
5.6.3 Connecting the Power .....	91
5.6.4 Connecting Backup Battery.....	92
5.7 GV-AS400 Specifications .....	93
<b>6. GV-AS410 / 810 Controller .....</b>	<b>94</b>
6.1 Introduction .....	95
6.1.1 Main Features .....	95
6.1.2 Packing List.....	95
6.2 Installation.....	97
6.2.1 Connecting Card Readers.....	97
6.2.1.A Wiegand Readers.....	97
6.2.1.B RS-485 Readers.....	98
6.2.2 Connecting Input Devices .....	99
6.2.3 Connecting Output Devices.....	100
6.2.4 Connecting Backup Battery.....	101
6.2.5 Connecting the Power .....	101
6.2.6 Connecting the PC.....	102
6.3 Other Settings .....	103
6.3.1 Web Setting Switch .....	103
6.3.2 Resetting the GV-AS410 / 810 .....	103
6.3.3 Restoring Factory Defaults.....	104
6.4 The Web Interface.....	105
6.5 GV-AS410 / 810 Specifications .....	106
<b>7. GV-EV48 Controller .....</b>	<b>107</b>
7.1 Introduction .....	108
7.1.1 Main Features .....	108
7.1.2 Packing List.....	108
7.2 Installation.....	110
7.2.1 Connecting RS-485 Card Readers.....	110

7.2.2	Connecting Output Relay .....	111
7.2.3	Connecting Backup Battery .....	112
7.2.4	Connecting the Power .....	112
7.2.5	Connecting the PC .....	113
7.3	Other Settings .....	114
7.3.1	Web Setting Switch .....	114
7.3.2	Resetting the GV-EV48 .....	114
7.3.3	Restoring Factory Defaults .....	115
7.4	The Web Interface .....	116
7.5	GV-EV48 Specifications .....	117
<b>8.</b>	<b>Installing on a Network .....</b>	<b>118</b>
8.1	Fixed IP Connection .....	120
8.2	DHCP Connection .....	122
8.2.1	Connection over LAN .....	122
8.2.2	Connection over Internet .....	125
<b>9.</b>	<b>The Web Interface .....</b>	<b>128</b>
9.1	Basic Settings .....	130
9.1.1	System Setup .....	130
9.1.2	Upgrading Firmware .....	132
9.1.3	Changing Login ID and Password .....	134
9.2	Advanced Settings .....	135
9.2.1	Function Setting .....	136
9.2.2	Parameter Setting .....	138
9.2.2.A	GV-AS210 / 400 / 410 / 810 .....	138
9.2.2.B	GV-EV48 .....	142
9.2.3	Time Setting .....	144
9.2.4	Input Setting .....	146
9.2.5	Output Setting .....	148
9.2.5.A	Output Function Settings .....	150
9.2.5.B	Output Condition Settings .....	152
9.2.6	Wiegand Function .....	153
9.2.7	Urgent Card .....	154
9.3	Extended Device .....	155
9.3.1	Extended Reader .....	155
9.3.2	Extended I/O .....	158
<b>10.</b>	<b>Optional Devices .....</b>	<b>159</b>
10.1	Optional GV-ASBox .....	160
10.1.1	Main Features .....	160

10.1.2	Packing List.....	160
10.1.3	GV-ASBox Board Layout.....	161
10.1.4	Installation.....	162
10.1.4.A	Connecting GV-AS100 / 110 / 120.....	162
10.1.4.B	Connecting a Wiegand Reader.....	163
10.1.4.C	Connecting GV-Readers and GV-GF Fingerprint Readers.....	164
10.1.4.D	Connecting Input Devices.....	165
10.1.4.E	Connecting Output Devices.....	166
10.1.4.F	Connecting Backup Battery.....	168
10.1.4.G	Other Settings.....	169
10.1.4.G.a	Web Setting Switch.....	169
10.1.4.G.b	Resetting the GV-ASBox.....	169
10.1.4.G.c	Restoring Factory Defaults.....	169
10.1.5	GV-ASBox Specifications.....	170
10.2	Optional GV-ASNet.....	171
10.2.1	Main Features.....	171
10.2.2	Packing List.....	171
10.2.3	GV-ASNet Overview.....	172
10.2.4	Installation.....	173
10.2.4.A	Connecting GV-AS100 / 110 / 120.....	173
10.2.4.B	Connecting GV-Readers and GV-GF Fingerprint Readers.....	174
10.2.4.C	Connecting Backup Battery.....	175
10.2.4.D	Other Settings.....	176
10.2.4.D.a	Web Setting Switch.....	176
10.2.4.D.b	Restoring Factory Defaults.....	176
10.2.4.D.c	Power Status LED.....	176
10.2.5	GV-ASNet Specifications.....	177
10.3	Web Interface through Optional Devices.....	178
10.3.1	Basic Setting.....	178
10.3.2	Advanced Settings.....	179
10.3.2.A	Function Setting.....	180
10.3.2.B	Parameter Setting.....	183
10.3.2.C	Status Monitor.....	187
10.3.2.D	Card Information.....	188
10.3.2.E	Time Setting.....	189
10.3.2.F	In/Out Function.....	190
10.3.2.G	Extended Reader.....	197
<b>11.</b>	<b>Troubleshooting.....</b>	<b>199</b>



# Important Notes for Maintaining Power Supply

To make sure GV-AS / EV Controllers can function properly during a power outage, be sure to replace the internal battery on the controllers when needed. For GV-AS210 / 400 / 410 / 810, it is also recommended to install a backup battery.

Refer to the following sections for instructions on how to install a backup battery:

- GV-AS210: See 4.2.4 *Connecting Backup Battery*
- GV-AS400: See 5.6.4 *Connecting Backup Battery*
- GV-AS410 / 810: See 6.2.4 *Connecting Backup Battery*

## Replacing the Internal Battery

The table below lists the types of internal batteries used by different GV-AS / EV Controllers.

Type of Battery Used	GV-AS / EV Controllers
Mercury Battery	GV-AS100 / AS400
Lithium Battery	GV-AS110 / AS120 / AS210 / AS410 / AS810 / EV48

### Mercury Battery (GV-AS100 / AS400)

For GV-AS100 / AS400, you can replace the battery on your own when you see low battery messages and icons in GV-ASManager.

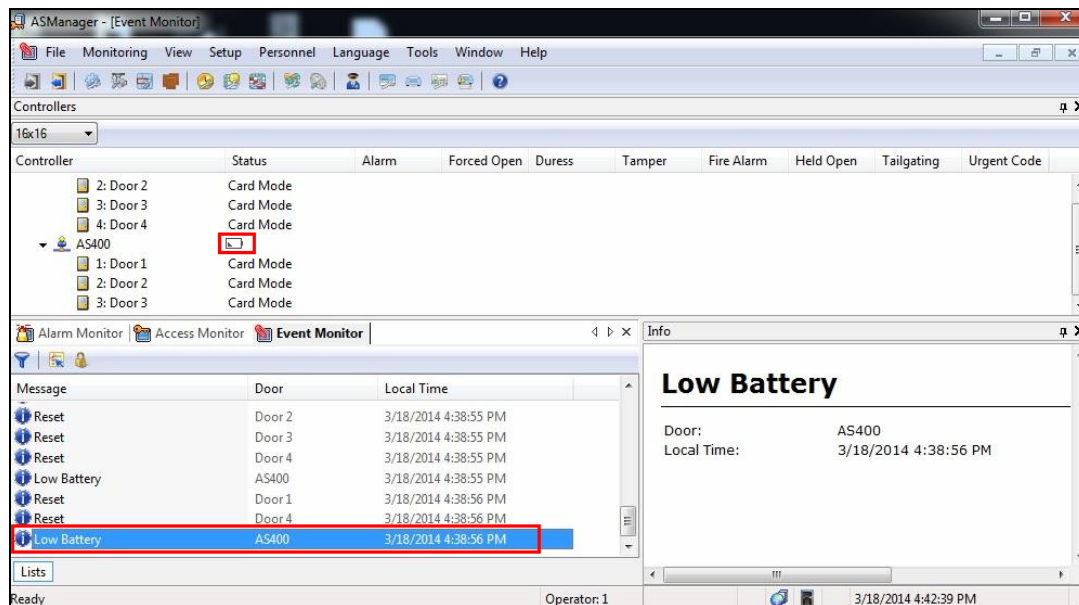

**Note:** Make sure the plastic insulation film under the battery is removed when using GV-AS100 / 400 for the first time. The low battery messages and icons will appear if the plastic film is not removed.

### Lithium Battery (GV-AS110 / AS120 / AS210 / AS410 / AS810 / EV48)

When the controller runs out of battery, the local time on the controller will be reverted back to 1999/12/31. The controller time can be found on the Web interface of the controller on the Time Setting page and in the Access Monitor / Alarm Monitor / Event Monitor of GV-ASManager.

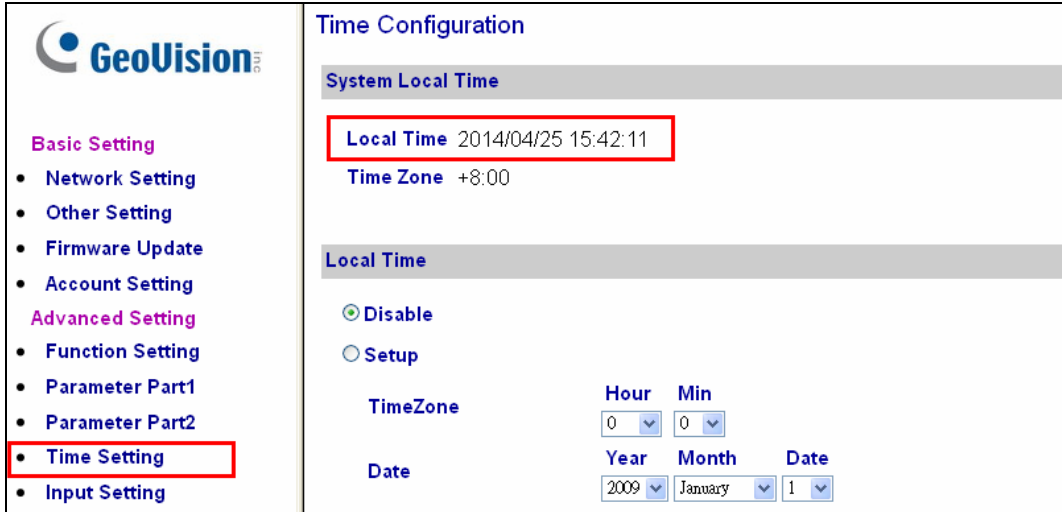

**Time Configuration**

**System Local Time**

**Local Time** 2014/04/25 15:42:11

**Time Zone** +8:00

**Local Time**

Disable

Setup

**TimeZone**

Hour: 0 Min: 0

**Date**

Year: 2009 Month: January Date: 1

When you see the controller year shown as 1999 or 2000, disconnect the controller from power and reconnect it to power. If the year is still shown as 1999 or 2000, the controller battery needs to be replaced. When this occurs, please contact your sales representative and send the controller back to GeoVision for battery replacement.

# Welcome

This user manual includes the following types of GV-AS / GV-EV Controllers:

## GV-AS Controllers

	Doors Supported		Page Number
	One-Way Control	Two-Way Control	
<b>GV-AS100</b>	1	1	See p. 1
<b>GV-AS110</b>	1	1	See p. 23
<b>GV-AS120</b>	1	1	See p. 41
<b>GV-AS210</b>	4	2 (Wiegand) 4 (Wiegand + RS-485 / Network)	See p. 56
<b>GV-AS400</b>	4	4	See p. 69
<b>GV-AS410</b>	4	4	See p. 94
<b>GV-AS810</b>	8	4 (Wiegand), 8 (Wiegand + RS-485 / Network)	See p. 94

## GV-EV Controllers

	Floors Supported	Readers Supported	Page Number
<b>GV-EV48-24 Floors</b>	24	2 (RS-485 or Network)	See p.107
<b>GV-EV48-48 Floors</b>	48		

## Elevator Control

GV-AS / GV-EV Controllers provide two types of elevator control.

For **GV-AS100 / 110 / 120 / 210 / 400 / 410 / 810**, the GV-AS Controller can control access to the elevator call buttons. Users who present the correct identification card to the elevator reader will be able to use the elevator and can go any floors. The output relays are connected to the call button of the elevator.

For **GV-EV48**, a controller especially designed for elevator control, access can be granted to specific floors. You can configure each identification card to specify the floors it can access. In this type of elevator control, each output relay is connected to the button of corresponding floor in the elevator control panel.

## Optional Devices

Optional devices can expand the capabilities and versatilities of your GV-AS / GV-EV Controllers. Consult your sales representative for more information.

<b>GV-ASKeypad</b>	GV-ASKeypad with LCD display is a hot-swapping device, giving you convenience to configure GV-AS400.
<b>GV-Reader 1251</b>	GV-Reader 1251 is a card reader that uses a 125 kHz frequency. It has both Wiegand and RS-485 outputs that can be connected to any standard access control panel.
<b>GV-Reader 1352 V2</b>	GV-Reader 1352 V2 is a card reader that uses a 13.56 MHz frequency. It has both Wiegand and RS-485 outputs that can be connected to any standard access control panel.
<b>GV-RK1352</b>	GV-RK1352 is a card reader with keypad that uses a 13.56 MHz frequency. The reader has both Wiegand and RS-485 outputs that can be connected to any standard access control panel.
<b>GV-R1352</b>	GV-R1352 is a card reader that uses a 13.56 MHz frequency. The reader has both Wiegand and RS-485 outputs that can be connected to any standard access control panel.
<b>GV-GF Fingerprint Reader</b>	The reader supports three operation modes: Fingerprint Only, Fingerprint + Card and Card Only. In Fingerprint Only mode, the fingerprints are enrolled through GV-ASManager. In Fingerprint + Card mode, the fingerprint templates are stored on the user card. In Card Only mode, the users only need to swipe the card to be granted access. Readers with optical and capacitance sensors are available.
<b>GV-CR420</b>	GV-CR420 is a card reader with a built-in 4MP wide angle IP camera. The card reader recognizes identification cards and transmits live view through network connection.
<b>GV-DFR1352</b>	The GV-DFR1352 is a card reader designed to be installed on the door frame for recognizing identification cards. Featured with the Wiegand and RS-485 outputs, the unit can be connected to any standard access control panel.
<b>GV-ASBox</b>	<b>Only works with GV-AS100 / 110 / 120.</b> The device can add Network function, 1 Wiegand interface, 8 additional inputs and outputs to GV-AS100, GV-AS110 and GV-AS120.
<b>GV-ASNet</b>	<b>Only works with GV-AS100 / 110 / 120.</b> This device can add Network function to GV-AS100, GV-AS110 and GV-AS120.

<b>GV-Hub</b>	<b>Only works with GV-AS100 / 110 / 120.</b> GV-Hub can convert the standard RS-232 signal of up to 4 controllers to RS-485, allowing the controllers to connect to computers.
<b>GV-COM</b>	<b>Only works with GV-AS100 / 110 / 120.</b> GV-COM can convert the standard RS-232 signal of one controller to RS-485, allowing the controller to connect to a computer.
<b>GV-Net / IO Card</b>	<b>Only works with GV-AS100 / 110 / 120.</b> GV-Net / IO Card can convert the standard RS-232 signal of one controller to RS-485, allowing the controller to connect to a computer.
<b>GV-IO Box</b>	<b>Only works with GV-AS400.</b> Includes the options of 4, 8 and 16 ports. Can expand GV-AS400's capability to up to 64 inputs and 64 outputs.
<b>Cabinet</b>	<b>Only available for GV-AS400 / 410 / 810 and GV-EV48.</b> With the cabinet, GV-AS / GV-EV Controllers can be mounted directly to a wall or recessed into the wall. Two types of cabinet dimensions are available (W x H x D): <ul style="list-style-type: none"> <li>• 383.5 x 443.5 x 112.2 mm / 15.1 x 17.5 x 4.4 in</li> <li>• 300 x 420 x 86 mm / 11.8 x 16.5 x 3.4 in</li> </ul>
<b>Push Button Switch</b>	The push button switch can be integrated with access control system, allowing door exit by momentarily activating or deactivating the electric locking device. Both American standard and European standard push buttons are available.
<b>GV-IB25 / 65 / 85 Infrared Button</b>	The GV-IB25 / 65 / 85 Infrared Button detects infrared movement within 3 to 12 cm and allows you to open the door with a wave of hand.
<b>Electric Lock</b>	Three types of electric locks are available: electromagnetic lock, electric bolt and electric strike.
<b>GV-AS ID Card &amp; GV-AS ID Tag</b>	GV-AS ID Cards and GV-AS ID Tags are ideal for business and residential environment, where access control is important for security reasons. 125 kHz and 13.56 MHz cards and tags are available.

# Installation Considerations

1. There are distance limitations for Wiegand and RS-485 communications. Please note:

- **Wiegand interface:** 30 meters (98.43 feet)
- **RS-485 interface:** 600 meters (1968.50 feet)

**Recommended RS-485 cable:** standard 485 cable (a twisted pair of 24 AWG wires)

2. GV-ASManager software is used to manage GV-AS / GV-EV Controllers. There is a limit for the number of controllers connected to GV-ASManager based on communication modes.

- **Through network connection,** up to 255 GV-AS / GV-EV Controllers can connect to GV-ASManager.
- **Through RS-485 connection,** up to 16 GV-AS100 / GV-AS110 / GV-AS120 Controllers can connect to the same COM port on a computer running GV-ASManager.

---

**Note:** For GV-AS100 and GV-AS400, it is highly recommended to replace the 3V lithium battery included on the circuit board.

---

## Firmware and Software Compatibility

The GV-AS / GV-EV Controllers firmware versions compatible with GV-ASManager V4.0 - V4.2.1 are listed below.

Models	GV-ASManager			
	V4.0	V4.1	V4.2	V4.2.1
GV-AS100	V1.06			V1.08
GV-AS110 / 120	V1.06			V1.07
GV-AS400	V1.04			V1.06
GV-AS410	V1.1		V1.2	V1.22
GV-AS210 / 810	V1.1 or earlier		V1.2	V1.22
GV-EV48	N/A	V1.0	V1.1	V1.11
GV-ASBox / GV-ASNet (Optional devices)	V1.06			V1.07



# **1. GV-AS100 Controller**

## 1.1 Introduction

Working as a standalone solution, GV-AS100 is a card reader with a LCD display and also a single door controller. It is possible to add one more card reader to GV-AS100 for entry and exit applications. GV-AS100 has the capability to store up to one thousand cards. When GV-AS100 is being used as a standalone unit, the programming is either done on the keypad or from the software GV-ASManager through the RS-485 connection.

GV-AS100 is suitable not only for any normal door control but also for parking gate and elevator control.

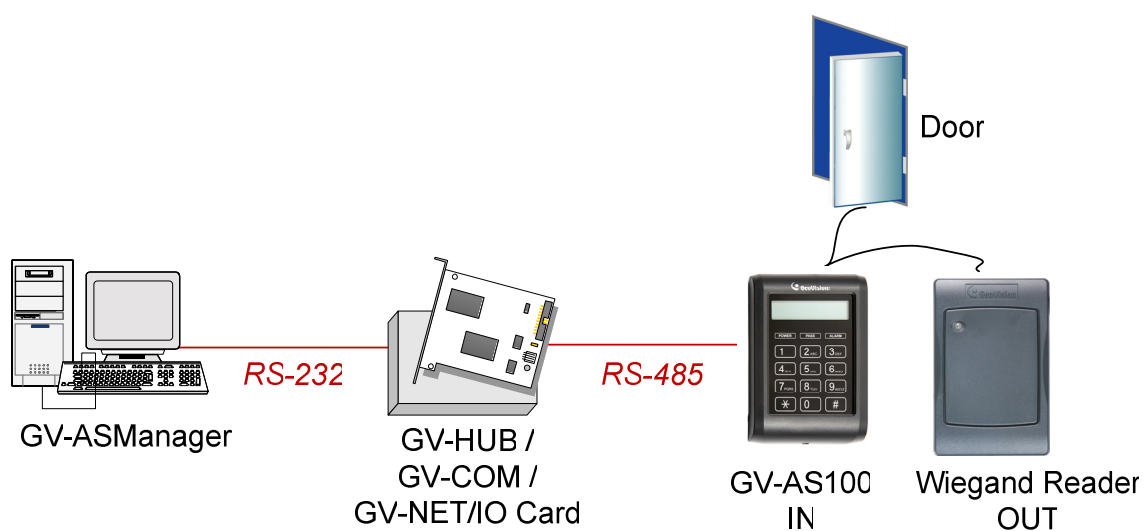

Figure 1-1

GV-AS100 can make network connection to GV-ASManager using the optional GV-ASBox or GV-ASNet. With GV-ASBox, two-door control is also possible as illustrated below.

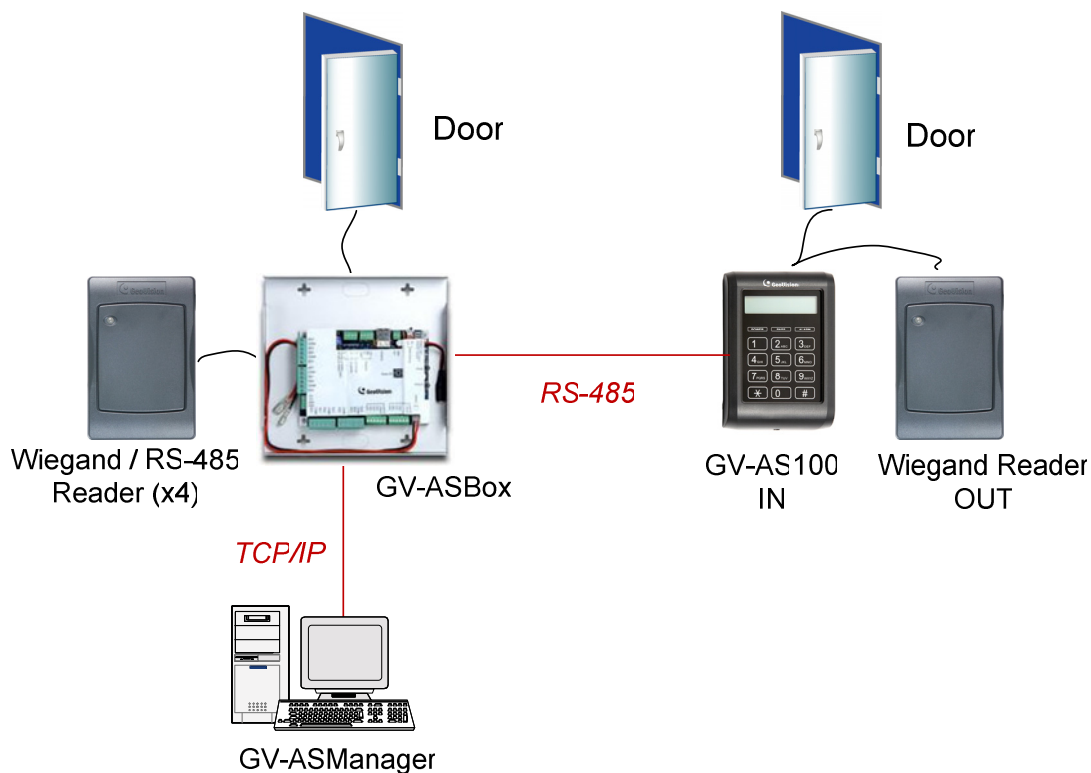

Figure 1-2 Through GV-ASBox

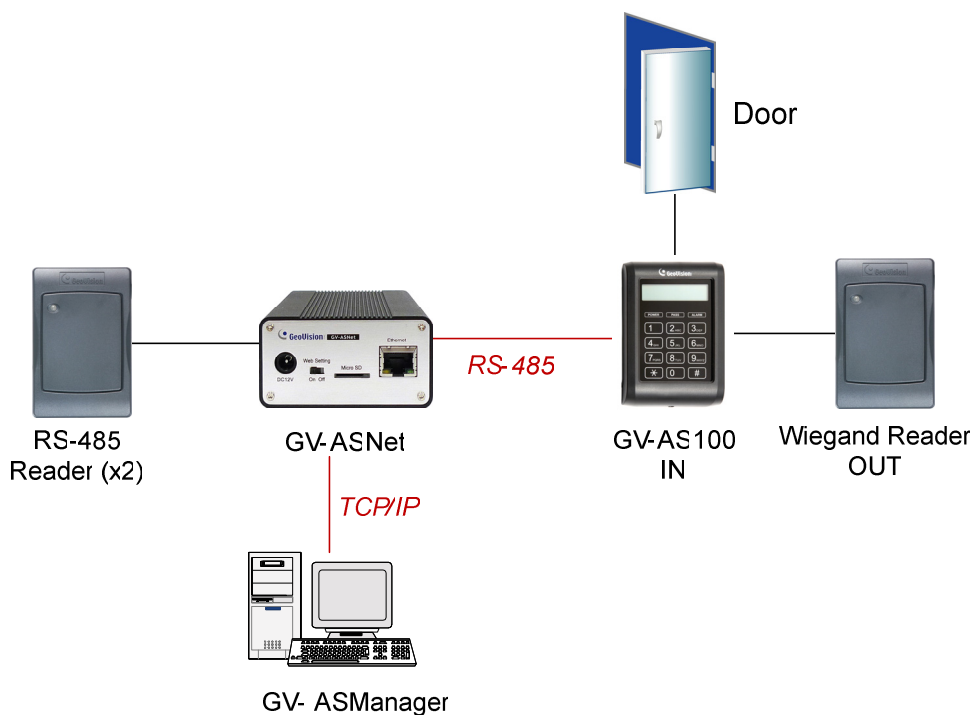

Figure 1-3 Through GV-ASNet

## 1.1.1 Main Features

- 1,000 / 40,000 cards (standalone / networked or RS-485 mode)
- Easy programming from keypad
- Anti-Passback (APB) support
- Built-in 3 digital inputs and 2 relay outputs
- 1 Wiegand output (26 ~ 64 bits) for extra reader programming
- 1 door (one-way and two-way control), expandable to 2 doors with optional GV-ASBox
- Built-in tampering alarm

## 1.1.2 Packing List

- GV-AS100
- Power Adaptor 12V DC / 1A
- Power Cord
- Screw x 3
- Screw Anchor x 2
- Master Card
- GV-ASManager Software DVD

### 1.1.3 GV-AS100 Board Layout

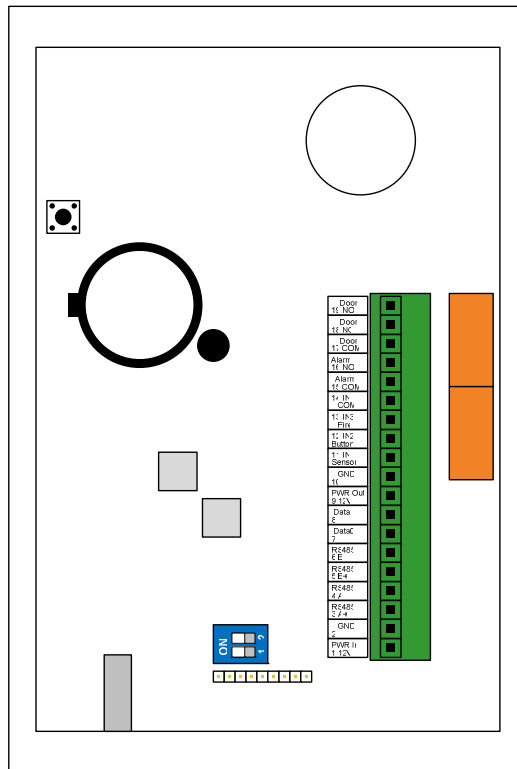

Figure 1-4

## 1.2 Installation

Please open GV-AS100 cabinet and wire the necessary connections to the terminal block as illustrated below.

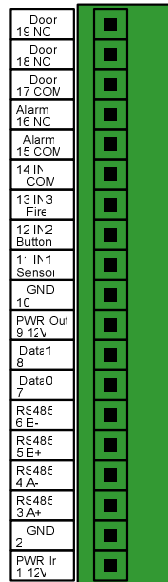

Figure 1-5

Pin	Function	Pin	Function	Pin	Function
1	12V Power	9	12V Power Supply	17	Door COM
2	GND	10	GND	18	Door NC
3	RS-485 A+ for ASBox / ASNet or PC connection	11	Sensor IN1	19	Door NO
4	RS-485 A-for ASBox / ASNet or PC connection	12	Button IN2		
5	RS-485 B+ for GV-Reader connection	13	Fire IN3		
6	RS-485 B- for GV-Reader connection	14	IN COM		
7	Wiegand Data 0	15	Alarm COM		
8	Wiegand Data 1	16	Alarm NO		

## 1.2.1 Connecting a Wiegand Reader

GV-AS100 provides one Wiegand input for connection of the Wiegand reader ranging from 26 to 64 bits. Through the GV-AS100 keypad, you can set the Wiegand reader as the entry or exit reader. To define the reader, see the **AS100 Function** option in *1.3.4 Setting Parameters*.

The table below shows the pin assignments of the Wiegand input on GV-AS100. Please consult the documentation of your Wiegand reader for wiring.

Pin	Function
7	Wiegand Data 0
8	Wiegand Data 1
9	12V Power Supply
10	GND

## 1.2.2 Connecting Input Devices

GV-AS100 supports 3 types of inputs:

1. Sensor inputs, e.g. door status sensor
2. Button inputs, e.g. door opener
3. Fire Sensor inputs, e.g. fire detector

All inputs are **dry contact** and can be configured as normally open (NO) or normally closed (NC) through the GV-AS100 keypad. The default value is **NO**. To change the input status, see the **Set Contact Type** option in *1.3.4 Setting Parameters*.

The table below shows the pin assignments of input connectors on GV-AS100.

Pin	Function
11	Sensor IN1
12	Button IN2
13	Fire Sensor IN3
14	IN COM

## 1.2.3 Connecting Output Devices

GV-AS100 supports 2 types of outputs:

1. Alarm outputs, e.g. siren or bell
2. Door outputs, e.g. electronic lock

The table below shows the pin assignments of output connectors on GV-AS100.

Pin	Function
15	Alarm COM
16	Alarm NO
17	Door COM
18	Door NC
19	Door NO

Check if your output device meets the following absolute maximum ratings before connecting it to the Door outputs.

<b>Breakdown Voltage</b>	240V AC, 30V DC
<b>Continuous Load Current</b>	5A (NO), 3A (NC)
<p><b>Note:</b> Absolute Maximum Ratings are those values beyond which damage to GV-AS100 circuit board may occur. Continuous operation of GV-AS100 at the absolute rating level may affect GV-AS100 reliability.</p>	

### To connect an output device:

The example below illustrates the connection of a locking device to GV-AS100. Connect the (+) point on the locking device to the Door COM on GV-AS100, connect the two (-) points of the locking device and the external power supply together, and connect the (+) point on the external power supply to the Door NO or Door NC on GV-AS100 based on the state of the locking device.

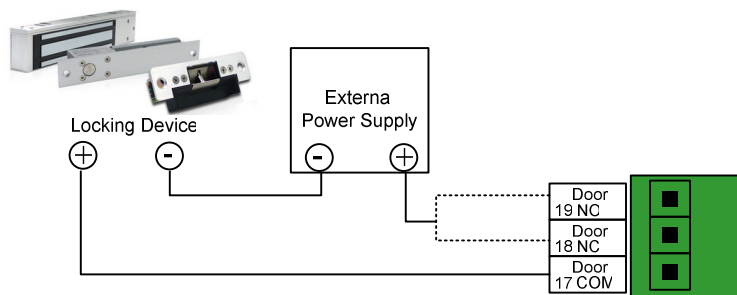

Figure 1-6



## 1.2.4 Connecting the PC

The computer running GV-ASManager software can be used to monitor the access information and alarm messages from GV-AS100. The communication link between the computer and GV-AS100 can be either through RS-485 or network. For network connection, an optional GV-ASBox or GV-ASNet is required.

---

**IMPORTANT:** To enable connecting to PC, **Switch 1** must be turned on. See *1.2.4.C Switches*.

---

### 1.2.4.A RS-485 Connection

The figure below illustrates the RS-485 connection to the computer. For this connection, a RS-485 to RS-232 converter between GV-AS100 and the computer is required. You can use GV accessories, such as GV-Hub, GV-COM and GV-NET/IO Card, as the RS-485/RS-232 converter.

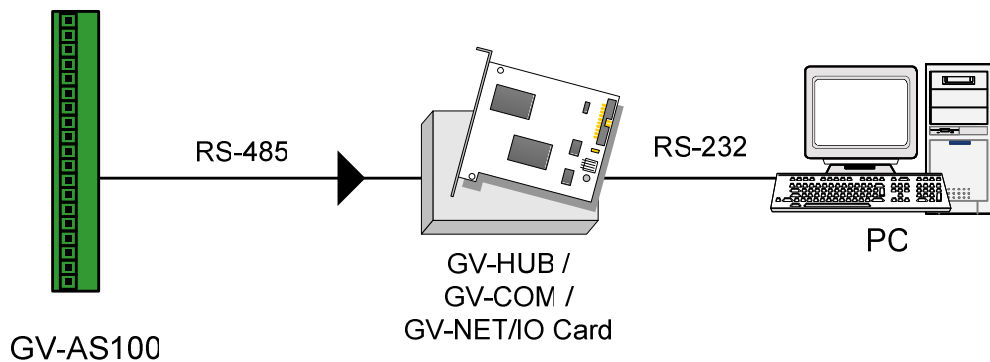

Figure 1-7

The table shows the pin assignments of related RS-485 connectors on GV-AS100.

Pin	Function
3	RS-485 A+
4	RS-485 A-

---

**Note:** When connecting multiple GV-AS100 through RS-485 connection, you can use the keypad on GV-AS100 to program every unit's ID. See *1.3.4 Setting Parameters*.

---

### 1.2.4.B Network Connection

The figure below illustrates the network connection to the computer. For this connection, the optional product GV-ASBox or GV-ASNet is required.

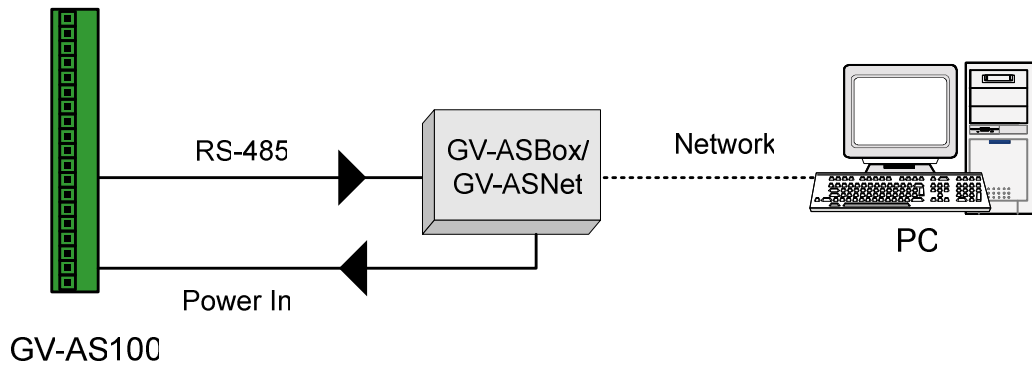

Figure 1-8

Connect two power wires and two RS-485 wires from GV-ASBox/GV-ASNet to GV-AS100. The table below shows the pin assignments of related connectors on GV-AS100.

Pin	Function	Pin	Function
1	Power In 12V	3	RS-485 A+
2	GND	4	RS-485 A-

Also see 9.1.4.A Connecting GV-AS100 / 110 / 120.

### 1.2.4.C Switches

**Switch 1:** When Switch 1 is ON, GV-AS100 can connect to GV-ASManager, GV-ASBox or GV-ASNet. When Switch 1 is OFF, the connection is unavailable. By default Switch 1 is set to **ON**.

**Switch 2:** When the RS-485 connection between GV-AS100 and computer is longer than 600 meters (1968.50 feet), the RS-485 signal may become weak. In this case, turn Switch 2 ON to have a 120-Ohm resistor.



Figure 1-9

## 1.2.5 Connecting the Power

The supplied power adaptor can be connected to any power source supplying from 100 to 240V. Using the supplied power cord and adaptor, connect GV-AS100 to the power.

---

**Note:** Power should only be applied to the unit when all connections are completed and tested.

---

## 1.2.6 Fitting the Battery

GV-AS100 includes a 3V lithium battery, providing power to GV-AS100 settings and real-time clock circuitry. When the power in the battery becomes low, the message “Low Battery” will appear on GV-AS100 LCD. In this case, please replace the battery. All settings on GV-AS100 will disappear about 10 hours after the battery stops working, and GV-AS100 will be restored to default settings.

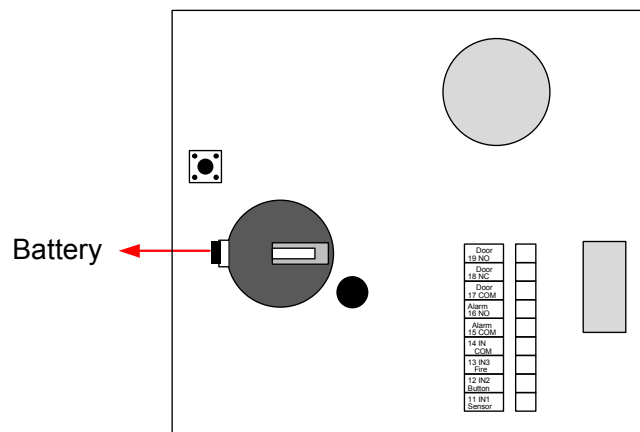

Figure 1-10

---

**Note:**

1. Make sure the plastic insulation film under the battery is removed.
  2. It is recommended to replace the battery annually.
-

## 1.3 Programming Mode

After powering on GV-AS100, you must create a Master Card first. It is required to present the Master Card and enter its PIN code every time before programming GV-AS100.

---

**Note:** The card complying with ISO 14443A standard for smart card technology can be formatted as a Master Card. Only one Master Card can be created.

---

### To create a Master Card:

1. Power on the unit. The LCD displays **Enter Master Card**.
2. Present a card to be the Master Card. The LCD displays **Master PIN Code: 1234**.
3. Keep the default PIN code as 1234, and press **#**. The LCD displays **Succeed**.

Alternatively, you can press any four digits on the keypad to change the default value.

The double confirmation of the new PIN code is required. After this, the LCD should display the message of success.

After the Master Card is created, GV-AS100 will run a self test and display the message "Master Memory Test". After it is finished, you can see the message of GV-AS100 online or offline followed by a date and time. Then you can start programming GV-AS100.

The table below shows the codes to start various programming and display system information.

Code	Function
* 227 (* CAR)	Accesses the Card Manager function.
* 276 (* ARM)	Accesses Security Mode.
* 347 (* DIS)	Displays system information.
* 738 (* SET)	Accesses parameter settings.
* 737 (* RES)	Restores GV-AS100 to factory defaults.
* 837 (* TES)	Tests numeral keys to see if they can be displayed properly.

Before programming GV-AS100, you also need to know the following keys.

<b>Key</b>	<b>Function</b>
*	Used to cancel the selection, or go back to the previous page.
#	Used to save the data that was modified or programmed in the system and quit.
0	Used to go to the next page.

### 1.3.1 Quick Reference of Programming Table

Card Manger				
	Add New Card	1) N, 2) A, 3) B, 4) S		
	Del Card Data			
	Reset Card's APB			
Display System				
	Door's Auth Mode			
	Door's Event			
	ASBox Comm. State			
	Memory's State			
	ID & IP Address			
	Display Version			
Set Parameter				
	Set Local Time			
	Set AS100 ID			
	Set Auth. Mode			
		Auth. Schedule		
		Fixed Card Mode		
		Fixed Card + PIN		
		Fixed Card Common		
		Local Unlock Mode		
		Local Lock Mode		
	AS100 Function			
		GV-ASBox		
		Control Type	Door Entry Type	Anti-Passback
			Door Exit Type	Anti-Passback
			Parking Entry Type	Anti-Passback
			Parking Exit Type	Anti-Passback
			Elevator Control	
	Master PIN Change			
	Local Rest Time			
	Set Held Open Time			
	Set Alarm Event			
		Held Open Alarm		
		Force Open Alarm		
		Fire Alarm		
		Tamper Alarm		
		Access Denied		
	Set Fire Action			
		Unlock Door/Gate		
		Lock Door/Gate		
		Unchanged		
	Set Contact Type			
		Door/Car Sensor		
		Door/Gate Button		
		Fire Sensor		

## 1.3.2 Accessing the Card Manager

The Card Manager option is used to add cards, delete cards and reset the card's APB function.

---

### Note:

1. GV-ASManager cannot manage the cards enrolled on GV-AS100, since the card data will not be transmitted to GV-ASManager.
  2. The cards added through GV-ASManager cannot be deleted on GV-AS100.
- 

### 1.3.2.A Adding a Card

Up to 1,000 cards can be enrolled on GV-AS100 directly without needing additional software. When working with GV-ASManager software, GV-AS100 can support up to 40,000 cards.

1. Press the code \***227** (\*CAR).
2. Present the Master Card and enter its PIN code. The LCD displays **Add New Card**.
3. Press **#**. The LCD displays **Enter New Card**.
4. To add a card, you can either press the card number or present the card to the unit. The LCD displays the card number and these options: **1)N 2)A 3)B 4)S**.  
**N** stands for a normal card; **A** stands for a two-person A card; **B** stands for a two-person B card; **S** stands for a security card.
5. Select a card type, and enter and confirm a PIN code for the new card.  
The LCD displays **Store New Card, 1. Yes? 2. No?**.
6. Press **1** to save and exit.

### 1.3.2.B Deleting a Card

1. Press the code \***227** (\*CAR).
2. Present the Master Card and enter its PIN code. The LCD displays **Add New Card**.
3. Press **0**. The LCD displays **Del Card Data**.
4. Press **#**. The LCD displays **Enter Del Card**.
5. You can either press the card number or present the card to the unit.  
The LCD displays: **Delete, 1. Yes? 2. No?**.
6. Press **1** to save and exit.

### 1.3.2.C Resetting the APB Function

You can reset the anti-passback (APB) function of a card to allow a user to re-access the entry or exit reader.

1. Press the code \***227** (\*CAR).
2. Present the Master Card and enter its PIN code. The LCD displays **Add New Card**.
3. Press **0** several times. The LCD displays **Reset Card's APB**.
4. Press **#**. The LCD displays **Enter Card**.
5. You can either press the card number or present the card to the unit.  
The LCD displays: **Reset, 1. Yes? 2. No?**.
6. Press **1** to save and exit.

### 1.3.3 Accessing the Security Mode

The security mode is used to arm GV-AS100. In the arm mode, no cards can be granted access and no one can program the unit. Only the security card that is associated with a PIN code can be used to disarm the unit.

#### 1.3.3.A Enabling the Security Mode

Before you can access the security mode, you need to create a security card first.

1. To create a security card, follow the steps 1 to 4 in *1.3.2.A Adding a Card*, select **4)S** as card type and create a PIN code for the security card.
2. To access security mode, press the code \***276** (\*ARM).  
The LCD displays **Start Arm? Enter PIN Code**.
3. Press the PIN code of the security card.  
The LCD displays **Start Arm? Enter Security Card**.
4. Present the security card. The security mode is enabled.

#### 1.3.3.B Disabling the Security Mode

To disable the security mode, press any key, enter the PIN code of the security card and present the security card.



### 1.3.4 Setting Parameters

You can define the parameters of some features on GV-AS100.

---

**IMPORTANT:** Once connecting to GV-AS100, GV-ASManager will load its parameters to GV-AS100. That means some of the parameters you set up here may be overwritten by GV-ASManager later.

---

1. Press the code \***738** (\***SET**).
2. Present the Master Card and enter its PIN code. The LCD displays **Set Local Time**.
3. Press **0** to change the options. Press **#** to select the option for further programming.

Option	Function
Set Local Time	Sets the time, time zone and enables daylight saving.
Set AS100 ID	Sets the ID of GV-A100 from 1 to 255.
Set Auth. Mode	<p>Sets an authentication mode for the door/gate.</p> <ul style="list-style-type: none"> <li>■ <b>Auth. Schedule:</b> Follows the authentication schedule set on GV-ASManager.</li> <li>■ <b>Fixed Card Mode:</b> Grants access after the card is presented. Ignores the authentication schedule of GV-ASManager.</li> <li>■ <b>Fixed Card + PIN:</b> Grants access after the user presents the card and then enters the card's PIN code. Ignores the authentication schedule of GV-ASManager.</li> <li>■ <b>Fixed Card/Common:</b> Grants access after the user presents the card or enters the door's password. Enter the door's password after the LCD displays <b>Common Password</b>. Ignores the authentication schedule of GV-ASManager.</li> <li>■ <b>Local Unlock Mode:</b> Remains open. The held-open state cannot be cleared through GV-ASManager.</li> <li>■ <b>Local Lock Mode:</b> Remains locked. The locked state cannot be cleared through GV-ASManager.</li> </ul>

AS100 Function	<ul style="list-style-type: none"> <li>■ <b>GV-ASBox:</b> Enables or disables the connection to GV-ASBox / GV-ASNet.</li> <li>■ <b>Control Type:</b> <ul style="list-style-type: none"> <li>⊙ <b>Door Entry Type:</b> Sets GV-AS100 as entry reader of a door. The Wiegand reader connected will be set as exit reader.</li> <li>⊙ <b>Door Exit Type:</b> Sets GV-AS100 as exit reader of a door. The Wiegand reader connected will be set as entry reader.</li> <li>⊙ <b>Parking Entry Type:</b> Sets GV-AS100 as entry reader of a parking gate.</li> <li>⊙ <b>Parking Exit Type:</b> Sets GV-AS100 as exit reader of a parking gate.</li> <li>⊙ <b>Elevator Type:</b> GV-AS100 reader is installed in the elevator for access control.</li> </ul> </li> <li>■ <b>Anti-Passback:</b> Enables or disables the Anti-Passback function.</li> </ul>
Master PIN Change	Changes the PIN code of the Master Card.
Local Rest Time	Sets the time (1 to 255 sec.) that a door/gate remains open after which the door will automatically be locked.
Set Held Open Time	Sets the time (5 to 9999 sec.) that a door/gate can be held open before an alarm is generated.
Set Alarm Event	Enables or disables the alarm settings.
Set Fire Action	Locks or unlocks the door/gate, or remains the current state when a fire condition occurs.
Set Contact Type	Sets the inputs to be normally open (NO) or normally closed (NC).

---

**Note:** The **Parking Entry Type** and **Parking Exit Type** only work when the sensor input of Car Detection is activated. When the card is present but the sensor inputs are not activated, the message “No Car In Zone” will appear in the GV-AS100’s LCD.

---

### 1.3.5 Displaying System Information

To display system information, press the code \*347 (\*DIS).

Option	Function
Door's Auth. Mode	Displays the authentication mode of the door.
Door's Event	Displays what kind of event happened at the door.
ASBox Comm. State	<p>Displays the connection status with GV-ASBox / GV-ASNet.</p> <ul style="list-style-type: none"> <li>■ <b>User Disenable:</b> The connection to GV-ASBox / GV-ASNet is not enabled.</li> <li>■ <b>Comm. Fail:</b> The connection to GV-ASBox / GV-ASNet failed.</li> <li>■ <b>Comm. Normal:</b> The connection to GV-ASBox / GV-ASNet succeeded.</li> </ul>
Memory's State	<p>Displays the memory usage of GV-AS100.</p> <ul style="list-style-type: none"> <li>■ <b>Capacity:</b> Displays the total number of events that can be recorded on GV-AS100. The maximum number is <b>65536</b>. GV-AS100 will overwrite the oldest events when the limit is reached. When GV-AS100 is connected to GV-ASManager, the event data will be uploaded to the server and the buffer of GV-AS100 will be cleared.</li> <li>■ <b>Stored:</b> Displays the number of events that has been recorded.</li> </ul>
ID & IP Address	Displays the ID and IP address of GV-AS100.
Display Version	Displays the firmware version of GV-AS100.

## 1.3.6 Restoring Factory Defaults

The restore function is used to clear all configured options and cards from GV-AS100 memory and bring back the unit to factory defaults.

---

**IMPORTANT:** Restoring default settings will delete all cards enrolled on GV-AS100.

---

1. Press the code \***737** (\*RES).
2. Present the Master Card and enter PIN Code.  
The LCD displays **Default Setting 1. Yes? 2. No?**.
3. Press **1**. The LCD displays **Default Setting Memory Test...**
4. When the unit returns to factory defaults, the LCD displays **Enter Master Card**.

## 1.4 Web-Based Configurations

Through GV-ASBox or GV-ASNet, GV-AS100 can communicate with GV-ASManager over the network. Using GV-ASBox or GV-ASNet, you can also access the Web interface of GV-AS100.

Refer to *Chapter 10 Optional Devices* to see how to connect a GV-ASBox or GV-ASNet and how to access the Web interface of GV-AS100.

## 1.5 GV-AS100 Specifications

CPU	8-bit RISC microprocessor	
Number of User Cards	1,000 / 40,000 cards (standalone / networked or RS-485 mode)	
Frequency	13.56 MHz for ISO14443A (Mifare DESFire, Mifare Plus and Mifare Classic)	
Event Buffer	65,536 events and log data	
Power	100 ~ 240V AC, 50 ~ 60Hz	
Wiegand Interface	1 Wiegand interface, 26 ~ 64 bit format	
	12V DC Power Supply, 200mA	
Communication Protocol	RS-485	
Digital I/O	Input	3 inputs, dry contact, NO / NC
	Output	2 outputs
Operating Temperature	0 ~ 65°C / 32 ~ 149°F	
Operating Humidity	10% ~ 90% RH (non-condensing)	
Dimensions (W X H X D)	96 x 137 x 27 mm / 3.78 x 5.39 x 1.06 in	
Weight	250 g / 0.55 lb	
Certification	IP54, CE, FCC, RoHS	

All specifications are subject to change without notice.

## **2. GV-AS110 Controller**

## 2.1 Introduction

Working as a standalone solution, GV-AS110 is a card reader and also a single door controller. It is possible to add one more card reader to GV-AS110 for entry and exit applications. GV-AS110 has the capability to store up to one thousand cards. When GV-AS110 is being used as a standalone unit, the programming is either done on the keypad or from the software GV-ASManager through the RS-485 connection.

GV-AS110 is suitable not only for any normal door control but also for parking gate and elevator control. GV-AS110 is an economic solution for access control.

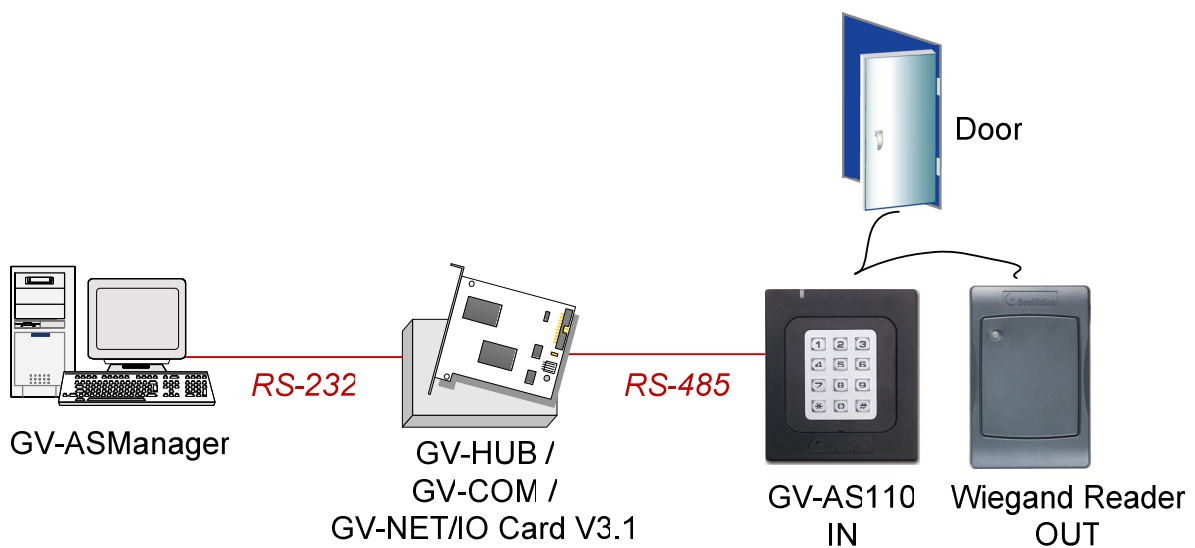

Figure 2-1



GV-AS110 can make network connection to GV-ASManager using the optional GV-ASBox or GV-ASNet. With GV-ASBox, two-door control is also possible as illustrated below.

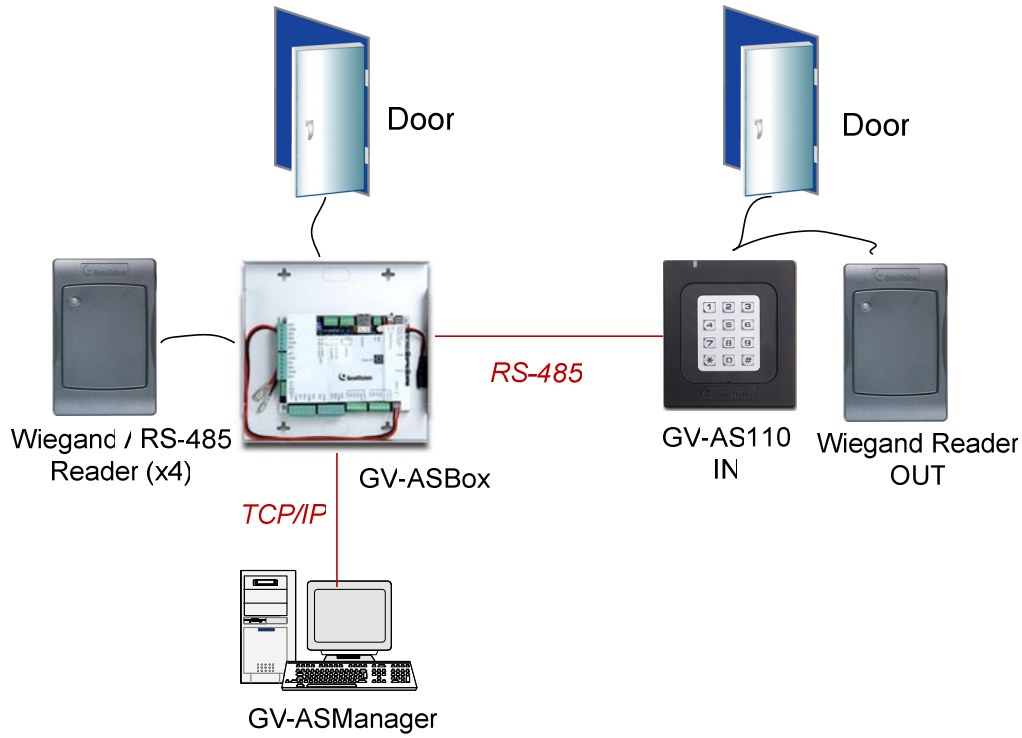

Figure 2-2 Through GV-ASBox

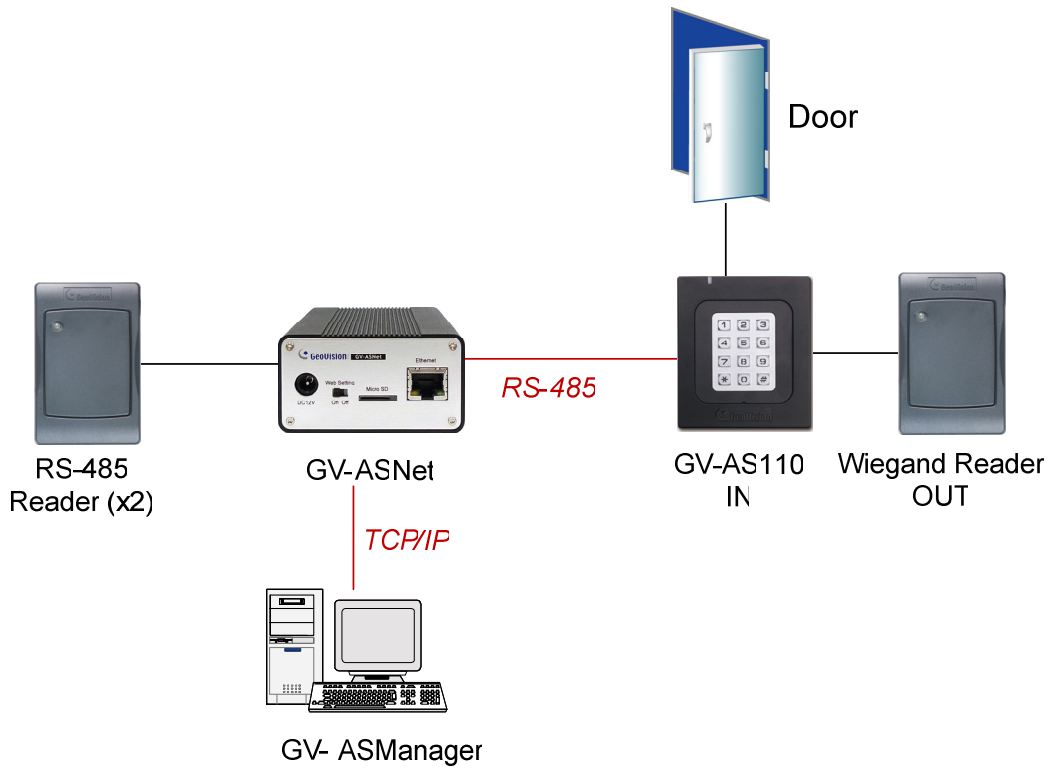

Figure 2-3 Through GV-ASNet

## 2.1.1 Main Features

- 1 door (one-way and two-way control), expandable to 2 doors with optional GV-ASBox
- 1,000 / 40,000 cards (standalone / networked or RS-485 mode)
- Easy programming from keypad
- Anti-Passback (APB) support
- Built-in 3 digital inputs and 2 relay outputs
- 1 Wiegand output (26 ~ 64 bits) for extra reader programming
- Built-in tampering alarm

## 2.1.2 Packing List

- GV-AS110
- Power Adaptor 12V DC / 1.25A
- Power Cord
- Screw x 2
- Screw Anchor x 2
- Front Cover Plate x 2
- Enroll Card
- Delete Card
- GV-ASManager Software DVD

## 2.2 Installation

The wire assignment of the GV-AS110 cable data are illustrated below.

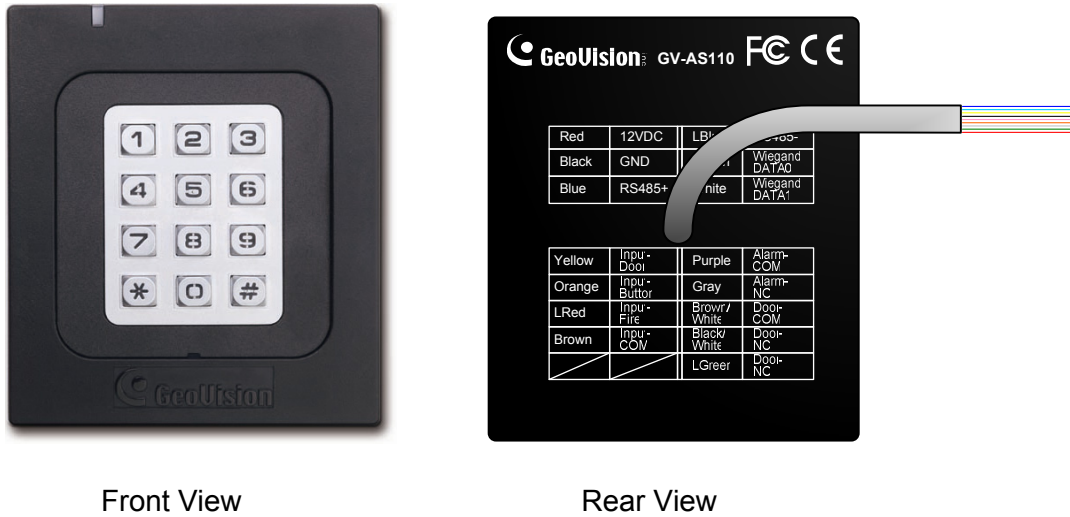

Figure 2-4

Wire color	Definition
Red	12V
Black	GND
Green	Wiegand Data 0
White	Wiegand Date 1
Blue	RS485+
Light Blue	RS485-
Yellow	Door Sensor IN1
Orange	Button IN2
LRed	Fire Sensor IN3
Brown	IN COM (GND)
Purple	Alarm COM
Gray	Alarm NO
Brown White	Door COM
Black White	Door NC
Light Green	Door NO

## 2.2.1 Connecting a Wiegand Reader

GV-AS110 provides one Wiegand input for connection to the Wiegand reader ranging from 26 to 64 bits. Through the GV-AS110 keypad, you can set the Wiegand reader as the entry or exit reader. To define the reader, see the **Door/Gate Function** option in 2.3.2 *Programming the GV-AS110*.

The table below shows the wire assignments of the Wiegand input on GV-AS110. Please consult the documentation of your Wiegand reader for wiring. You will need to set up a separate power source to power the Wiegand reader.

Wire color	Definition
Green	Wiegand Data 0
White	Wiegand Data 1

## 2.2.2 Connecting Input Devices

GV-AS110 supports 3 types of inputs:

1. Sensor inputs, e.g. door status sensor
2. Button inputs, e.g. door opener
3. Fire Sensor inputs, e.g. fire detector

All inputs are **dry contact** and can be configured as normally open (NO) or normally closed (NC) through the GV-AS110 keypad. The default value is **NO**. To change the input status, see the **Select Input Contact Type** option in 2.3.2 *Programming the GV-AS110*.

The table below shows the wire assignments of input connectors on GV-AS110.

Wire color	Definition
Yellow	Door Sensor IN1
Orange	Button IN2
LRed	Fire Sensor IN3
Brown	IN COM (GND)

## 2.2.3 Connecting Output Devices

GV-AS110 supports 2 types of outputs:

1. Alarm outputs, e.g. siren or bell
2. Door outputs, e.g. electronic lock

The table below shows the wire assignments of output connectors on GV-AS110.

Wire color	Definition
Purple	Alarm COM
Gray	Alarm NO
Brown & White	Door COM
Black & White	Door NC
Light green	Door NO

Check if your output device meets the following absolute maximum ratings before connecting it to the Door outputs.

<b>Breakdown Voltage</b>	250V AC, 220V DC
<b>Continuous Load Current</b>	1A (30V DC), 0.3A (125V AC)
<p><b>Note:</b> Absolute Maximum Ratings are those values beyond which damage to GV-AS110 circuit board may occur. Continuous operation of GV-AS110 at the absolute rating level may affect GV-AS110's reliability.</p>	

### To connect an output device:

The example below illustrates the connection of a locking device to GV-AS110. Connect the (+) point on the locking device to the Door COM wire on GV-AS110, connect the two (-) points of the locking device and the external power supply together, and connect the (+) point on the external power supply to the Door NO or Door NC wire on GV-AS110 based on the state of the locking device.

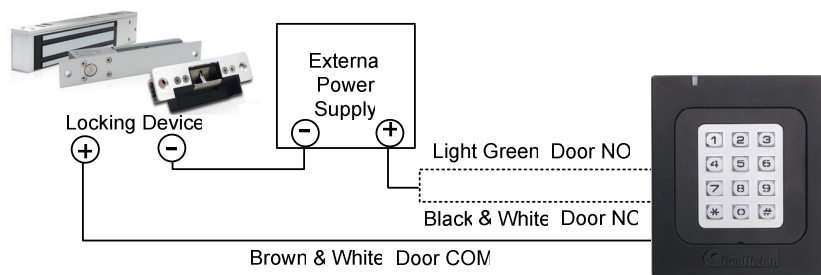

Figure 2-5

## 2.2.4 Connecting to the PC

The computer running GV-ASManager software can be used to monitor the access information and alarm messages from GV-AS110. The communication link between the computer and GV-AS110 can be either through RS-485 or network. For RS-485 connection, a RS-485 to RS-232 converter is required. For network connection, an optional GV-ASBox or GV-ASNet is required.

### 2.2.4.A RS-485 Connection

The figure below illustrates the RS-485 connection to the computer. For this connection, a RS-485 to RS-232 converter between GV-AS110 and the computer is required. You can use GV accessories, such as GV-Hub, GV-COM and GV-NET/IO Card, as the RS-485/RS-232 converter.

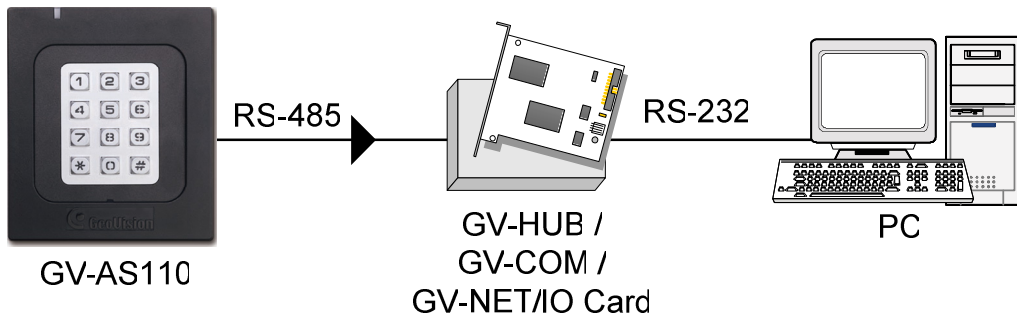

Figure 2-6

The table shows the wire assignments of RS-485 connection on GV-AS110.

Wire color	Definition
Blue	RS485 A+
Light Blue	RS485 A-

---

**Note:** When connecting multiple GV-AS110 through RS-485 connection, you can use the keypad on GV-AS110 to program every unit's ID. See 2.3.2 *Programming the GV-AS110*.

---

### 2.2.4.B Network Connection

The figure below illustrates the network connection to the computer. For this connection, a GV-ASBox or GV-ASNet is required.

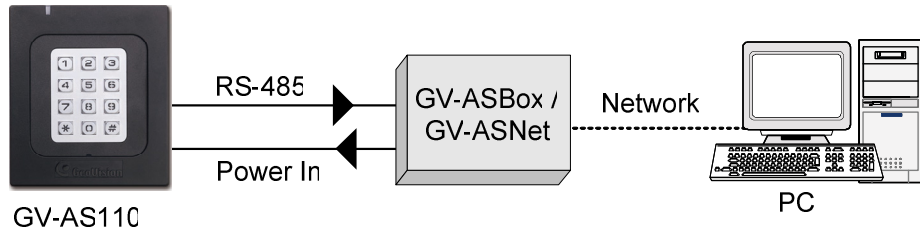

Figure 2-7

Connect two power wires and two RS-485 wires from GV-AS110 to GV-ASBox / GV-ASNet. The table below shows the wire assignments of RS-485 connection on GV-AS110.

Wire color	Definition
Red	12V
Black	GND
Blue	RS485 A+
Light Blue	RS485 A-

See 9.1.4.A Connecting GV-AS100 / 110 / 120 or 9.2.4A Connecting GV-AS100 / 110 / 120 to see how to connect to GV-ASBox or GV-ASNet.

### 2.2.5 Connecting the Power

The supplied AC adaptor can be connected to any power source supplying from 100 to 240V. Connect 12V and GND wires to the supplied power adapter and then connect the power adapter to a power source. The table below shows the pin assignments of the power connectors on GV-AS110.

Wire color	Definition
Red	12V
Black	GND

---

**Note:** Power should only be applied to the unit when all connections are completed and tested.

---

## 2.3 Programming Mode

After powering on GV-AS110, you must create two cards first, an Enroll Card and a Delete Card. The Enroll Card is used for adding new cards and the Delete Card is used for deleting cards. Either card will allow you to program the various configurations on GV-AS110.

---

**Note:** The card complying with ISO 14443A standard for smart card technology can be formatted as an Enroll Card or Delete Card.

---

### To create the Enroll Card and the Delete Card:

1. Power on the unit. The LED flashes blue.
2. Present a card to be the Enroll Card.
3. Present a card to be the Delete Card.
4. The GV-AS110 will automatically load default, and the LED will flash blue and yellow.  
After 1 to 2 minutes, the LED should be a constant blue light to indicate READY.

### 2.3.1 Adding and Deleting Cards

Using the two cards, you can add new cards to GV-AS110 and delete existing cards on GV-AS110.

---

#### **Note:**

1. GV-ASManager cannot manage the cards enrolled on GV-AS110, since the card data will not be transmitted to GV-ASManager.
  2. The cards added through GV-ASManager cannot be deleted on GV-AS110.
-



### 2.3.1.A Adding a Card

Up to 1,000 cards can be enrolled on GV-AS110 directly without needing additional software. When working with GV-ASManager software, GV-AS110 can support up to 40,000 cards.

1. Present the Enroll Card.
2. Enter a 4-digit PIN code for the new card, reenter the same 4-digit PIN code and then enter the command code for a desired type of card listed below. The LED will blink green and red for about 10 seconds. You must finish entering the PIN code twice and the card command code within the 10 seconds.

Code	Types of Cards	Description
0	Normal Card	The door unlocks after a card is presented. Normal Cards will not be granted access when Two Person Entrance/Exit or Security Mode is enabled.
1	Two-person A Card	In the Two Person Entrance/Exit mode, the door unlocks only when two-person B card is also presented together.
2	Two-person B Card	In the Two Person Entrance/Exit mode, the door unlocks only when two-person A card is also presented together.
3	Security Card	The Security Card is used for launching the Security Mode, in which no cards can be granted access and no one can program the unit. Only the Security Card will be able to disable the Security Mode.

3. Present the card you want to add to the GV-AS110.
4. The GV-AS110 will produce a long beep if the card has been added successfully and three short beeps if the adding procedure has failed.

If you do not want to customize a password, you can simply present the Enroll Card and then present the card you would like to add. The default password will be 1234 and the card will automatically be set to a Normal Card.

### 2.3.1.B Deleting a Card

1. Present the Delete Card.
2. Present the card you want to delete.
3. The GV-AS110 will produce a long beep if the card has been deleted successfully and three short beeps if the deleting procedure has failed.

## 2.3.2 Programming the GV-AS110

The command codes used to program various functions on GV-AS110 are listed below. All command codes will start with an asterisk \* to clear all previous commands and end with a number sign # to send the command. After typing the command code, present the Enroll Card or the Delete Card.

---

**IMPORTANT:** Once connecting to GV-AS110, GV-ASManager will load its parameters to GV-AS110. That means some of settings you program here may be overwritten by GV-ASManager later.

---

Function	Command Code	Description
<b>Set Password</b>	*779_ _ _ _ _ # 4-8 digits	You can set a password to open the door using this password. The Authentication Mode must be set to <b>Fixed Card/Common</b> mode. Refer to the <b>Set Authentication Mode</b> function below.  For example, to set the door's password as 12345, press *77912345# on the keypad.
<b>Lock Reset Time</b>	*578_ _ _ # 1-255 seconds	Sets a time that the door/gate will remain open after which the door will automatically be locked.  For example, to set the lock reset time to be 120 seconds, press *578120#
<b>Held Open Time</b>	*468_ _ _ _ # 5-9999 seconds	Sets the time that a door/gate can be held open before an alarm is generated. If the number of seconds is less than 4 digits, add zeros in front of the number to make it 4 digits.  For example, to set the held open time to be 180 seconds, enter *4680180#
<b>Set Fire Action</b>	*732_# Unchanged→0 Unlock Door→1 Lock Door→2	This function locks or unlocks the door/gate, or maintains the current status when a fire emergency occurs.  For example, to unlock door during a fire emergency, press *7321#
<b>Local Anti-Passback</b>	*527_# 0→Disable 1→Enable	Local Anti-passback prevents card sharing by not allowing a card to go through an entry twice before first exiting.  For example, to enable Local Anti-passback, press *5271#

<p><b>Set Alarm Event</b></p>	<p>*723_ _ _ _#                  Held Open → 0                  Forced Open → 1                  Tamper → 2                  Fire Alarm → 3                  Access Denied → 4                  Alarm Time → 1-10 sec</p>	<p>For the first blank digit, enter a number from options 0 to 4. For the second blank digit, type 1 to enable the option and 0 to disable the option. For the third and fourth blank digits, type the number of seconds the alarm will sound.</p> <p>For example, to enable the fire alarm for 3 seconds, press *7233103#</p>
<p><b>Door/Gate Function</b></p>	<p>*343_#                  Door Entry Type→0                  Parking Entry Type→1                  Door Exit Type→2                  Parking Exit Type→3                  Elevator Type→4</p>	<ul style="list-style-type: none"> <li>■ <b>Door Entry Type:</b> Sets GV-AS110 as entry reader of a door. The Wiegand reader connected will be set as exit reader.</li> <li>■ <b>Parking Entry Type:</b> Sets GV-AS110 as entry reader of a parking gate.</li> <li>■ <b>Door Exit Type:</b> Sets GV-AS110 as exit reader of a door. The Wiegand reader connected will be set as entry reader.</li> <li>■ <b>Parking Exit Type:</b> Sets GV-AS110 as exit reader of a parking gate.</li> <li>■ <b>Elevator Type:</b> GV-AS110 reader is installed in the elevator for access control.</li> </ul> <p>For example, to set the GV-AS110 as an exit reader of a door, press *3432#</p>
<p><b>Set Authentication Mode</b></p>	<p>*526_#                  Schedule Mode→0                  Fixed Card Mode→1                  Local Lock Mode→2                  Local Unlock Mode→3                  Fixed Card + PIN→4                  Fixed Card/Common→5</p>	<ul style="list-style-type: none"> <li>■ <b>Schedule Mode:</b> Follows the authentication schedule set on GV-ASManager.</li> <li>■ <b>Fixed Card Mode:</b> Grants access after the card is presented. Ignores the authentication schedule of GV-ASManager.</li> <li>■ <b>Local Lock Mode:</b> Remains locked. The locked state cannot be cleared through GV-ASManager.</li> <li>■ <b>Local Unlock Mode:</b> Remains open. The held-open state cannot be cleared through GV-ASManager.</li> <li>■ <b>Fixed Card + PIN:</b> Grants access after the user presents the card and then enters the card's PIN code. Ignores the authentication schedule of GV-ASManager.</li> <li>■ <b>Fixed Card/Common:</b> Grants access after card is presented or after the door's password is entered. Ignores the authentication schedule of GV-ASManager.</li> </ul>

		For example, to enable the Fixed Card + PIN mode, press <b>*5264#</b> .
<b>Open door with card number and PIN code</b>	<b>*_____(_)_#</b> Enter the 8-digit card number and enter its 4-digit PIN code.	To open the door without presenting a card, enter the 8-digit card number on the back of the individual card and its 4-digit PIN code.
<b>Set ID</b>	<b>*743__#</b> Enter an ID number between 0 and 255.	Set an ID number for GV-AS110 to a number between 0 and 255. For example, to set the ID number to be 3, press <b>*743003#</b>
<b>Security Mode</b>	<b>*276___#</b> 4 digits PIN code of the security card.	In the Security Mode, no cards can be granted access and no one can program the unit. Only the Security Card can disable the Security Mode.  To enable the Security Mode, press <b>*276</b> , enter the PIN code of the Security Card and press <b>#</b> . Present the Security Card.  To disable the Security Mode, simply press the PIN code of the Security Card and present the Security Card.
<b>Two Person Entrance</b>	<b>*873_#</b> Disable→0 Enable→1	When Two Person Entrance mode is enabled, both Two Person A Card and Two Person B Card must be presented to unlock the entrance.  To enable Two Person Entrance, press <b>*8731#</b>
<b>Two Person Exit</b>	<b>*879_#</b> Disable→0 Enable→1	When Two Person Exit mode is enabled, both Two Person A Card and Two Person B Card must be presented to unlock the exit.  To enable Two Person Exit, press <b>*8791#</b>
<b>Select Input Contact Type</b>	<b>*426__#</b> NO→1 NC→0	Specify the input contact type of the <b>door sensor</b> in the first blank digit, <b>button</b> in the second blank digit and <b>fire sensor</b> in the third blank digit. The default value is normally opened (NO).  For example, to set the input contact type for door sensor to be normally open (NO), button to be normally closed (NC), and fire sensor to be normally open (NO), press <b>*426101#</b> .
<b>Load Default</b>	<b>*362#</b>	To restore GV-AS110 to factory default, press <b>*362#</b> . All configured settings will be cleared and all cards will be deleted from GV-AS110.

**Note:** The **Parking Entry Type** and **Parking Exit Type** only work when the sensor input of Car Detection is activated.

## 2.4 LED Status and Beeper

Normally, the LED on GV-AS110 is blue during standby mode and the LED flashes green when a card is granted access or when the operation was successful. A red LED indicates access denied or the operation was unsuccessful. The LED status and beeper under different conditions are listed below.

Condition	LED	Beeper
Card + PINCode Mode	Flashes blue	Silent
Card Mode	Constant blue	Silent
Release Mode	Flashes green	Silent
Force Unlock Mode	Flashes green	Silent
Fire Unlock Mode	Flashes green	Silent
Force Lock Mode	Flashes red	Silent
Fire Lock Mode	Flashes red	Silent
Security Mode enabled	Yellow	One long beep
Security Mode disabled	Returns to the LED status of the previous mode	One long beep
Tamper / Forced Open Alarm	Flashes green and red	Constant beep until alarm cancelled
Fire Alarm	Red	Constant beep until alarm cancelled
Held Open Alarm	Unchanged	Constant beep until alarm cancelled
Access Denied Alarm	Flashes red momentarily	Short beep for the number of seconds specified
Access Denied	Flashes red momentarily	Two short beeps
Access Granted	Flashes green momentarily	One short beep
Enroll Card	Flashes green momentarily	Two long beeps
Delete Card	Flashes red momentarily	Two long beeps
Enrolled/Deleted card successfully	Displays green LED momentarily	One long beep
Enroll/Delete card failed	Displays red LED momentarily	Three short beeps

Firmware update	Flashes red, green and blue	Silent
Firmware update failed	Flashes purple	Constant beep
Factory default	Flashes blue	Silent

## 2.5 Web-Based Configurations

Through GV-ASBox or GV-ASNet, GV-AS110 can communicate with GV-ASManager over the network. Using GV-ASBox or GV-ASNet, you can also access the Web interface of GV-AS110.

Refer to *Chapter 10 Optional Devices* to see how to connect a GV-ASBox or GV-ASNet and how to access the Web interface of GV-AS110.

## 2.6 GV-AS110 Specifications

CPU	32-bit RISC microprocessor	
Number of User Cards	1,000 / 40,000 cards (standalone / networked or RS-485 mode)	
Frequency	13.56 MHz for ISO14443A (Mifare DESFire, Mifare Plus and Mifare Classic)	
Event Buffer	65,536 events and log data	
Power	100 ~ 240V AC, 50 ~ 60Hz	
Wiegand Interface	1 Wiegand interface, 26 ~ 64 bit format	
	12V DC Power Supply, 200mA	
Communication Protocol	RS-485	
Digital I/O	Input	3 inputs, dry contact, NO / NC
	Output	2 outputs
Operating Temperature	-35 ~ 65°C / -31 ~ 149°F	
Operating Humidity	10% ~ 90% RH (non-condensing)	
Dimensions (W X H X D)	95 x 108 x 23 mm / 3.74 x 4.25 x 0.91 in	
Weight	200 g / 0.44 lb	
Certification	IP54, CE, FCC, RoHS	

All specifications are subject to change without notice.



### **3. GV-AS120 Controller**

### 3.1 Introduction

Working as a standalone solution, GV-AS120 is a card reader and also a single door controller. It is possible to add one more card reader to GV-AS120 for entry and exit applications. GV-AS120 has the capability to store up to one thousand cards. When GV-AS120 is being used as a standalone unit, the programming is done from the software GV-ASManager through the RS-485 connection.

GV-AS120 is suitable not only for any normal door control but also for parking gate and elevator control. GV-AS120 is an economic solution for access control.

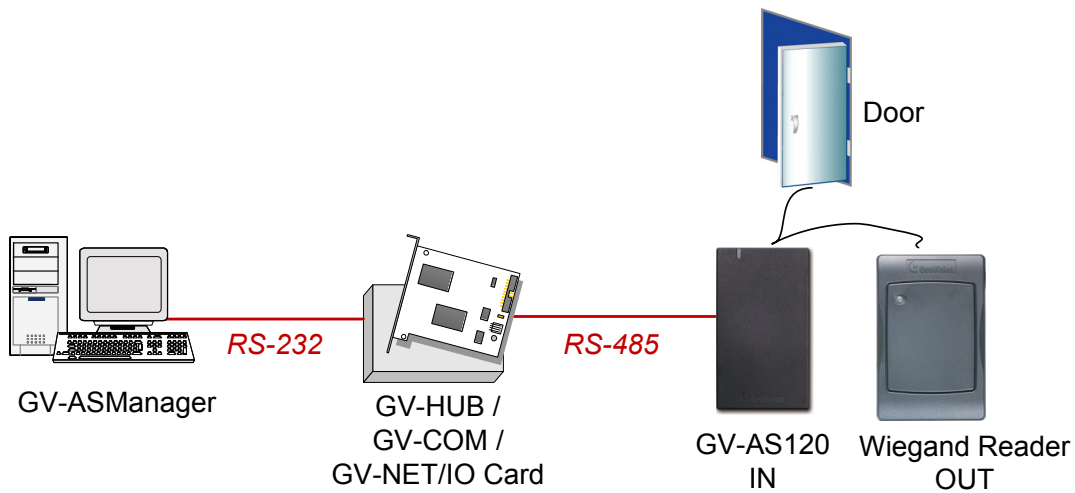

Figure 3-1

GV-AS120 can make network connection to GV-ASManager using the optional GV-ASBox or GV-ASNet. With GV-ASBox, two-door control is also possible as illustrated below.

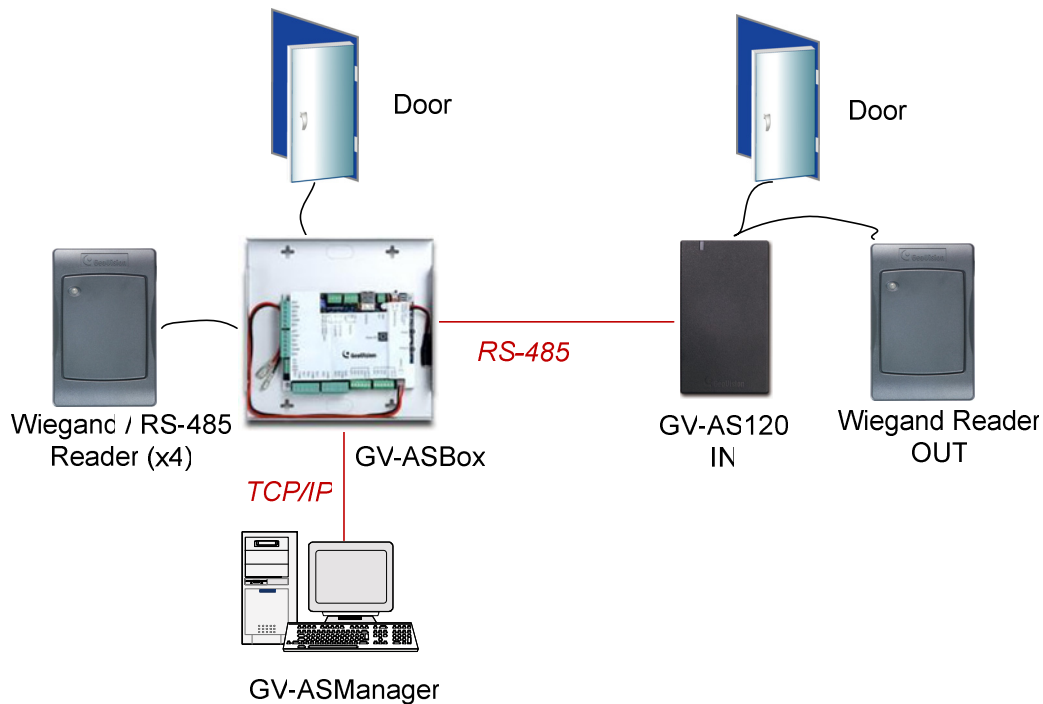

Figure 3-2 Through GV-ASBox

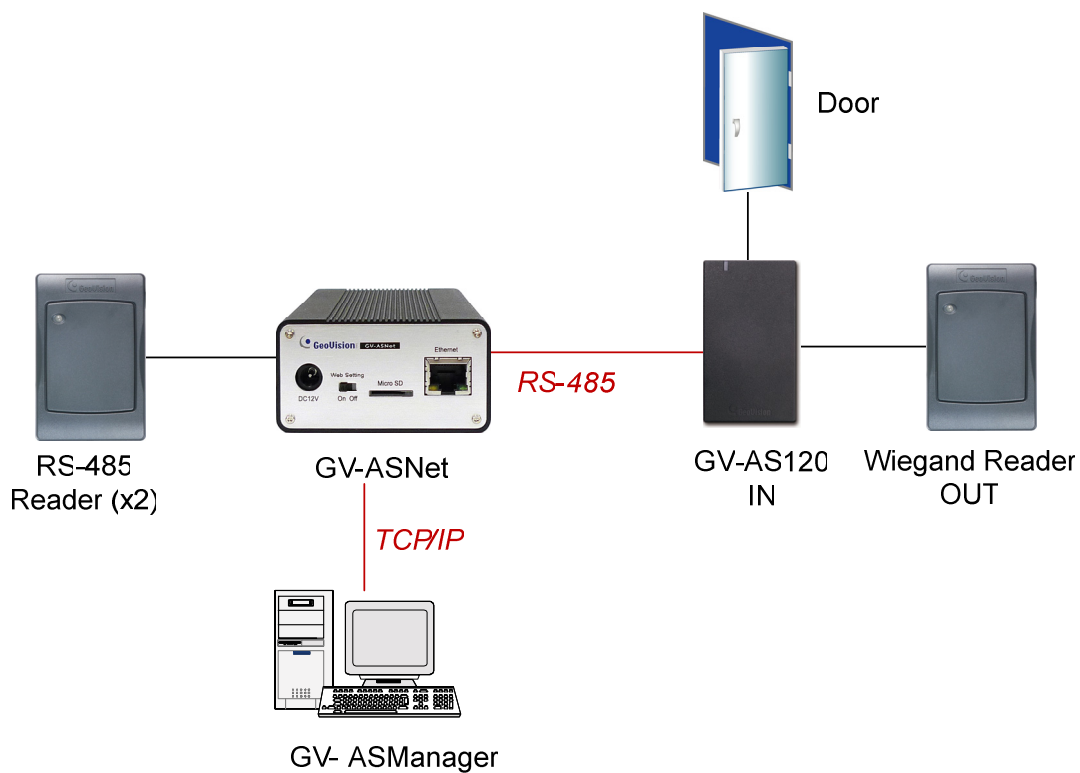

Figure 3-3 Through GV-ASNet

### **3.1.1 Main Features**

- 1 door (one-way and two-way control), expandable to 2 doors with optional GV-ASBox
- 1,000 / 40,000 cards (standalone / networked or RS-485 mode)
- Built-in 2 digital inputs and 1 relay output
- 1 Wiegand output (26 ~ 64 bits) for extra reader programming
- Built-in tampering alarm
- Weather-proof and IP66-compliant housing (for outdoor use)

### **3.1.2 Packing List**

- GV-AS120
- Power Adaptor 12V DC / 1.25A
- Power Cord
- Screw x 3
- Screw Anchor x 2
- Security Torx
- Enroll Card
- Delete Card
- GV-ASManager Software DVD

## 3.2 Installation

The wire assignment of the GV-AS120 cable data are illustrated below.

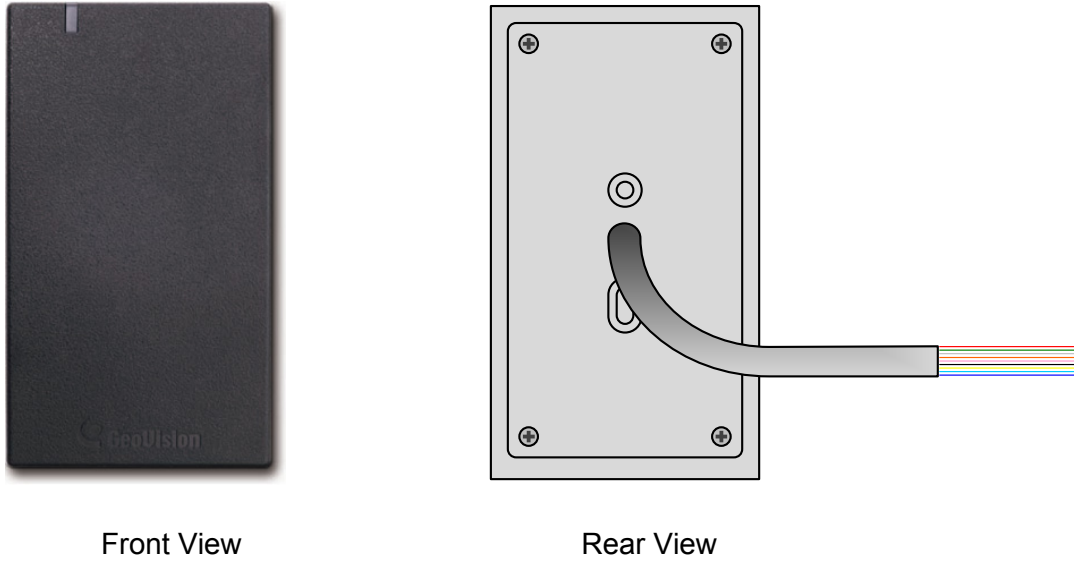

Figure 3-4

Wire color	Definition
Red	12V
Black	GND
Green	Wiegand Data 0
White	Wiegand Date 1
Blue	RS485+
Light Blue	RS485-
Brown	IN COM (GND)
Yellow	Door Sensor IN1
LRed	Button IN2
Purple	Door COM
Orange	Door NC
Gray	Door NO

### 3.2.1 Connecting a Wiegand Reader

GV-AS120 provides one Wiegand input for connection to the Wiegand reader ranging from 26 to 64 bits. Through the Web interface of GV-AS120, you can set the Wiegand reader as the entry or exit reader. To define the reader, see *9.3.2.A Function Setting*.

The table below shows the wire assignments of the Wiegand input on GV-AS120. Please consult the documentation of your Wiegand reader for wiring. You will need to set up a separate power source to power the Wiegand reader.

Wire color	Definition
Green	Wiegand Data 0
White	Wiegand Date 1

### 3.2.2 Connecting Input Devices

GV-AS120 supports 2 types of inputs:

1. Sensor inputs, e.g. door status
2. Button inputs, e.g. door opener

All inputs are **dry contact** and can be configured as normally open (NO) or normally closed (NC) through the GV-AS120 Web interface. The default value is **NO**. To change the input status, see *9.3.2.F In/Out Function*.

The table below shows the wire assignments of input connectors on GV-AS120.

Wire color	Definition
Yellow	Door Sensor IN1
LRed	Button IN2
Brown	IN COM (GND)

### 3.2.3 Connecting Output Devices

GV-AS120 supports 1 type of output: Door outputs, e.g. electronic lock

The table below shows the wire assignments of output connectors on GV-AS120.

Wire color	Definition
Purple	Door COM
Orange	Door NC
Gray	Door NO

Check if your output device meets the following absolute maximum ratings before connecting it to the Door outputs.

<b>Breakdown Voltage</b>	250V AC, 220V DC
<b>Continuous Load Current</b>	1A (30V DC), 0.3A (125V AC)
<p><b>Note:</b> Absolute Maximum Ratings are those values beyond which damage to GV-AS120 circuit board may occur. Continuous operation of GV-AS120 at the absolute rating level may affect GV-AS120's reliability.</p>	

**To connect an output device:**

The example below illustrates the connection of a locking device to GV-AS120. Connect the (+) point on the locking device to the Door COM wire on GV-AS120, connect the two (-) points of the locking device and the external power supply together, and connect the (+) point on the external power supply to the Door NO or Door NC wire on GV-AS120 based on the state of the locking device.

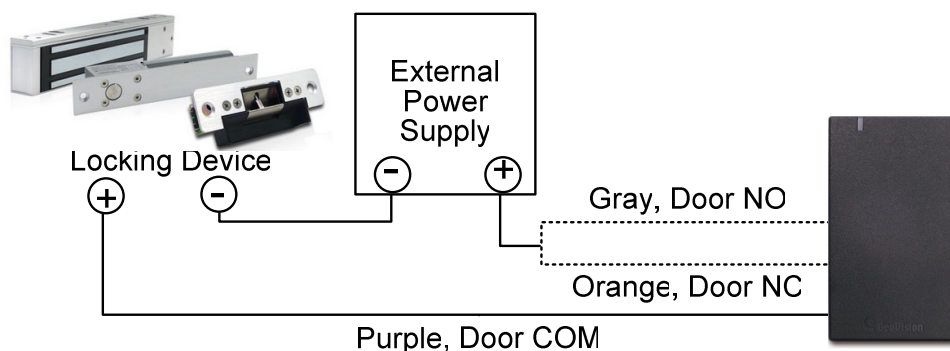

Figure 3-5

### 3.2.4 Connecting to the PC

The computer running GV-ASManager software can be used to monitor the access information and alarm messages from GV-AS120. The communication link between the computer and GV-AS120 can be either through RS-485 or network. For RS-485 connection, a RS-485 to RS-232 converter is required, such as a GV-Hub, GV-COM or GV-NET/ IO Card V3.1. For network connection, an optional GV-ASBox or GV-ASNet is required.

#### 3.2.4.A RS-485 Connection

The figure below illustrates the RS-485 connection to the computer. For this connection, a RS-485 to RS-232 converter between GV-AS120 and the computer is required. You can use GV accessories, such as GV-Hub, GV-COM and GV-NET/IO Card, as the RS-485/RS-232 converter.

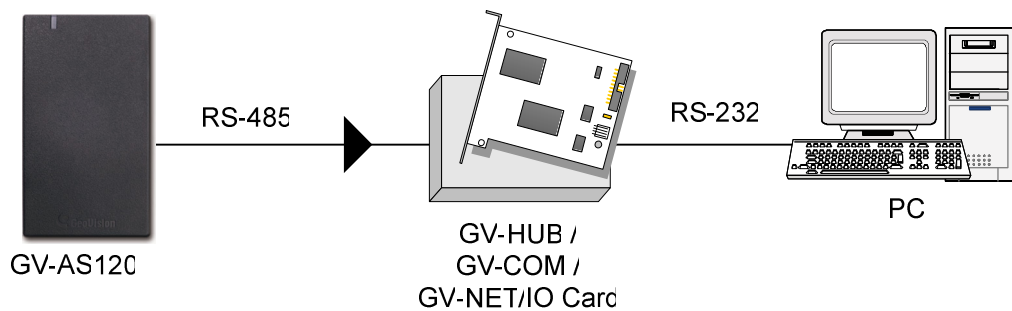

Figure 3-6

The table shows the wire assignments of RS-485 connection on GV-AS120.

Wire color	Definition
Blue	RS485 A+
Light Blue	RS485 A-



### To define ID number, control type and authentication mode

Using the **GV-AS120 Setting AP** in the GV-ASManager folder, you can define the ID number of multiple GV-AS120 connected through RS-485 interface, as well as set the control type and authentication mode.

1. Go to **C:\Access Control\ASManager\** and double-click **GV-AS120 SetupAP V100.exe**. This dialog box appears.

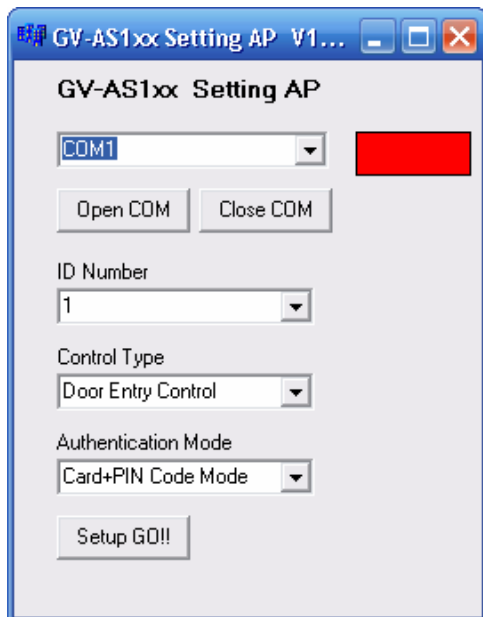
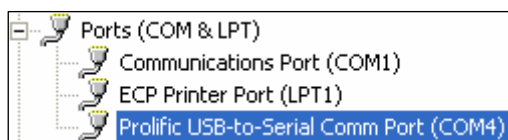

Figure 3-7

2. Select the COM port that is connected to GV-AS120 and click **Open COM**. The red square next to the COM port box should change to blue to indicate the COM port is correct.

---

**Note:** To verify the COM port that is connected to GV-AS120, go to Windows Device Manager. In the Ports (COM & LPT) field, you should see the entry for **Prolific USB-to-Serial Comm Port**. The COM port shown in parenthesis indicates the COM number currently in use.



3. Select an ID number for the GV-AS120.
4. Use the drop-down list to define the **Control Type** and **Authentication Mode**. Refer to *Door / Gate Function* and *Set Authentication Mode* in 2.3.2 *Programming the GV-AS110* for more details on each type of Control Type and Authentication Mode.
5. Click **Setup GO**. The settings are sent to GV-AS120.

### 3.2.4.B Network Connection

The figure below illustrates the network connection to the computer. For this connection, a GV-ASBox or GV-ASNet is required.

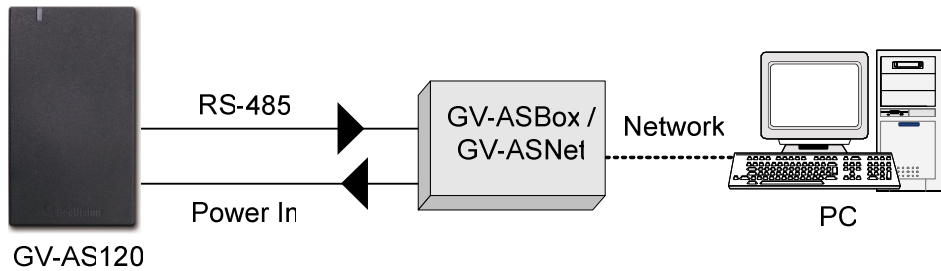

Figure 3-8

Connect two power wires and two RS-485 wires from GV-AS120 to GV-ASBox / GV-ASNet. The table below shows the wire assignments of RS-485 connection on GV-AS120.

Wire color	Definition
Red	12V
Black	GND
Blue	RS485 A+
Light Blue	RS485 A-

See 9.1.4.A Connecting GV-AS100 / 110/ 120 or 9.2.4A Connecting GV-AS100 / 110 / 120 to see how to connect to GV-ASBox or GV-ASNet.

### 3.2.5 Connecting the Power

The supplied AC adaptor can be connected to any power source supplying from 100 to 240V. Connect 12V and GND wires to the supplied power adapter and then connect the power adapter to a power source. The table below shows the pin assignments of the power connectors on GV-AS120.

Wire color	Definition
Red	12V
Black	GND

---

**Note:** Power should only be applied to the unit when all connections are completed and tested.

---

## 3.3 Programming Mode

After powering on GV-AS120, you must create two cards first, an Enroll Card and a Delete Card. The Enroll Card is used for adding new cards and the Delete Card is used for deleting cards. Either card will allow you to program the various configurations on GV-AS120.

---

**Note:** The card complying with ISO 14443A standard for smart card technology can be formatted as an Enroll Card or Delete Card.

---

### To create the Enroll Card and the Delete Card:

1. Power on the unit. The LED flashes blue.
2. Present a card to be the Enroll Card.
3. Present a card to be the Delete Card.
4. The GV-AS120 will automatically load default, and the LED will flash blue and yellow. After 1 to 2 minutes, the LED should be a constant blue light to indicate READY.

### 3.3.1 Adding and Deleting Cards

Using the two cards, you can add new cards to GV-AS120 and delete existing cards on GV-AS120.

---

#### **Note:**

1. GV-ASManager cannot manage the cards enrolled on GV-AS120, since the card data will not be transmitted to GV-ASManager.
  2. The cards added through GV-ASManager cannot be deleted on GV-AS120.
-

### 3.3.1.A Adding a Card

Up to 1,000 cards can be enrolled on GV-AS120 directly without needing additional software. When working with GV-ASManager software, GV-AS120 can support up to 40,000 cards.

1. Present the Enroll Card.
2. Present the card you want to add to the GV-AS120.
3. The GV-AS120 will produce a long beep if the card has been added successfully and three short beeps if the adding procedure has failed.

The default password will be 1234 and the card will automatically be set to a Normal Card. You can change the password and set the card to different card types such as Patrol Card or Two-person A/B Card using GV-ASManager. Refer to the *Adding Cards* section in *GV-ASManager User's Manual* for more details.

---

**Note:** GV-AS120 does not support cards set up as Security Cards.

---

### 3.3.1.B Deleting a Card

1. Present the Delete Card.
2. Present the card you want to delete.
3. The GV-AS120 will produce a long beep if the card has been deleted successfully and three short beeps if the deleting procedure has failed.

## 3.4 LED Status and Beeper

Normally, the LED on GV-AS120 is blue during standby mode and the LED flashes green when a card is granted access or when the operation was successful. A red LED indicates access denied or the operation was unsuccessful. The LED status and beeper under different conditions are listed below.

Condition	LED	Beeper
Card Mode	Constant blue	Silent
Release Mode	Flashes green	Silent
Force Unlock Mode	Flashes green	Silent
Force Lock Mode	Flashes red	Silent
Tamper / Forced Open Alarm	Flashes green and red	Constant beep until alarm cancelled
Held Open Alarm	Unchanged	Constant beep until alarm cancelled
Access Denied Alarm	Flashes red momentarily	Short beep for the number of seconds specified
Access Denied	Flashes red momentarily	Two short beeps
Access Granted	Flashes green momentarily	One short beep
Enroll Card	Flashes green momentarily	Two long beeps
Delete Card	Flashes red momentarily	Two long beeps
Enrolled/Deleted card successfully	Displays green LED momentarily	One long beep
Enroll/Delete card failed	Displays red LED momentarily	Three short beeps
Firmware update	Flashes red, green and blue	Silent
Firmware update failed	Flashes purple	Constant beep
Factory default	Flashes blue	Silent

## 3.5 Web-Based Configurations

Through GV-ASBox or GV-ASNet, GV-AS120 can communicate with GV-ASManager over the network. Using GV-ASBox or GV-ASNet, you can also access the Web interface of GV-AS120.

Refer to *Chapter 10 Optional Devices* to see how to connect a GV-ASBox or GV-ASNet and how to access the Web interface of GV-AS120.

## 3.6 GV-AS120 Specifications

CPU	32-bit RISC microprocessor	
Number of User Cards	1,000 / 40,000 cards (standalone / networked or RS-485 mode)	
Frequency	13.56 MHz for ISO14443A (Mifare DESFire, Mifare Plus and Mifare Classic)	
Event Buffer	65,536 events and log data	
Power	100 ~ 240V AC, 50 ~ 60Hz	
Wiegand Interface	1 Wiegand interface, 26 ~ 64 bit format	
	12V DC Power Supply, 200mA	
Communication Protocol	RS-485	
Digital I/O	Input	2 inputs, dry contact, NO / NC
	Output	1 output
Operating Temperature	-35 ~ 65°C / -31 ~ 149°F	
Operating Humidity	10% ~ 90% RH (non-condensing)	
Dimensions (W X H X D)	65.8 x 115.6 x 20.5 mm / 2.6 x 4.6 x 0.8 in	
Weight	138 g / 0.3 lb	
Certification	IP66, CE, FCC, RoHS	

All specifications are subject to change without notice.

## **4. GV-AS210 Controller**



## 4.1 Introduction

### 4.1.1 Main Features

- One-way control: 4 doors
- Two-way control: 2 doors by Wiegand, 4 doors by Wiegand and RS-485
- Support 4 Wiegand card readers of 26 to 64 bits
- Support 8 GV-Readers / GV-GF Fingerprint Readers through RS485 connection
- Built-in 8 digital inputs and 8 relay outputs
- Suitable for door, parking and elevator access control

### 4.1.2 Packing List

- GV-AS210
- Power Adaptor 12V DC / 3A
- Power Cord
- Battery Cable
- Micro SD Card 2 GB
- GV-ASManager Software DVD

### 4.1.3 GV-AS210 Board Layout

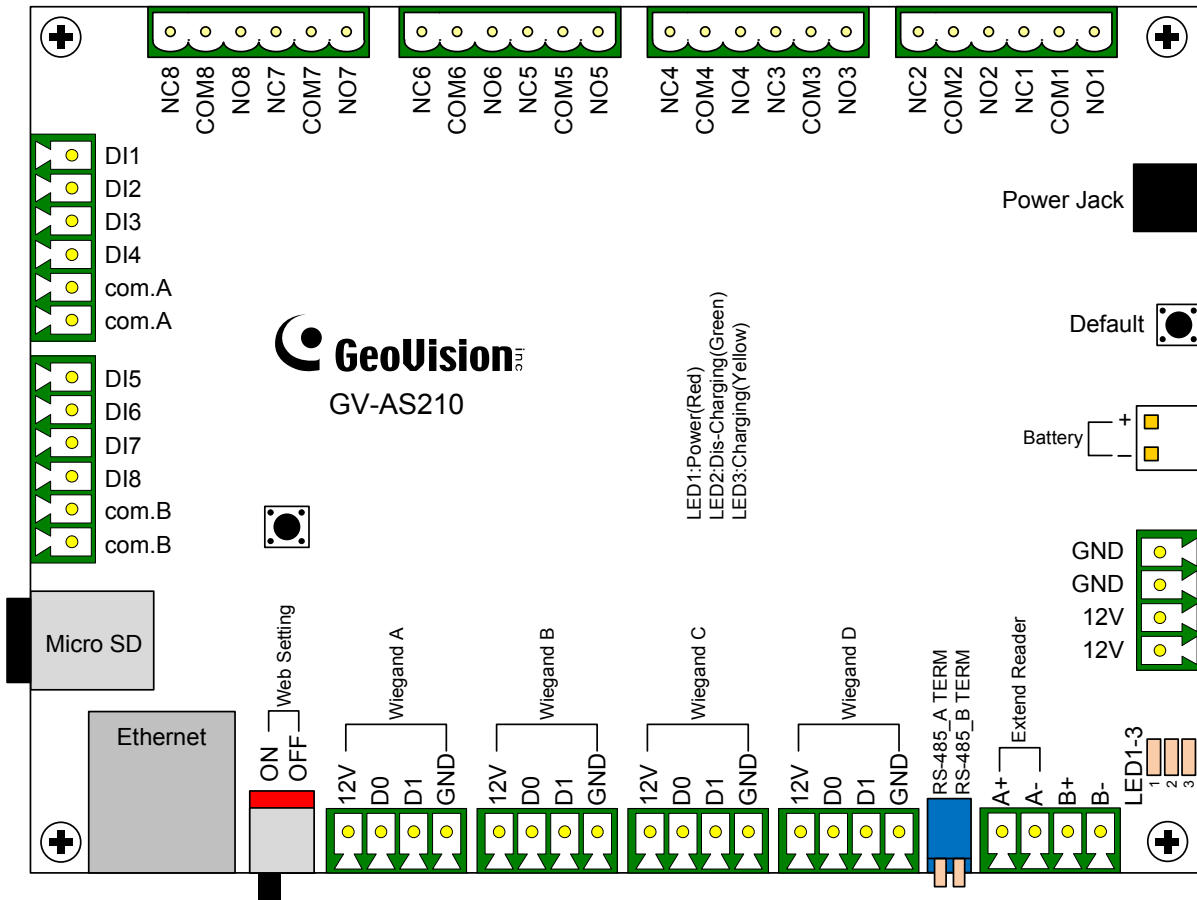

Figure 4-1

## 4.2 Installation

### 4.2.1 Connecting Card Readers

GV-AS210 supports two types of card reader interfaces:

- **Wiegand:** Compatible with any Wiegand card readers of 26 to 64 bits.
- **RS-485:** Only compatible with all **GV-Readers** and **GV-GF Fingerprint Readers**.

#### 4.2.1.A Wiegand Readers

GV-AS210 provides 4 Wiegand inputs (Wiegand A to Wiegand D). Connect up to 4 Wiegand readers ranging from 26 to 64 bits to the Wiegand interfaces. Please consult the documentation of your Wiegand reader for wiring.

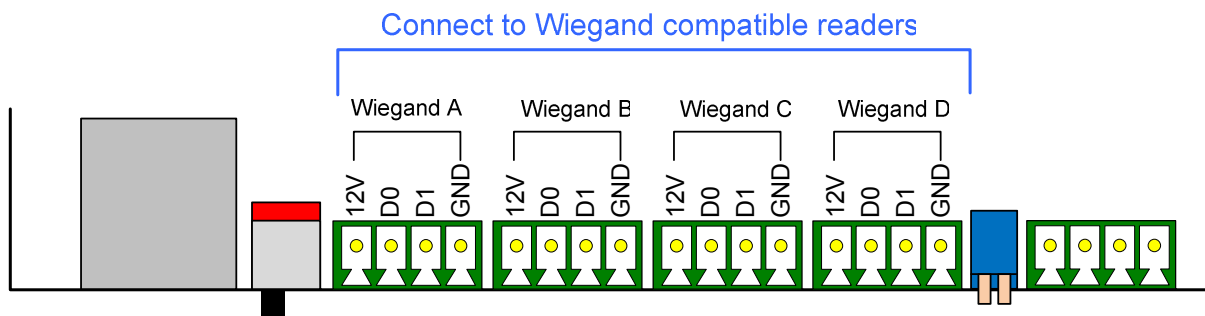

Figure 4-2

### 4.2.1.B RS-485 Readers

For long-distance connection and non-Wiegand card readers, you can establish RS-485 connection with any GV-Readers and GV-GF Fingerprint Readers. Up to **8 readers** can be connected together with a single RS-485 cable to the RS-485 interface on GV-AS210.

When multiple readers are connected together, an extra power supply to each unit is required. Use **12V** power output and **GND** on the power terminal or the Wiegand connectors to power on each unit.

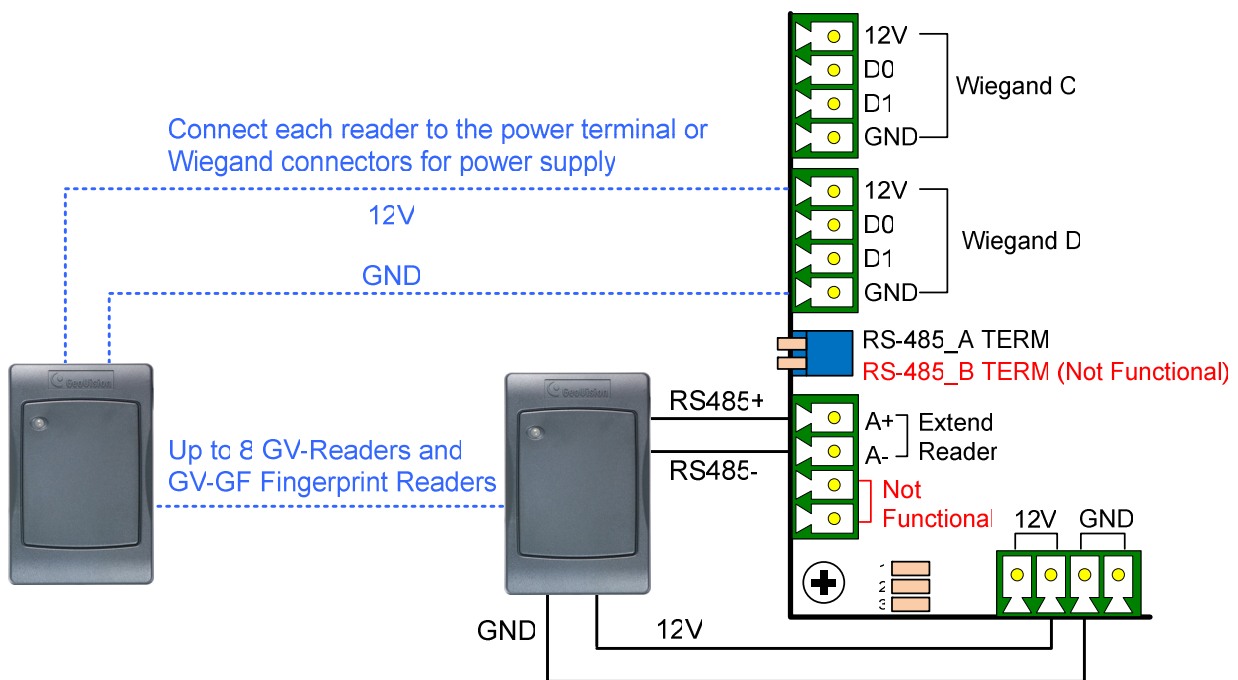

Figure 4-3

#### Note:

1. Each set of 12V power output and GND can provide power for up to 2 readers. The 2 sets on the power terminal can support up to 4 readers. If you wish to connect more readers and the Wiegand interfaces are already occupied, you can connect the readers to external power source.
2. When the RS-485 connection between GV-AS210 and the reader is over 600 meters, turn ON the RS485 A Terminal switch to avoid unstable signals.

### 4.2.2 Connecting Input Devices

Up to 8 input devices can be connected to GV-AS210. Connect the input wires to **DI1~8** and connect GND wires to **com.A** or **com.B**. Multiple GND wires can be connected to the same com.A/B interface.

All inputs are **dry contact** that can be configured as normally open (NO) or normally closed (NC) on the Web interface. To change the input status, refer to *9.2.4 Input Setting*.

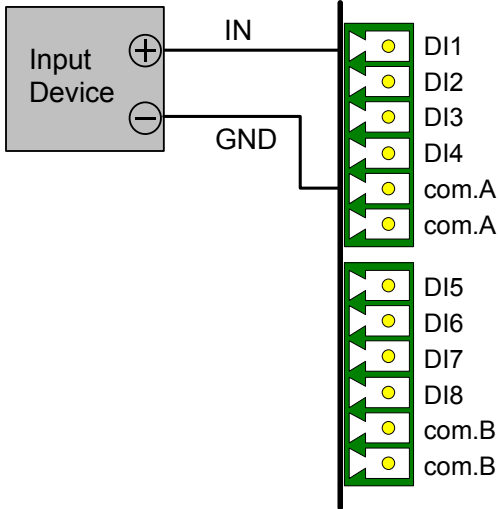

Figure 4-4

---

**Note:** GV-AS210 does not support input devices of wet contact.

---

## 4.2.3 Connecting Output Devices

Up to 8 output devices can be connected to GV-AS210. Check if your output device meets the following absolute maximum ratings before connecting it to outputs 1 ~ 8.

<b>Breakdown Voltage</b>	110V AC ~ 250V AC, 30V DC
<b>Continuous Load Current</b>	3A (AC), 3A (DC)
<p><b>Note:</b> Absolute Maximum Ratings are those values beyond which damage to GV-AS210 circuit board may occur. Continuous operation of GV-AS210 at the absolute rating level may affect GV-AS210 reliability.</p>	

### To connect an output device:

Connect the (+) point on the output device to COM on GV-AS210, connect the two (-) points of the output device and the external power supply together, and connect the (+) point on the external power supply to the NO or NC of GV-AS210 based on the state of the output device.

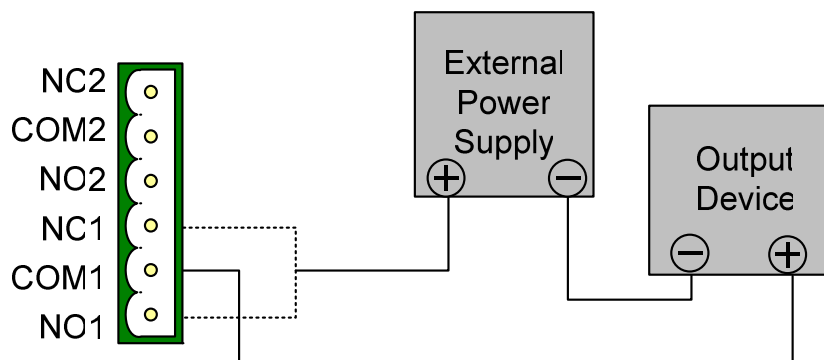

Figure 4-5

---

**Note:** If instead of connecting an external power supply, you want to connect the output devices to the power outputs on the GV-AS210, note that the maximum current of the voltage output is 12V, 0.9A.

---

### 4.2.4 Connecting Backup Battery

You can connect any battery of 12V 12Ah to GV-AS210 to provide backup power when the main power supply fails. When the main power supply is removed and the battery voltage level is above 10.2V, the battery will support normal operation of the GV-AS210.

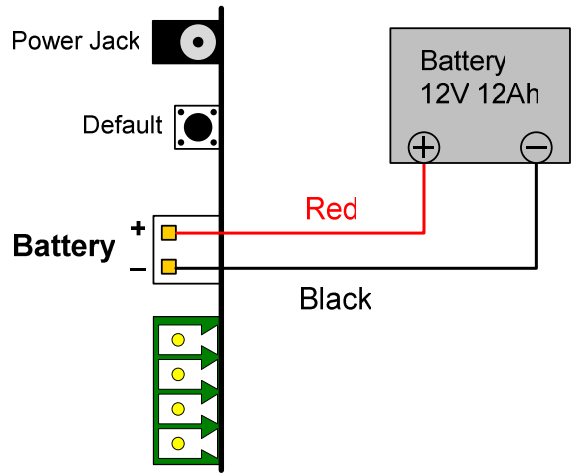

Figure 4-6

### 4.2.5 Connecting the Power

You can connect GV-AS210 to power directly using the supplied 12V DC adaptor. After power is connected, the power LED on GV-AS210 should glow.

---

**Note:** Power should be applied to the unit when all connections are completed and tested.

---

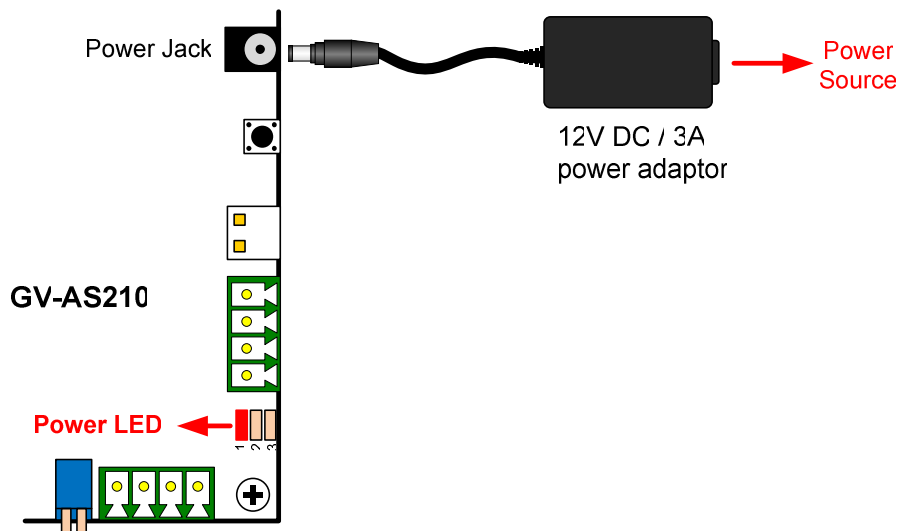

Figure 4-7

## 4.2.6 Connecting the PC

Connecting GV-AS210 to a computer allows you to access its Web interface and connect it to GV-ASManager if the computer is installed with GV-ASManager. The computer running GV-ASManager software can be used to monitor the access information and alarm messages from GV-AS210. If connection with GV-ASManager is interrupted, GV-AS210 stores this information on the supplied micro SD card. The data stored will be sent to GV-ASManager when connection resumes.

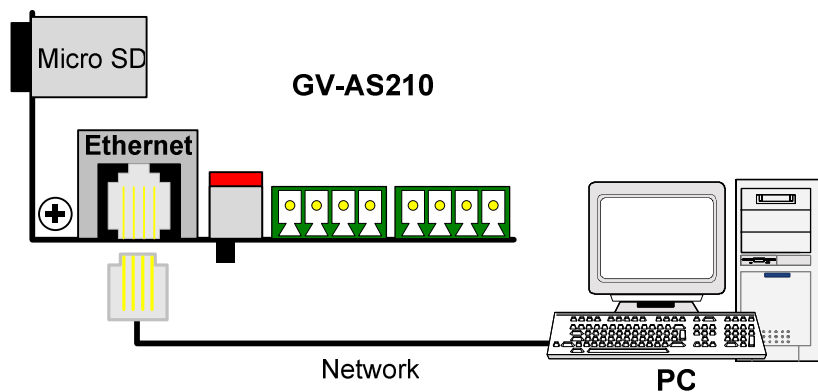

Figure 4-8

---

**Note:** GV-AS210 is only compatible with GV-ASManager V4.0 or later.

---



## 4.3 Other Settings

### 4.3.1 Web Setting Switch

When the **Web Setting** switch is set to the ON position, you can modify **Advanced Settings** and Extended Reader of GV-AS210 through its Web interfaces. When the switch is set to the OFF position, Advanced Settings are not accessible. For details on Advanced Settings, see 8.2 *Advanced Settings*.

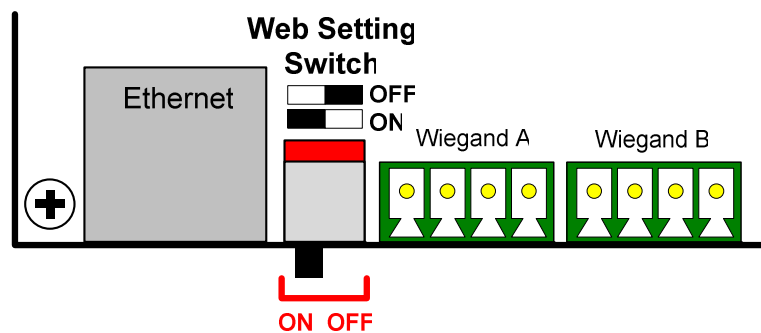

Figure 4-9

### 4.3.2 Resetting the GV-AS210

To reset GV-AS210, press the **Reset** button in the lower left of GV-AS210 circuit board for three seconds.

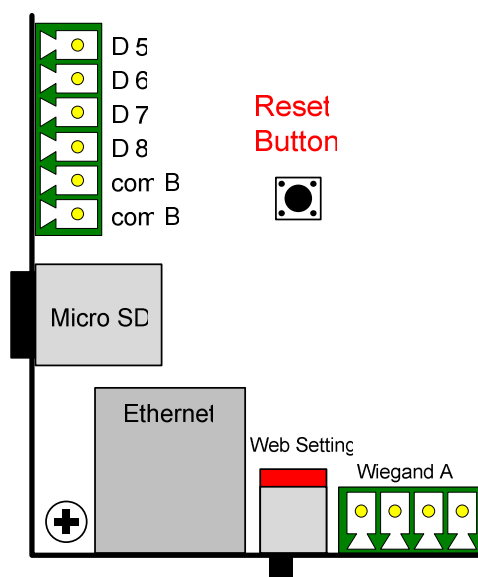

Figure 4-10

### 4.3.3 Restoring Factory Defaults

To restore GV-AS210 to factory default settings, press the **Default** button for 10 seconds.

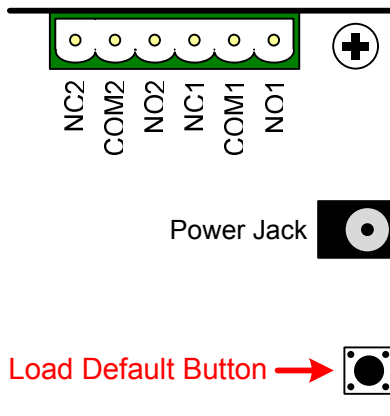

Figure 4-11

## 4.4 The Web Interface

You can install GV-AS210 on a network and configure GV-AS210 through its Web interface.

Refer to *Chapter 8 Installing on a Network* for detailed instructions on setting a fixed or dynamic IP address to access GV-AS210.

Refer to *Chapter 9 The Web Interface* for details on the setup pages of the Web interface. Through the Web interface, you can configure general settings, input/output devices, associated doors/gates and connected readers.

## 4.5 GV-AS210 Specifications

CPU	32-bit ARM7TDMI
Number of User Cards	40,000 cards
Event Buffer	1,000,000 events and log data
Power	100~250V AC, 50~60Hz
RS-485 Interface	1 RS-485 interface only for GV-Readers and GV-GF Fingerprint Readers (max. 8 readers)
Wiegand Interface	4 Wiegand interfaces, 26 ~ 64 bit format
	12V DC power supply, 200mA
Communication	TCP / IP
Input	8 inputs, dry contact, NO/NC
Output	8 relay outputs (30VDC, 3A; 110V AC ~ 250V AC, 3A)
Operating Temperature	0 ~ 65°C / 32 ~ 149°F
Operating Humidity	10% ~ 90% RH (non-condensing)
Dimensions (W X H X D)	210 x 204 x 46.6 mm / 8.27 x 8.03 x 1.83 in (case included)
Weight	810 g / 1.79 lb (case included)
Certification	CE, FCC, RoHS

All specifications are subject to change without notice.

## **5. GV-AS400 Controller**

## 5.1 Introduction

### 5.1.1 Main Features

- 4 doors (one-way and two-way control)
- Support 8 Wiegand card readers of 26 to 64 bits
- Support 8 units of GV-Readers and GV-GF Fingerprint Readers
- Built-in 16 digital inputs and 16 relay outputs
- I/O capability expandable to 64 digital inputs and 64 relay outputs with GV-IO Box connected
- Suitable for door, parking and elevator access control

### 5.1.2 Packing List

- GV-AS400
- GV-AS Power Board
- Power Adaptor 24V DC (for GV-AS Power Board)
- Power Cord
- Adaptor Cable (for connection between GV-AS400 and GV-AS Power Board)



- GV-ASManager Software DVD

### 5.1.3 GV-AS400 Board Layout

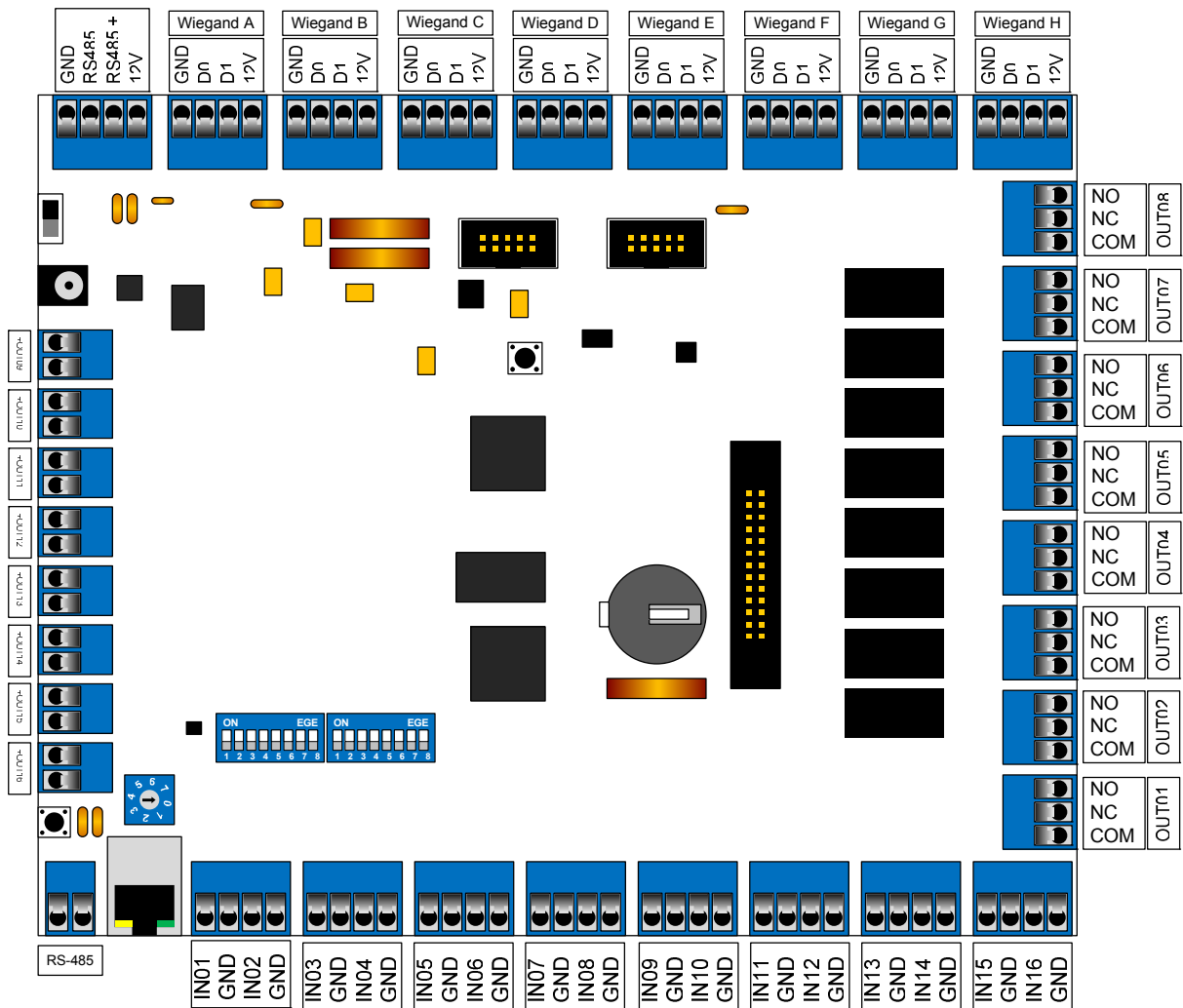
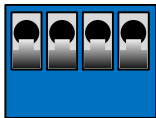

Figure 5-1

## 5.2 Installation

When you wire any devices to GV-AS400 circuit board, please note:

- Carefully remove the blue terminal block and note the block's terminal markings on the circuit board. After wiring the necessary connections to the terminal block, reinsert it onto the circuit board.



### 5.2.1 Connecting Card Readers

GV-AS400 supports two types of card reader interfaces: **Wiegand** and **RS-485**. The Wiegand interface is compatible with any Wiegand card readers of 26 to 64 bits. The RS-485 interface is only compatible with **GV-Readers** and **GV-GF Fingerprint Readers**. The card readers of the two interfaces can be used together to work with GV-AS400.

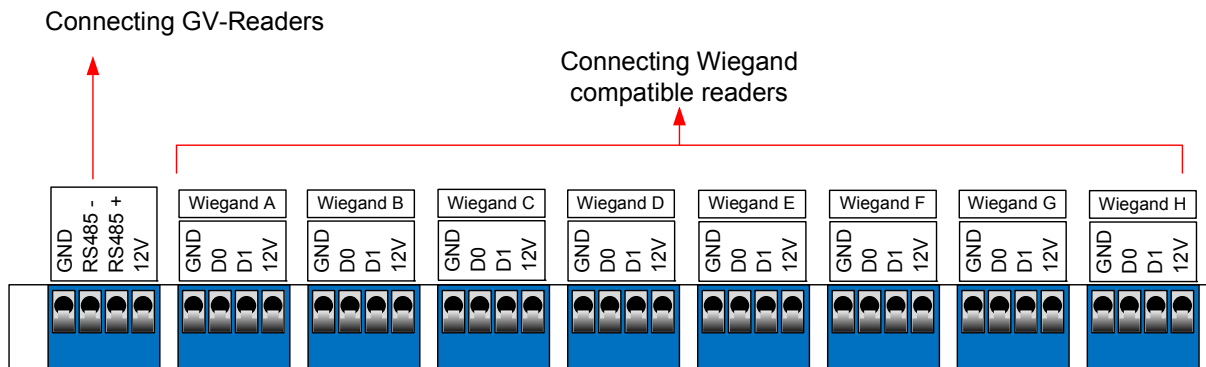

Figure 5-2



### 5.2.1.A Wiegand Readers

GV-AS400 provides 8 Wiegand inputs (Wiegand A to Wiegand H) for connection of Wiegand readers ranging from 26 to 64 bits. The table below shows the pin assignments of Wiegand inputs on GV-AS400. Please consult the documentation of your Wiegand reader for wiring.

Pin	Function
GND	GND of the Power Supply
D0	Wiegand Data 0
D1	Wiegand Data 1
12V	12V Power Supply

If your Wiegand reader is equipped with LED or beeper that can be controlled externally, you can connect the control wires to **outputs 9 ~ 16** on GV-AS400. For the connection, see *5.2.3.B Outputs 9 ~ 16*.

### 5.2.1.B RS-485 Readers

For long-distance connection and non-Wiegand card readers, you can choose the RS-485 connection. Up to **8 units of GV-Readers and GV-GF Fingerprint Readers** can be connected together with a single RS-485 cable to the RS-485 interface on GV-AS400.

When multiple readers are connected together, an extra power supply to each unit is required. Use **12V** power output and **GND** on the Wiegand connectors to power on each unit.

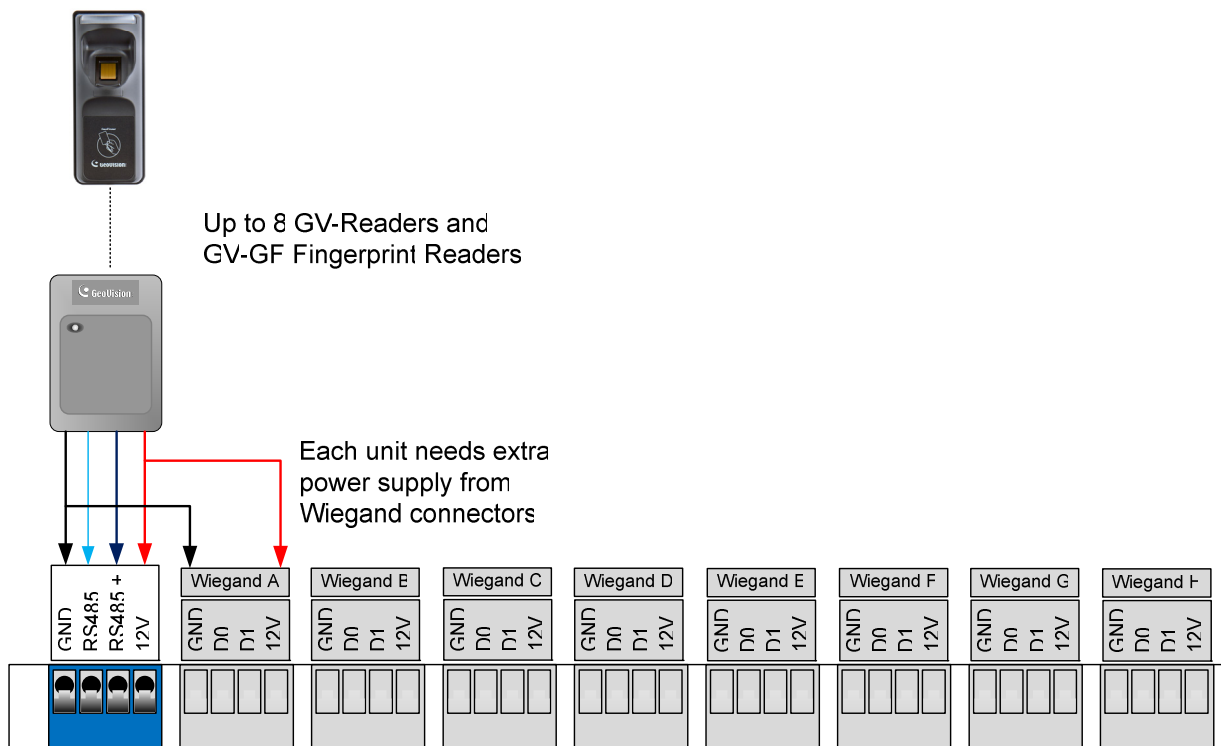

Figure 5-3

#### To connect GV-Readers:

Refer to the following pin assignment for GV-Reader wiring.

Electric Wires on GV-Reader	RS-485 on GV-AS400
Red	12V
Blue	RS-485 +
Light Blue	RS-485 -
Black	GND

## 5.2.2 Connecting Input Devices

GV-AS400 provides up to 16 inputs. All inputs are **dry contact** that can be configured as normally open (NO) or normally closed (NC).

Each input has an LED indicator that turns ON to provide a visual indication that the input device is activated.

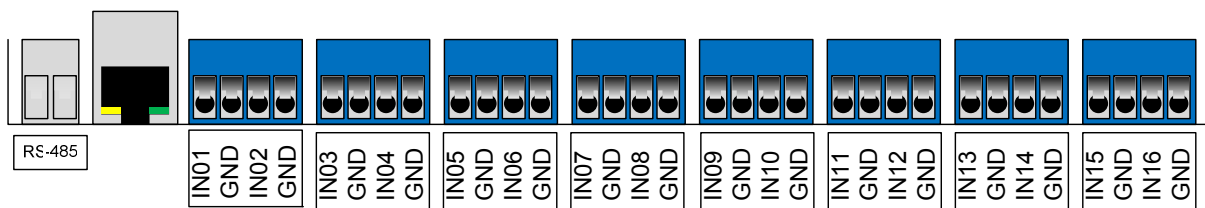

Figure 5-4

Use the switch, as shown below, to change the input state for NO or NC. When the switch is pushed up, the state is NC. When the switch is pushed down, the state is NO. **SW2** is used for inputs 1 to 8 and **SW3** is for inputs 9 to 16.

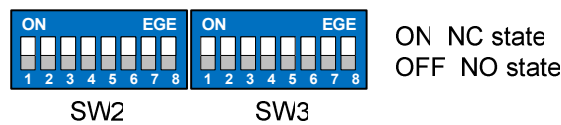

Figure 5-5

Besides having the on-board capability of monitoring 16 inputs, GV-AS400 can be expanded to 64 inputs if 4 units of GV-IO Boxes (16 Ports) are connected. For details, see 5.2.6 *Connecting External I/O Box*.

---

**Note:** GV-AS400 does not support input devices of wet contact.

---

## 5.2.3 Connecting Output Devices

GV-AS400 provides up to 16 outputs. They are divided into two groups, outputs 1 ~ 8 and outputs 9 ~ 16, located at opposite sides of GV-AS400. The two groups of outputs have different absolute maximum ratings. If the current of the output device exceeds 130mA, you will need to connect the device and an external power supply to outputs 1-8. If the current of the output device is under 130mA, you can use outputs 9-16, which only accept the 12V DC internal power supply from GV-AS400 circuit board. In a real application, you may connect door locks to outputs 1-8, and connect LED and Beeper wires of the card reader, powered by GV-AS400, to outputs 9-16.

Each output has an LED indicator that turns ON to provide a visual indication that the output device is activated.

Besides having the on-board capability of monitoring 16 outputs, GV-AS400 can be expanded to 64 outputs if 4 units of GV-IO Boxes (16 Ports) are connected. For details, see *5.2.6 Connecting External I/O Box*.

### 5.2.3.A Outputs 1 ~ 8

Check if your output device meets the following absolute maximum ratings before connecting it to any of outputs 1 ~ 8.

<b>Breakdown Voltage</b>	110V AC ~ 250V AC, 30V DC
<b>Continuous Load Current</b>	3A (AC), 3A (DC)
<p><b>Note:</b> Absolute Maximum Ratings are those values beyond which damage to GV-AS400 circuit board may occur. Continuous operation of GV-AS400 at the absolute rating level may affect GV-AS400 reliability.</p>	

**To connect an output device:**

Connect the (+) point on the output device to COM on GV-AS400, connect the two (-) points of the output device and the external power supply together, and connect the (+) point on the external power supply to the NO or NC of GV-AS400 based on the state of the output device.

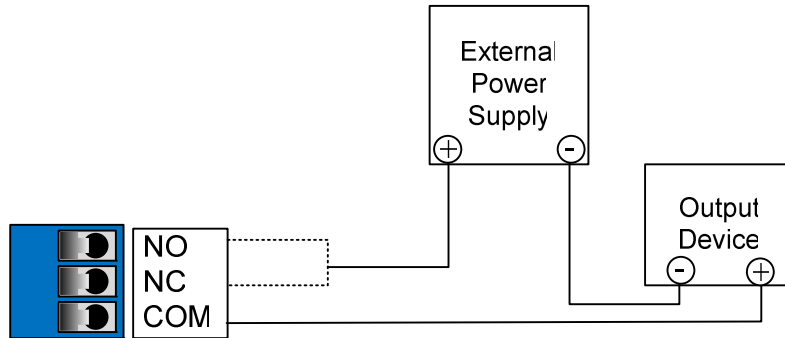

Figure 5-6

**5.2.3.B Outputs 9 ~ 16**

Outputs 9 ~ 16 only accept the power from GV-AS400 circuit board. Check if your output device meets the following absolute maximum ratings before connecting it to any of outputs 9 ~ 16.

<b>Breakdown Voltage</b>	350V DC / AC
<b>Continuous Load Current</b>	130mA
<b>Power Dissipation</b>	500mW
<p><b>Note:</b> Absolute Maximum Ratings are those values beyond which damage to GV-AS400 circuit board may occur. Continuous operation of GV-AS400 at the absolute rating level may affect GV-AS400 reliability.</p>	

**WARNING:** Do not connect any external power supply to outputs 9 ~ 16; otherwise damage to GV-AS400 circuit board may occur.

If your card readers are equipped with LED or beeper that can be controlled externally, connect the control wires to outputs 9 ~ 16. The following figure and table shows how to connect the beeper wire of GV-Reader to GV-AS400.

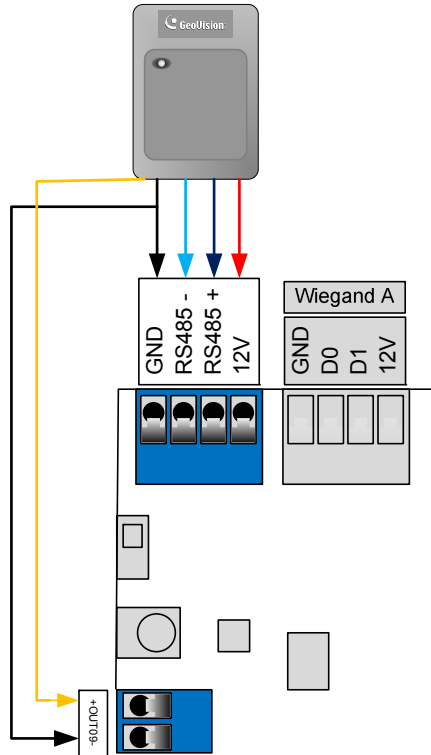

Figure 5-7

Electric Wires on GV-Reader	Output on GV-AS400
Yellow (Beeper)	Output +
Black (GND)	Output -

The **SW1** on GV-Reader must be turned OFF so that the beeper can be controlled by GV-AS400.

## 5.2.4 Connecting the Power

There are two ways to connect GV-AS400 to power: using **GV-AS Power Board** or **directly**. Power should only be applied to the unit when all other connections are completed and tested. After power is connected, the power LED on GV-AS400 should glow.



**Caution:** The supplied 24V DC power adaptor is for GV-AS Power Board. Do not plug the 24V DC power adaptor to the power input of GV-AS400.

### Connect Through GV-AS Power Board:

1. Connect GV-AS400 to GV-AS Power Board using the supplied adaptor cable.
2. Connect the power board to a power source using the supplied power adaptor. The supplied power adaptor can connect to any power source supplying from 100 to 250V.

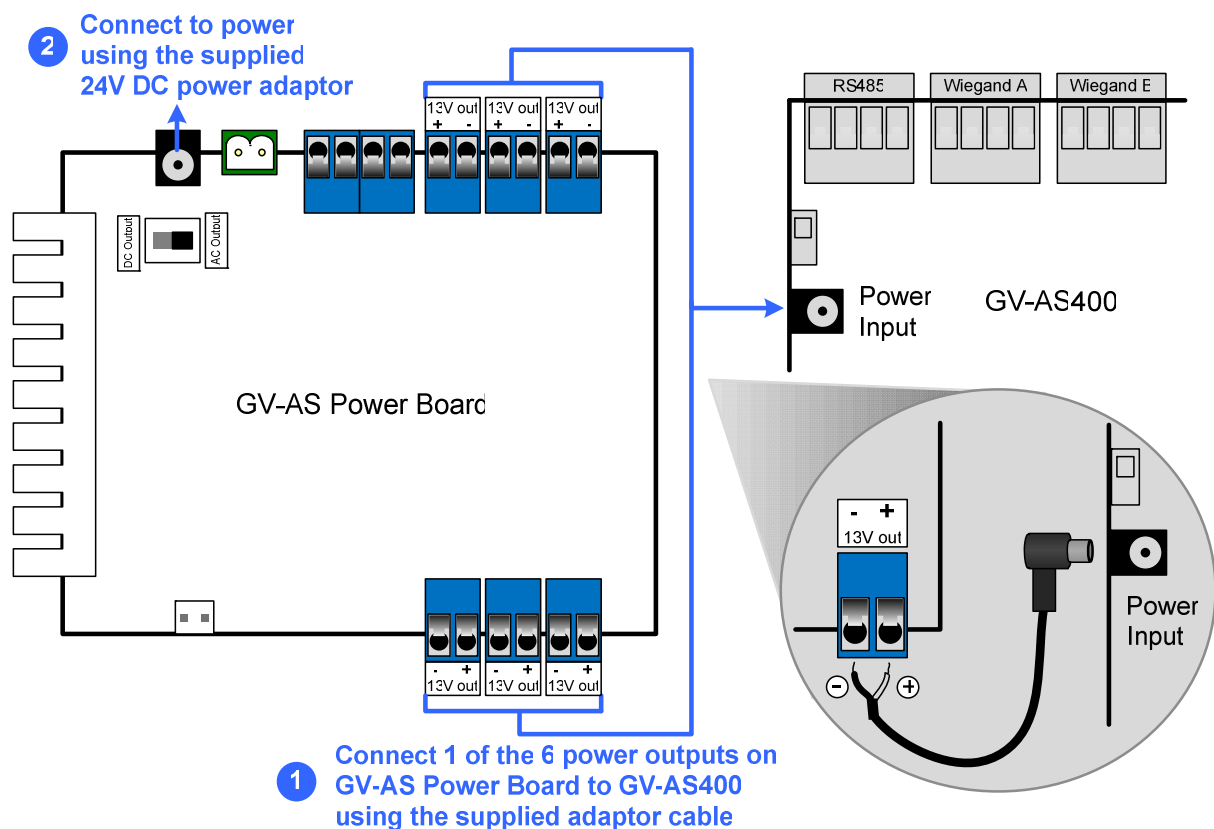

Figure 5-8 Connecting to Power through GV-AS Power Board

### Connect GV-AS400 to Power Directly:

To connect GV-AS400 to a power source directly, you must use a 12V DC adaptor.

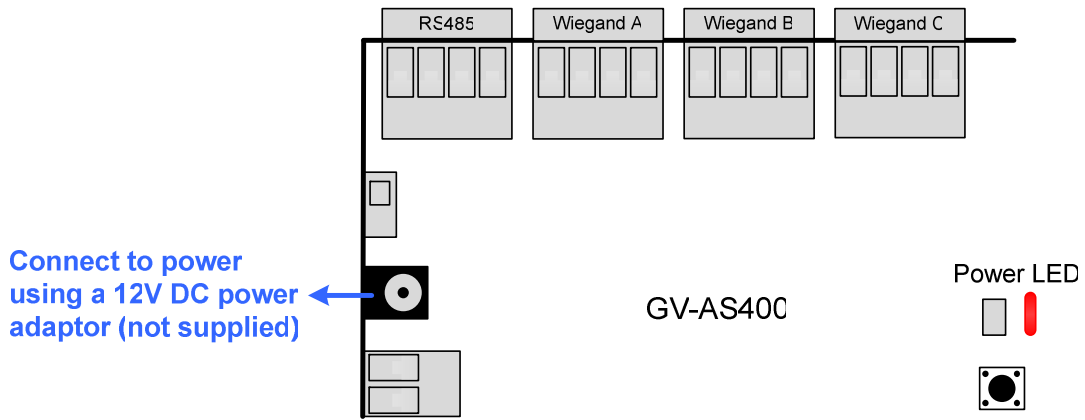

Figure 5-9 Connecting GV-AS400 to Power Directly

---

**Note:** The 12V DC power adaptor is not supplied with the GV-AS400. Do not plug the supplied 24V DC power adaptor to GV-AS400.

---

## 5.2.5 Connecting the PC

Connecting GV-AS400 to a computer allows you to access its Web interface and connect it to GV-ASManager if the computer is installed with GV-ASManager. The computer running GV-ASManager software can be used to monitor the access information and alarm messages from GV-AS400. If connection with GV-ASManager is interrupted, GV-AS400 stores this information on the supplied micro SD card. The data stored will be sent to GV-ASManager when connection resumes.

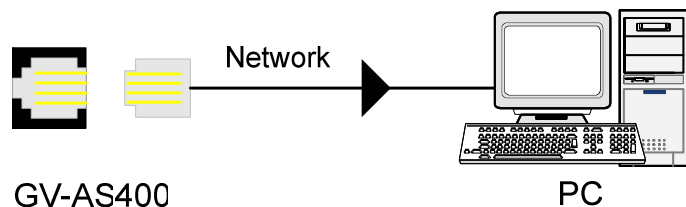

Figure 5-10



## 5.2.6 Connecting the External I/O Box

To enhance the controller's I/O capability, up to 4 units of GV-IO Boxes can be optionally connected to GV-AS400. The choices of the GV-IO Boxes include:

- **GV-IO Box 4 Ports:** 4 ports of inputs and outputs respectively
- **GV-IO Box 8 Ports:** 8 ports of inputs and outputs respectively
- **GV-IO Box 16 Ports:** 16 ports of inputs and outputs respectively

Connect GV-IO Box to the RS-485 connectors as illustrated below. Multiple GV-IO Boxes of different port types can be connected on a single RS-485 cable to work with GV-AS400.

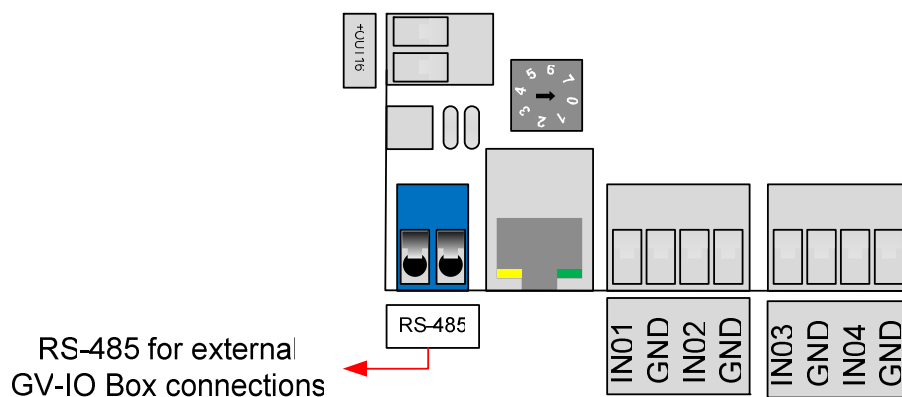
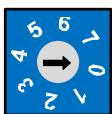

Figure 5-11

The RS-485 cable has the limit in communication distance. As the distance becomes greater, the communication signal may become weak. In this case, decrease the resistance value by using the switch as shown below.



Switch No.	Resistance Value	Switch No.	Resistance Value
0	$\infty$	4	30 $\Omega$
1	120 $\Omega$	5	24 $\Omega$
2	60 $\Omega$	6	20 $\Omega$
3	40 $\Omega$	7	17.14 $\Omega$

## 5.2.7 Fitting the Battery

GV-AS400 includes a 3V lithium battery, providing power to GV-AS400 settings and real-time clock circuitry. When the power in the battery becomes low, the message “Low Battery” will appear on GV-ASKeypad. In this case, please replace the battery. All settings on GV-AS400 will disappear about 10 hours after the battery stops working, and GV-AS400 will be restored to default settings.

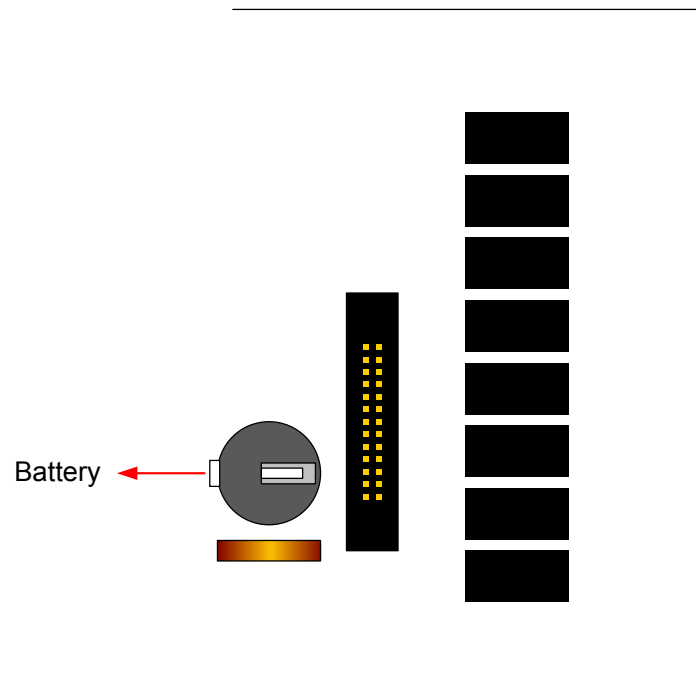

Figure 5-12

---

**Note:**

1. Make sure the plastic insulation film under the battery is removed.
  2. It is recommended to replace the battery annually.
-

## 5.3 Other Settings

### 5.3.1 Web Setting Switch

When the **Web Setting** switch is set to the ON position, you can modify **Advanced Settings** and **Extended Reader** settings of GV-AS400 through its Web interfaces. When the switch is set to the OFF position, Advanced Settings and Extended Reader settings are not accessible. For details on Advanced Settings and Extended Reader settings, see 9.2 *Advanced Settings* and 9.3.1 *Extended Reader*.

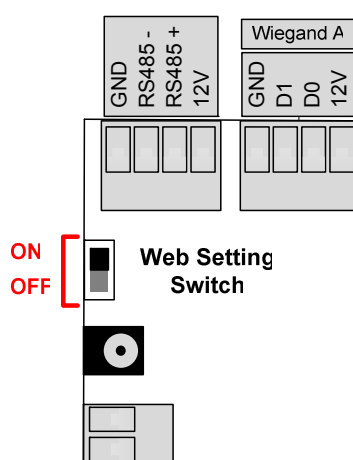

Figure 5-13

### 5.3.2 Resetting the GV-AS400

1. To reset GV-AS400, press the **Reset** button in the upper center of GV-AS400 circuit board for three seconds.
2. To reset the Ethernet module of GV-AS400, press the **EM Reset** button located on the Ethernet module for three seconds.

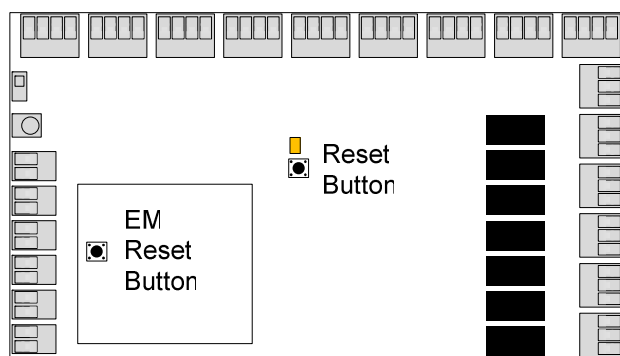

Figure 5-14

### 5.3.3 Restoring Factory Defaults

You can choose to restore only **Basic Settings** or **All Settings** to factory default values. For the contents of Basic Setting, see *8.1 Basic Settings*.

**To restore Basic Settings to factory defaults:**

Press the **Default** button, between the output 16 and RS-485 connectors, for 3 seconds. After this it may take up to 3 minutes to restore Basic Settings of GV-AS400 to default factory values.

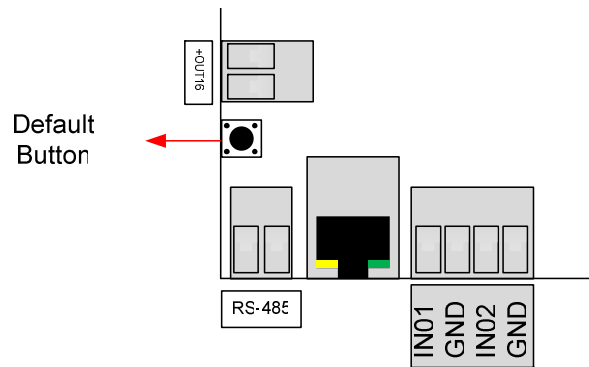

Figure 5-15

**To restore All Settings to factory defaults:**

1. Remove the jumper cap from **JP6** to **JP7**.
2. Press the **Reset** button in the upper center of GV-AS400 circuit board. All input LEDs should light on.
3. Remove the jumper cap from **JP7** back to **JP6**.

After above steps, it may take up to 3 minutes to restore all settings to factory default values. If GV-ASKeypad is connected, the message “Memory Test on Keypad” will appear indicating the default loading is in progress.

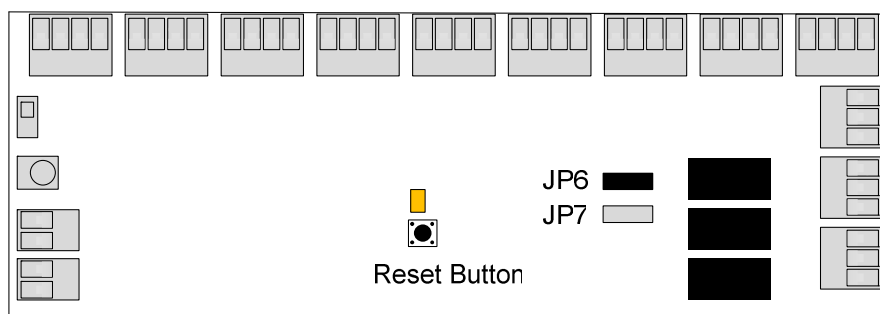

Figure 5-16

## 5.4 The Web Interface

You can install GV-AS400 on a network and configure GV-AS400 through its Web interface.

Refer to *Chapter 8 Installing on a Network* for detailed instructions on setting up a fixed or dynamic IP address to access GV-AS400.

Refer to *Chapter 9 The Web Interface* for details on the setup pages of the Web interface. Through the Web interface, you can configure general settings, input/output devices, associated doors/gates and connected readers.

## 5.5 Optional GV-ASKeypad

GV-ASKeypad is an optional device for an administrator to control and manage GV-AS400. An administrator can carry GV-ASKeypad around to access GV-AS400 installed at different locations.

### Features:

- 2 Lines x 16 English Characters
- 4 x 4 Keys

### 5.5.1 Installation

1. Flip both clips of the 26-pin connector on GV-AS400.
2. Using the supplied 26-pin ribbon cable, connect GV-ASKeypad to GV-AS400.

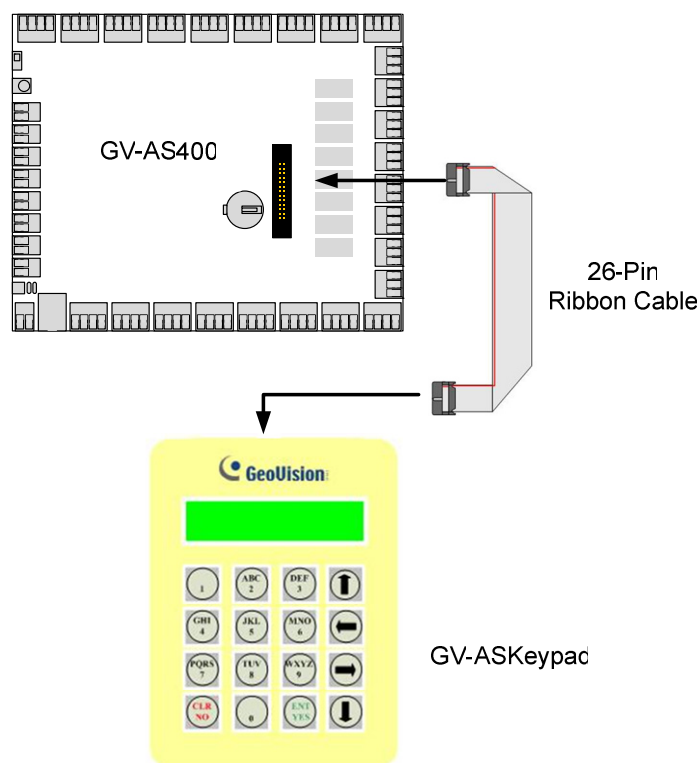

Figure 5-17

---

**Note:** GV-ASKeypad is a hot-swapping product. You can plug or unplug the 26-pin ribbon cable while GV-AS400 is operating.

---

## 5.5.2 Operation

GV-ASKeypad allows you to configure basic settings and view system information. Press the following codes on the keypad to start operating.

Code	Function
* 738	Sets parameters.
* 347	Displays system information
* 737	Restores the Advanced Settings of GV-AS400 to factory defaults.
<b>Note:</b> Press  to display the symbol *	



### 5.5.2.A Setting Parameters

Through GV-ASKeypad, you can program GV-AS400.

---

**IMPORTANT:** Once connecting to GV-AS400, GV-ASManager will load its parameters to GV-AS400. That means some of configurations you have configured may be overwritten by GV-ASManager later.

---

1. Press the code \* **738**.
2. Press the default PIN code **1234**.
3. To set parameters:
  - Use the Up and Down arrow buttons to select options, or change doors for settings.
  - Press  to start setting, or apply settings.
  - Press  to return to the home page.

Option	Function
Set Local Time	Sets the time and specify the time zone of GV-AS400.
Set AS400 ID	Sets the ID of GV-AS400 from 1 to 255.
Set Auth. Mode	<p>Sets an authentication mode for each door. For types of authentication modes, see <i>8.2 Advanced Settings</i>.</p> <p>Press the Right and Left arrow buttons to change modes.</p>

AS400 Function	Sets the function for each door. For types of functions, see 8.2 <i>Advanced Settings</i> . Press the Right and Left arrow buttons to change functions.
Master PIN Change	Changes the PIN code of GV-AS400.
Lock Reset Time	Sets the time (1 to 255 sec.) that a door can remain open, after which the door will automatically be locked.
Set Held Open Time	Sets the time (5 to 9999 sec.) that a door can be held open before an alarm is generated.
Set Alarm Event	Enables or disables the alarm settings for each door. For the types of alarm events, see 8.2 <i>Advanced Settings</i> . Press the Right and Left arrow buttons to select one event type.
Set Fire Action	Locks or unlocks the door/gate when a fire condition occurs.
Set Wiegand Function	Sets the door/gate to be exit or entry. For the same function, see 8.2 <i>Advanced Settings</i> .

### 5.5.2.B Displaying System Information

To display system information, press the code \***347**. To change options or view the status of each door, use the Up and Down arrow buttons.

Option	Function
Door's Auth. Mode	Displays the authentication mode of each door.
Door's Event	Displays what kind of event happened at each door.
Memory's State	Displays the memory usage of GV-AS400. <ul style="list-style-type: none"> <li>■ <b>Capacity:</b> Displays the total number of events that can be recorded on GV-AS400. The maximum number is <b>65536</b>. GV-AS400 will overwrite the oldest events when the limit is reached. When GV-AS400 is connected to GV-ASManager, the event data will be uploaded to the server and the buffer of GV-AS400 will be cleared.</li> <li>■ <b>Stored:</b> Displays the number of events that has been recorded.</li> </ul>
ID & IP Address	Displays the ID and IP address of GV-AS400.
Display Version	Displays the firmware version of GV-AS400.



## 5.6 GV-AS Power Board

GV-AS Power Board is designed for GV-AS400 to provide additional power supply for output devices, such as locking devices and lights. Because GV-AS400 circuit board only supplies 12V power, combining with GV-AS Power Board, GV-AS 400 can directly drive output devices of 24V AC/DC and 10V to 13V DC.

Additionally, GV-AS Power Board supports the battery backup to ensure the normal operations of vital output devices during power failure.

### 5.6.1 Main Features

- 2 power outputs of 24V AC/DC
- 6 power outputs of 10V to 13V DC
- Support for battery backup
- Support for AC and DC power inputs

## 5.6.2 Connecting Output Devices

GV-AS Power Board provides two types of power outputs: **24V AC/DC**, **10V to 13V DC**. The figure below illustrates the locations of these power outputs.

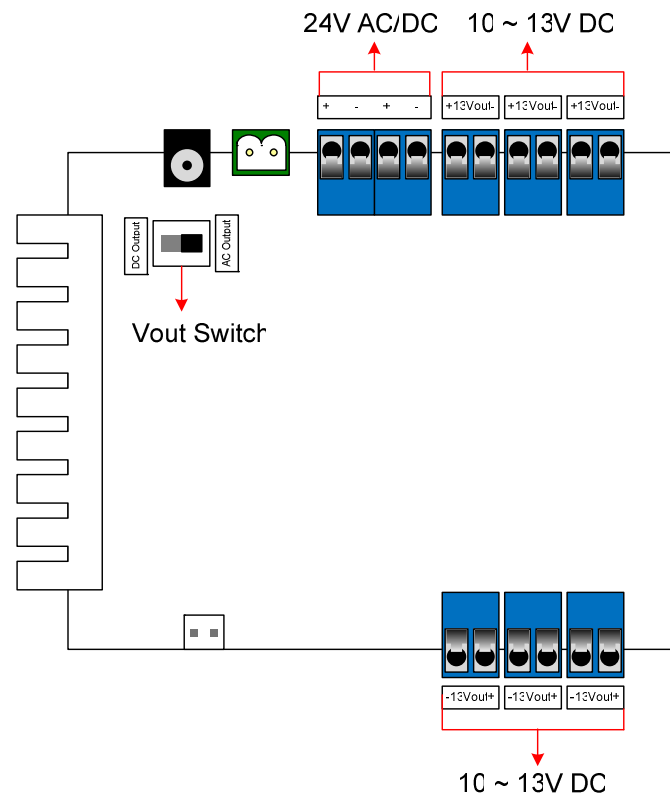

Figure 5-18

- **24V AC/DC:** GV-AS Power Board provides two power outputs of 24V AC/DC. The power current AC or DC is based on the input power source and **Vout Switch** you turned on. If the input power source is AC but the Vout Switch is switched to **DC Output**, the two power outputs of 24V DC will be enlarged to 30V DC.
- **10V to 13V DC:** GV-AS Power Board provides six power outputs of 10V to 13V DC in order to power on the output devices of low current.

Before connecting any output devices, note the following electrical specifications.

Voltage Output	Maximum Current	Absolute Combined Maximum	Absolute Combined Wattage
2 Power Outputs (24V AC/DC)	1.85A (each)	1.85A (24V AC Power In) 2A (24V DC Power In)	63W
6 Power Outputs (10 to 13V DC)	1.85A (each)	2A (24V AC Power In)	
		4A (24V DC Power In)	

### To connect an output device:

Connect the (+) point on the output device to COM on GV-AS400, connect the two (-) points of the output device and GV-AS Power Board together, and connect the (+) power output on GV-AS Power Board to the NO or NC on GV-AS400 based on the state of the output device.

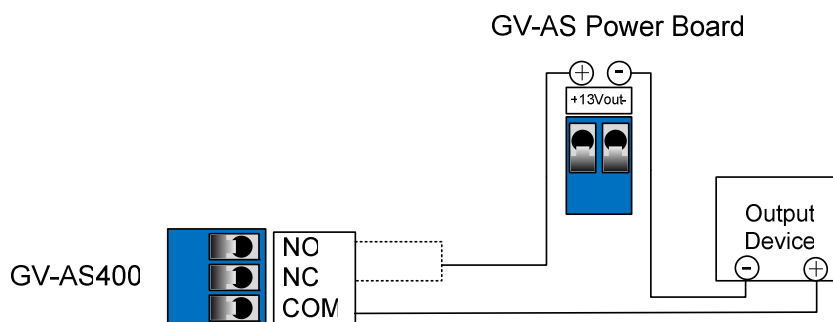

Figure 5-19

## 5.6.3 Connecting the Power

GV-AS Power Board accepts the power input of either 24V AC or 24V DC. You can use the supplied 24V DC power adaptor to connect to a power source. After wiring the power source to the proper connectors on GV-AS Power Board, turn the **Vout Switch** to the power current that is connected.

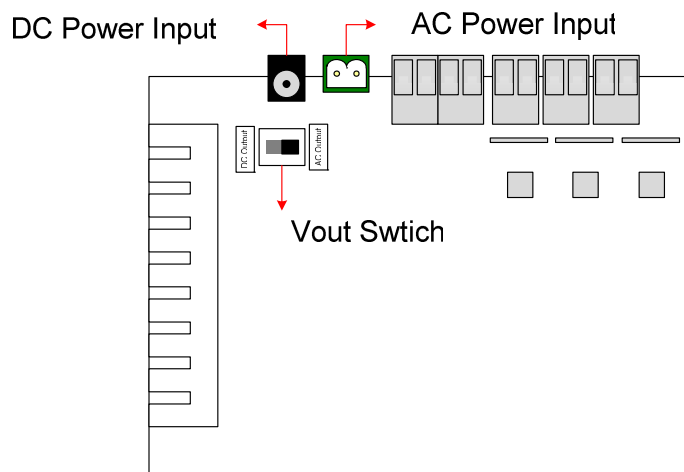

Figure 5-20

### Note:

1. If the power input is 24V AC and the Vout Switch is set to **DC Output**, the voltage of GV-AS Power Board supplies will be enlarged to 30V DC.
2. Power should only be applied to the unit when all connections are completed and tested.

## 5.6.4 Connecting Backup Battery

GV-AS Power Board supports any battery of 12V 12Ah to provide battery backup when the mains supply fails. When the mains supply is removed and the battery voltage level is above 10.2V, the battery will support normal operation.

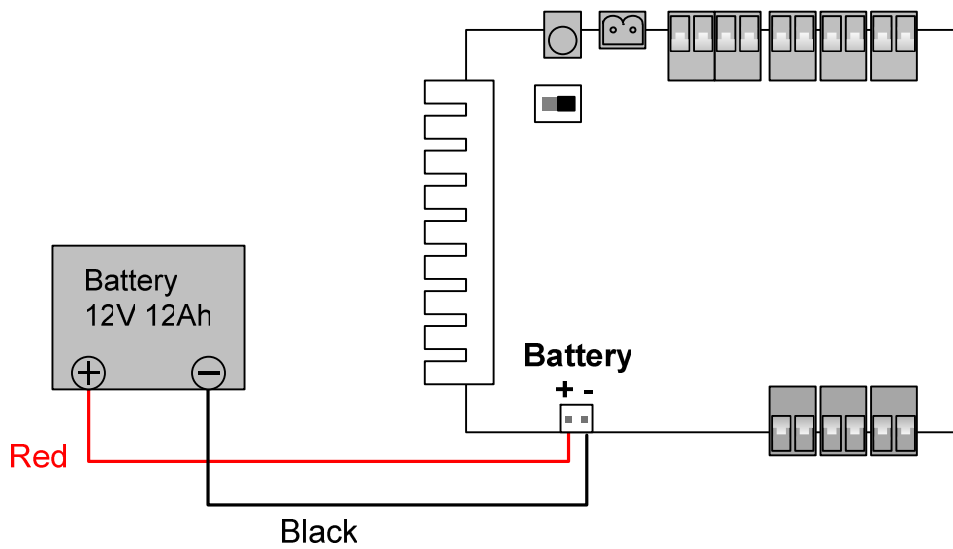

Figure 5-21

---

**Note:** An internal battery verification will cut the battery power if the battery voltage level falls below 10.2V.

---

## 5.7 GV-AS400 Specifications

CPU	32-bit ARM7TDMI & 8-bit RISC microprocessor
Number of User Cards	40,000 cards
Event Buffer	65,536 events and log data
Power	100~250V AC, 50~60Hz
RS-485 Interface	1 RS-485 interface only for GV-Readers and GV-GF Fingerprint Readers (max. 8 readers)
Wiegand Interface	8 Wiegand interfaces, 26 ~ 64 bit format
	12V DC power supply, 200mA
Communication	TCP / IP
Input	16 inputs, dry contact, NO / NC
Output	8 relay outputs (30VDC, 3A; 110V AC ~ 250V AC, 3A) 8 photo relay outputs (30V DC, 130mA)
Operating Temperature	0 ~ 65°C / 32 ~ 149°F
Operating Humidity	10% ~ 90% RH (non-condensing)
Dimensions (W X H X D)	210 x 170 x 30 mm / 8.27 x 6.69 x 1.18 in
Weight	750 g / 1.65 lb
Certification	CE, FCC, RoHS

All specifications are subject to change without notice.

## **6. GV-AS410 / 810 Controller**

## 6.1 Introduction

### 6.1.1 Main Features

- One-way control:  
**GV-AS410:** 4 doors  
**GV-AS810:** 8 doors
- Two-way control:  
**GV-AS410:** 4 doors  
**GV-AS810:** 4 doors by Wiegand, 8 doors by Wiegand / RS-485 / Network
- Support 8 Wiegand card readers of 26 to 64 bits
- Support 8 GV-Readers / GV-GF Fingerprint Readers through RS485 connection
- Built-in 16 digital inputs and 24 relay outputs
- Suitable for door, parking and elevator access control

### 6.1.2 Packing List

- GV-AS410 / 810
- GV-AS410: Power Adaptor 12V DC / 3.5A  
GV-AS810: Power Adaptor 12V DC / 5A
- Power Cord
- Battery Cable
- Micro SD Card 2 GB
- GV-ASManager Software DVD

## 6.1.3 GV-AS410 / 810 Board Layout

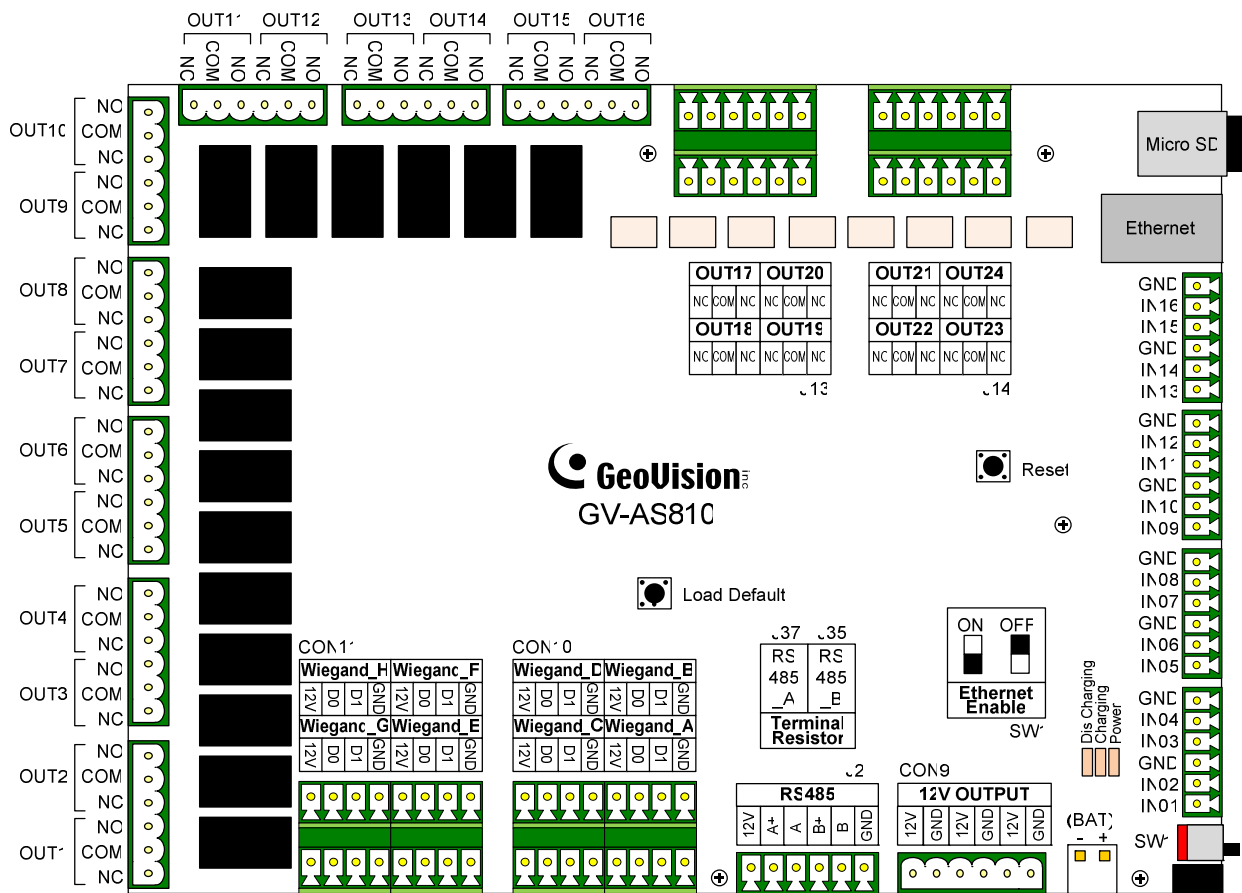

Figure 6-1



## 6.2 Installation

### 6.2.1 Connecting Card Readers

GV-AS410 / 810 supports two types of card reader interfaces:

- **Wiegand:** Compatible with any Wiegand card readers of 26 to 64 bits.
- **RS-485:** Only compatible with all **GV-Readers** and **GV-GF Fingerprint Readers**.

#### 6.2.1.A Wiegand Readers

GV-AS410 / 810 provides 8 Wiegand inputs (Wiegand A to Wiegand H). Connect up to 8 Wiegand readers ranging from 26 to 64 bits to the Wiegand interfaces. Please consult the documentation of your Wiegand reader for wiring.

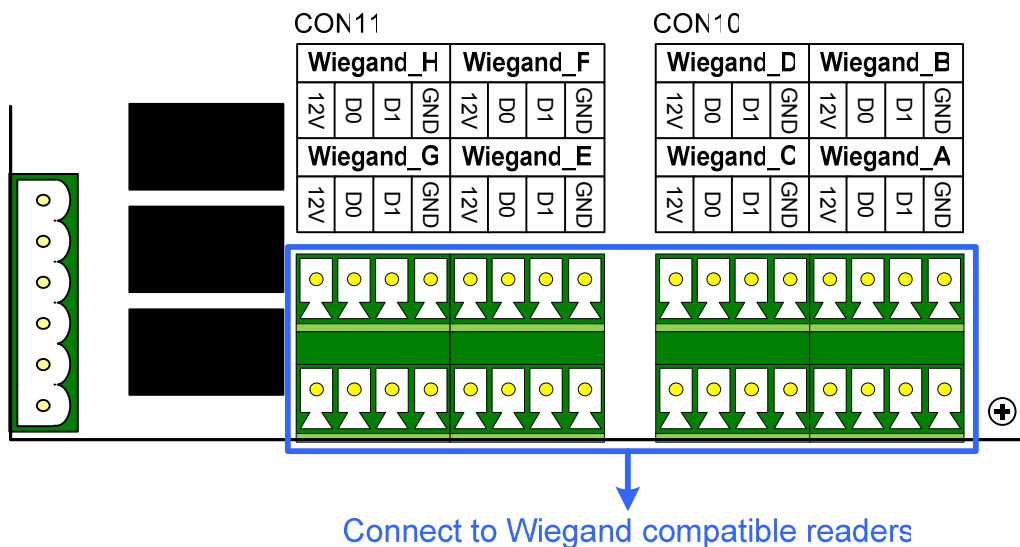

Figure 6-2

---

**Note:** Although 8 Wiegand inputs are available, GV-AS410 only supports control of up to 4 doors.

---

### 6.2.1.B RS-485 Readers

For long-distance connection and non-Wiegand card readers, you can connect RS-485 connection with any GV-Readers and GV-GF Fingerprint Readers. Up to **8 readers** can be connected together with a single RS-485 cable to the RS-485 interface on GV-AS410 / 810.

When multiple readers are connected together, an extra power supply to each unit is required. Use **12V** power output and **GND** on the power terminal or the Wiegand connectors to power on each unit.

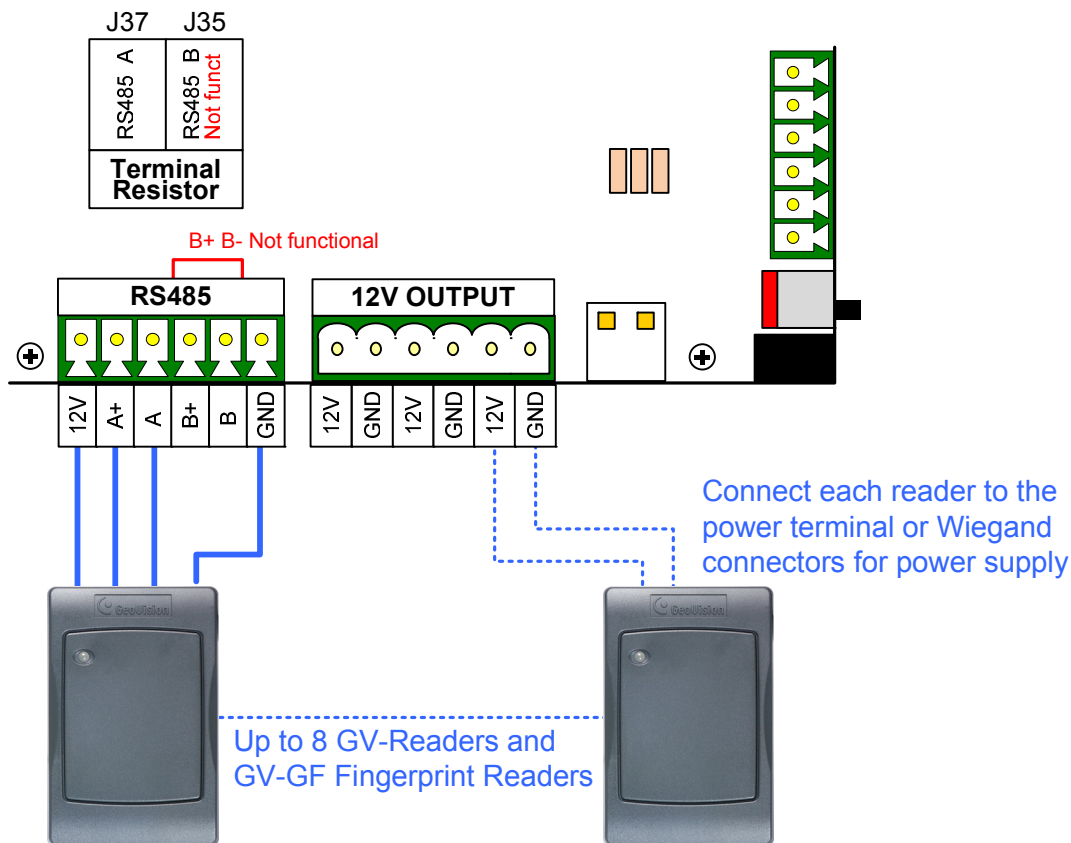

Figure 6-3

#### Note:

1. Each set of 12V power output and GND can provide power for up to 2 readers. The 3 sets on the power terminal can support up to 6 readers. If you wish to connect more readers and the Wiegand interfaces are already occupied, you can connect the readers to external power source.
2. By default, a jumper cap is installed on the RS485\_A Terminal Resistor (J37) to ensure stability when the RS-485 connection between GV-AS410 / 810 and the reader is over 600 meters. RS485\_B Terminal Resistor (J35) is not functional.
3. Although up to 8 RS-485 readers can be connected, GV-AS410 only supports control of up to 4 doors.

## 6.2.2 Connecting Input Devices

Up to 16 input devices can be connected to GV-AS410 / 810. Connect the input wires to **IN1~16** and connect GND wires to **GND**. Multiple GND wires can be connected to the same GND pin.

All inputs are **dry contact** that can be configured as normally open (NO) or normally closed (NC) on the Web interface. To change the input status, refer to *9.2.4 Input Setting*.

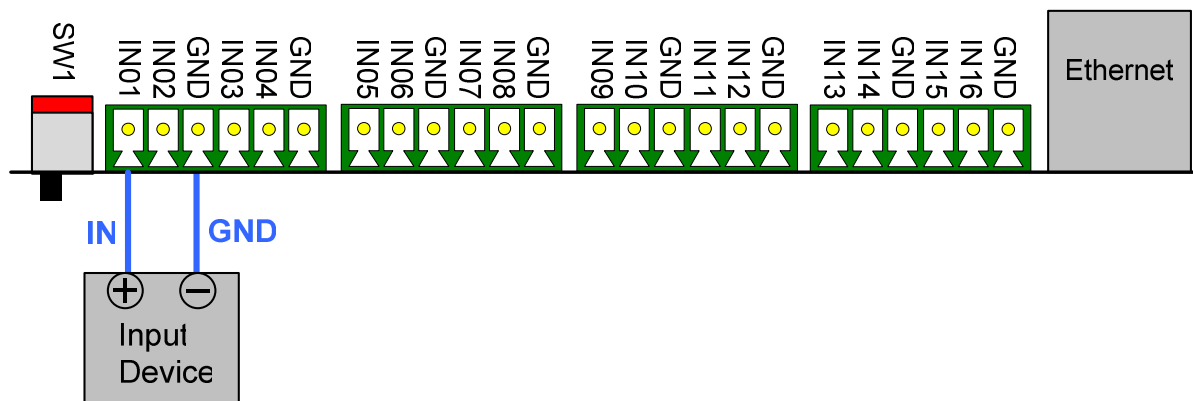

Figure 6-4

---

**Note:** GV-AS410 / 810 does not support input devices of wet contact.

---

## 6.2.3 Connecting Output Devices

Up to 24 output devices can be connected to GV-AS410 / 810. Check if your output device meets the following absolute maximum ratings before connecting it to output terminal block.

Outputs	Outputs 1-16	Outputs 17-24
<b>Breakdown Voltage</b>	110V AC – 250V AC, 30V DC	30V DC
<b>Continuous Load Current</b>	3A (AC), 3A (DC)	1A
<p><b>Note:</b> Absolute Maximum Ratings are those values beyond which damage to GV-AS410 / 810 circuit board may occur. Continuous operation at the absolute rating level may affect GV-AS410 / 810's stability.</p>		

### To connect an output device:

Connect the (+) point on the output device to COM on GV-AS410 / 810, connect the two (-) points of the output device and the external power supply together, and connect the (+) point on the external power supply to the NO or NC of GV-AS410 / 810 based on the state of the output device.

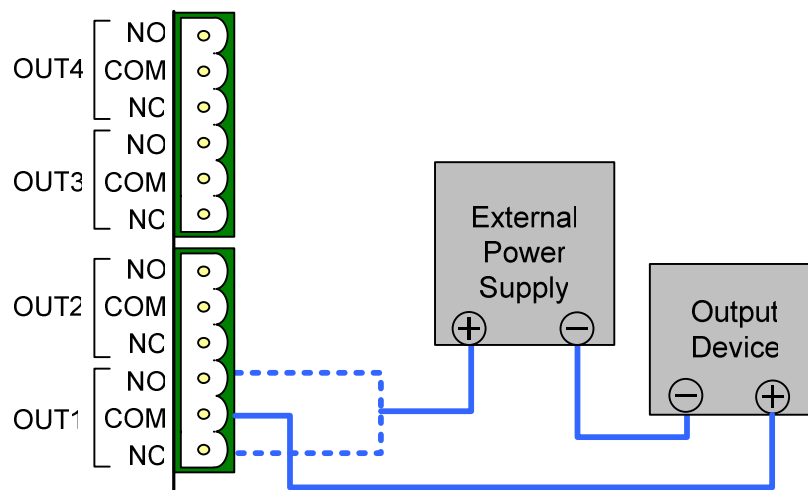

Figure 6-5

---

**Note:** If instead of connecting an external power supply, you want to connect the output devices to the power outputs on the GV-AS410 / 810, note that the maximum current of the voltage output is 12V, 0.9A.

---

## 6.2.4 Connecting Backup Battery

You can connect any battery of 12V 12Ah to GV-AS410 / 810 to provide backup power when the main power supply fails. When the main power supply is removed and the battery voltage level is above 10.2V, the Discharging LED will light and the battery will support normal operation of the GV-AS410 / 810.

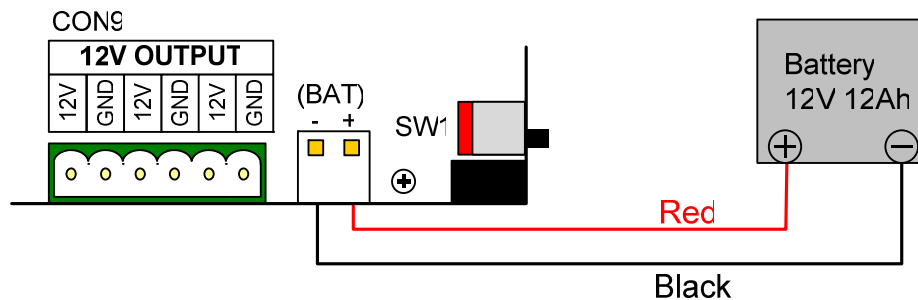

Figure 6-6

## 6.2.5 Connecting the Power

You can connect GV-AS410 / 810 to power directly using the supplied 12V DC adaptor. After power is connected, the power LED on GV-AS410 / 810 should glow.

---

**Note:** Power should only be applied to the unit when all connections are completed and tested.

---

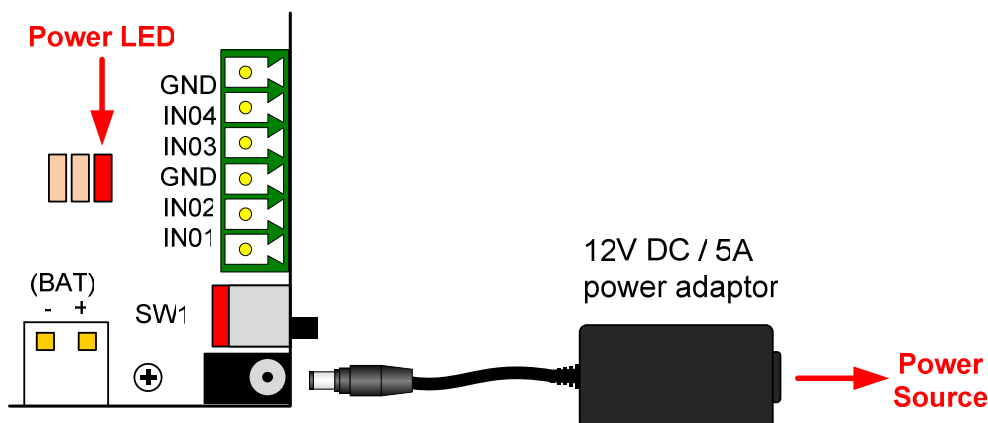

Figure 6-7

## 6.2.6 Connecting the PC

Connecting GV-AS410 / 810 to a computer allows you to access its Web interface and connect it to GV-ASManager if the computer is installed with GV-ASManager. The computer running GV-ASManager software can be used to monitor the access information and alarm messages from GV-AS410 / 810. If connection with GV-ASManager is interrupted, GV-AS410 / 810 stores this information on the supplied micro SD card. The data stored will be sent to GV-ASManager when connection resumes.

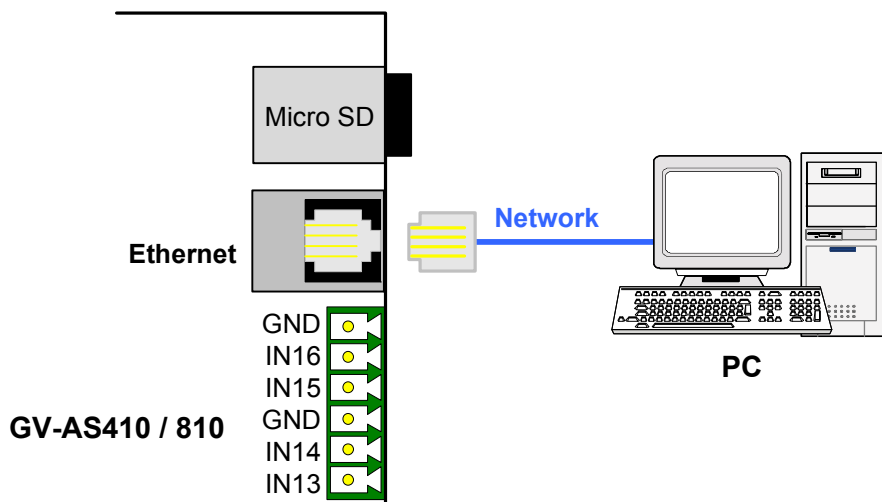

Figure 6-8

---

**Note:** GV-AS410 / 810 is only compatible with GV-ASManager V4.0 or later.

---

## 6.3 Other Settings

### 6.3.1 Web Setting Switch

When the **Web Setting** switch is set to the ON position, you can modify **Advanced Settings** and **Extended Reader** settings of GV-AS410 / 810 through its Web interfaces. When the switch is set to the OFF position, Advanced Settings and Extended Reader settings are not accessible. For details on Advanced Settings and Extended Reader settings, see 8.2 *Advanced Settings* and 9.3.1 *Extended Reader*.

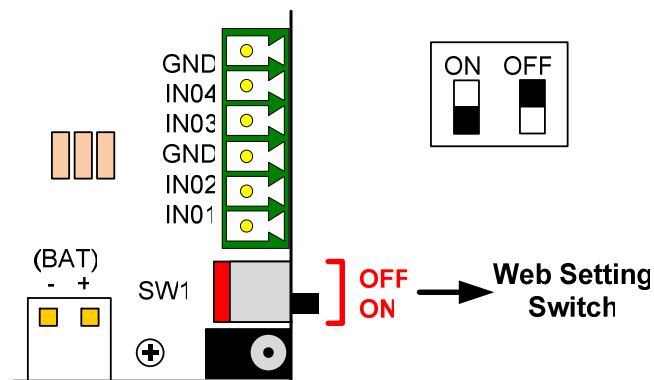

Figure 6-9

### 6.3.2 Resetting the GV-AS410 / 810

To reset GV-AS410 / 810, press the **Reset** button on the right side of GV-AS410 / 810 circuit board for three seconds.

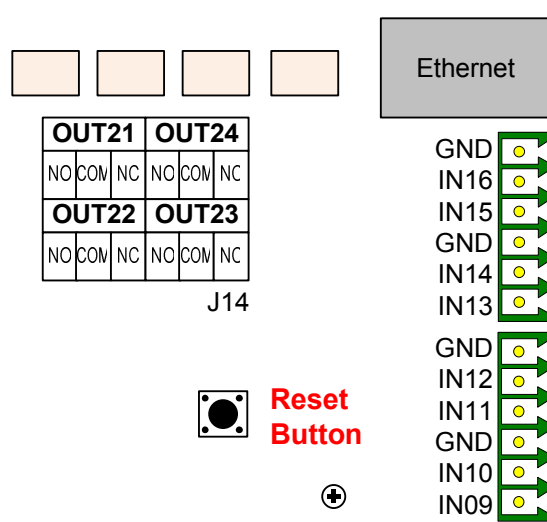

Figure 6-10

### 6.3.3 Restoring Factory Defaults

To restore GV-AS410 / 810 to factory default settings, press the **Default** button for 10 seconds.

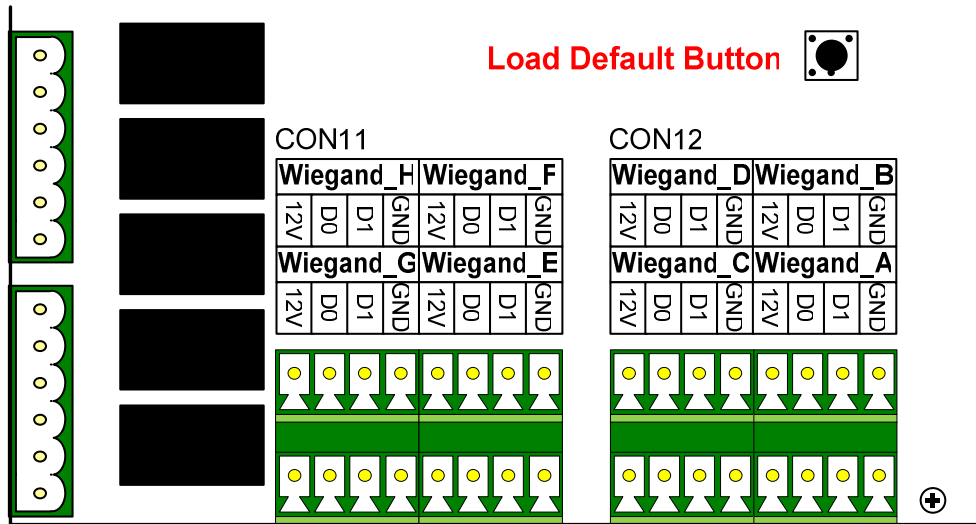

Figure 6-11



## 6.4 The Web Interface

You can install GV-AS410 / 810 on a network and configure GV-AS410 / 810 through its Web interface.

Refer to *Chapter 8 Installing on a Network* for detailed instructions on setting up a fixed or dynamic IP address to access GV-AS410 / 810.

Refer to *Chapter 9 The Web Interface* for details on the setup pages of the Web interface. Through the Web interface, you can configure general settings, input/output devices, associated doors/gates and connected readers.

## 6.5 GV-AS410 / 810 Specifications

CPU	32-bit ARM7TDMI
Number of User Cards	40,000 cards
Event Buffer	1,000,000 events and log data
Power	100~250V AC, 50~60Hz
RS-485 Interface	1 RS-485 interface only for GV-Readers and GV-GF Fingerprint Readers (max. 8 readers)
Wiegand Interface	8 Wiegand interfaces, 26 ~ 64 bit format
	12V DC power supply, 200mA
Communication	TCP/IP
Input	16 inputs, dry contact, NO/NC
Output	24 relay outputs (30VDC, 3A; 110V AC ~ 250V AC, 3A)
Operating Temperature	0 ~ 65°C / 32 ~ 149°F
Operating Humidity	10% ~ 90% RH (non-condensing)
Dimensions (W X H X D)	210 x 187 x 40 mm / 8.27 x 7.36 x 1.57 in
Weight	900 g / 2 lb
Certification	CE, FCC, RoHS

All specifications are subject to change without notice.

## **7. GV-EV48 Controller**

## 7.1 Introduction

GV-EV48 is an elevator controller designed to control access of 1 elevator with a maximum of 48 floors. Up to 2 GV-Readers / GV-GF Fingerprint Readers can be connected to GV-EV48 using RS-485 connection and network connection. GV-EV48 can recognize identification cards and grant access to the authorized floors only.

### 7.1.1 Main Features

- Grant access to specific elevator floors using access cards, card's PIN code or fingerprints
- **GV-EV48 – 24 Floors:** Built-in 24 relay outputs to support up to 24 elevator floors
- **GV-EV48 – 48 Floors:** Built-in 48 relay outputs to support up to 48 elevator floors
- Support up to 2 GV-Readers / GV-GF Fingerprint Readers through network connection and RS-485 connection

### 7.1.2 Packing List

- GV-EV48 – 24 Floors / 48 Floors
- Power Adaptor 12V DC / 3A
- Power Cord
- Battery Cable
- Micro SD Card 2 GB
- GV-ASManager Software DVD

### 7.1.3 GV-EV48 Board Layout

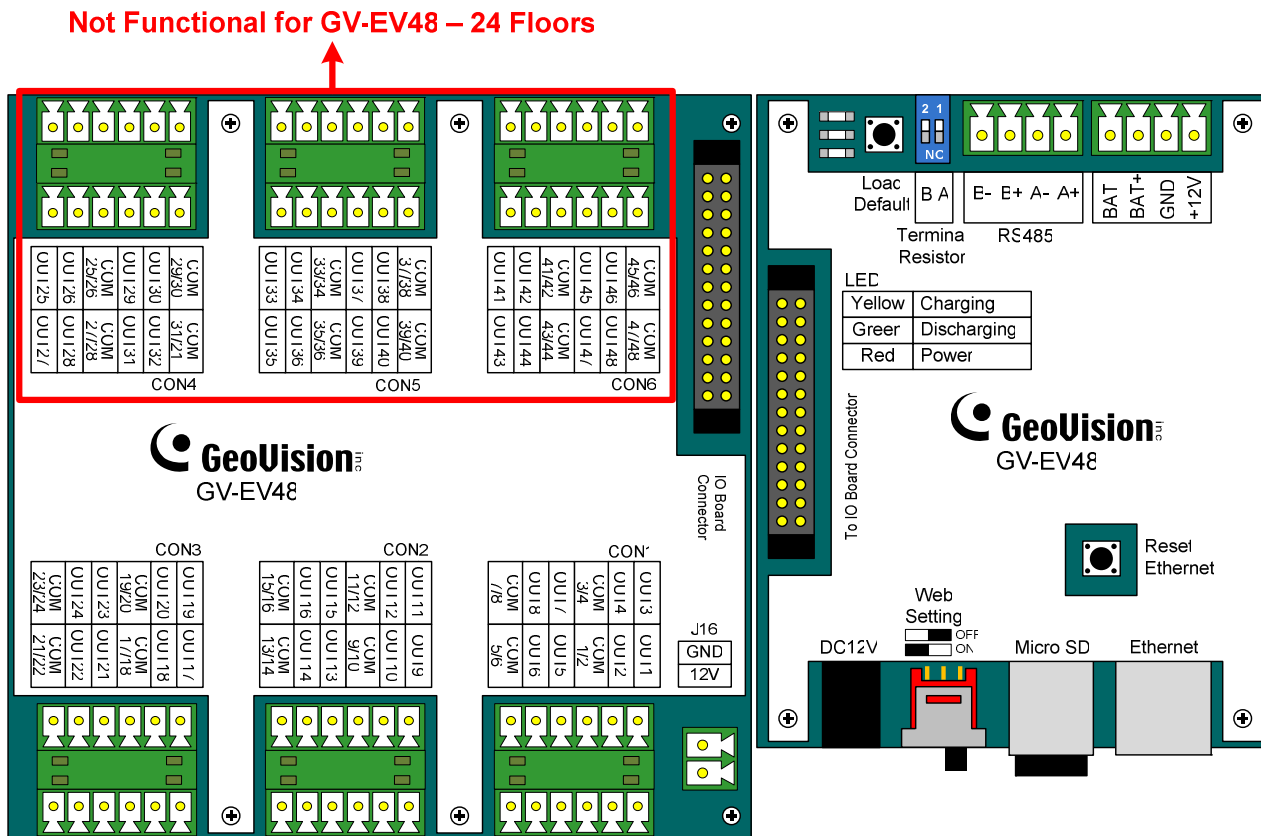

Figure 7-1

## 7.2 Installation

### 7.2.1 Connecting RS-485 Card Readers

With a single RS-485 cable, you can connect up to 2 GV-Readers and / or GV-GF Fingerprint Readers to the RS-485 interface on GV-EV48.

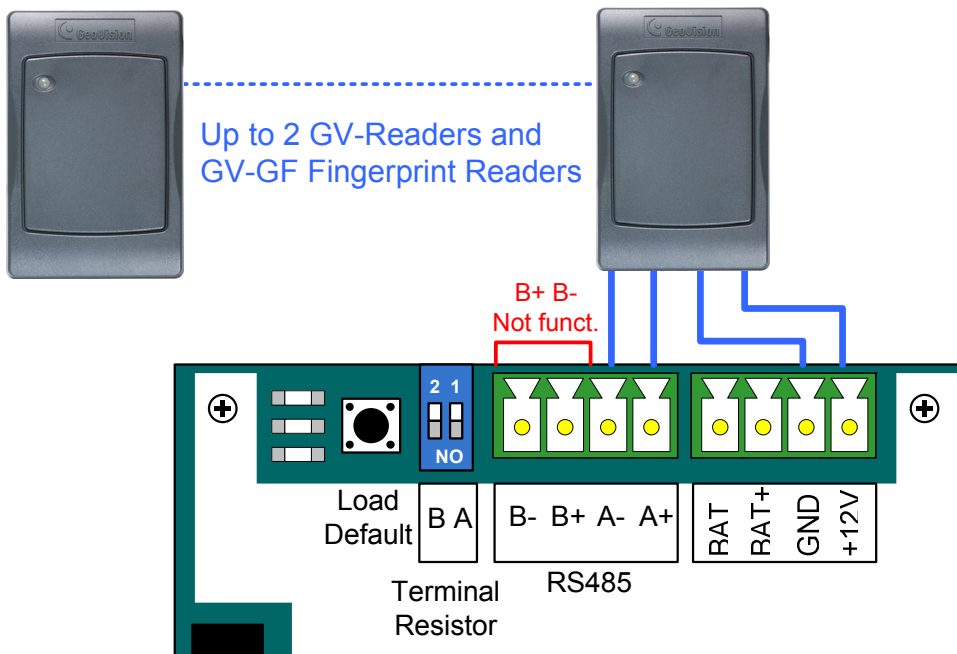

Figure 7-2

To connect to GV-CR420 or GV-GF1921 / 1922 through network connection, refer to 9.3.1 *Extended Reader* for details.

---

**Note:** When the RS-485 connection between GV-EV48 and the reader is over 600 meters, turn ON the RS485 A Terminal switch to avoid unstable signals. RS485\_B Terminal Resistor is not functional.

---

## 7.2.2 Connecting Output Relay

Up to 24 output relays can be connected to the GV-EV48-24 Floors to control up to 24 elevator floors. Up to 48 output relays can be connected to the GV-EV48-48 Floors to control up to 48 elevator floors. Each output relay is set to control access to a corresponding floor in the elevator.

### To connect output relay:

Connect the output relay on the GV-EV48 to the corresponding floor on the elevator control panel. Next, connect the COM on the GV-EV48 to the COM on the elevator control panel.

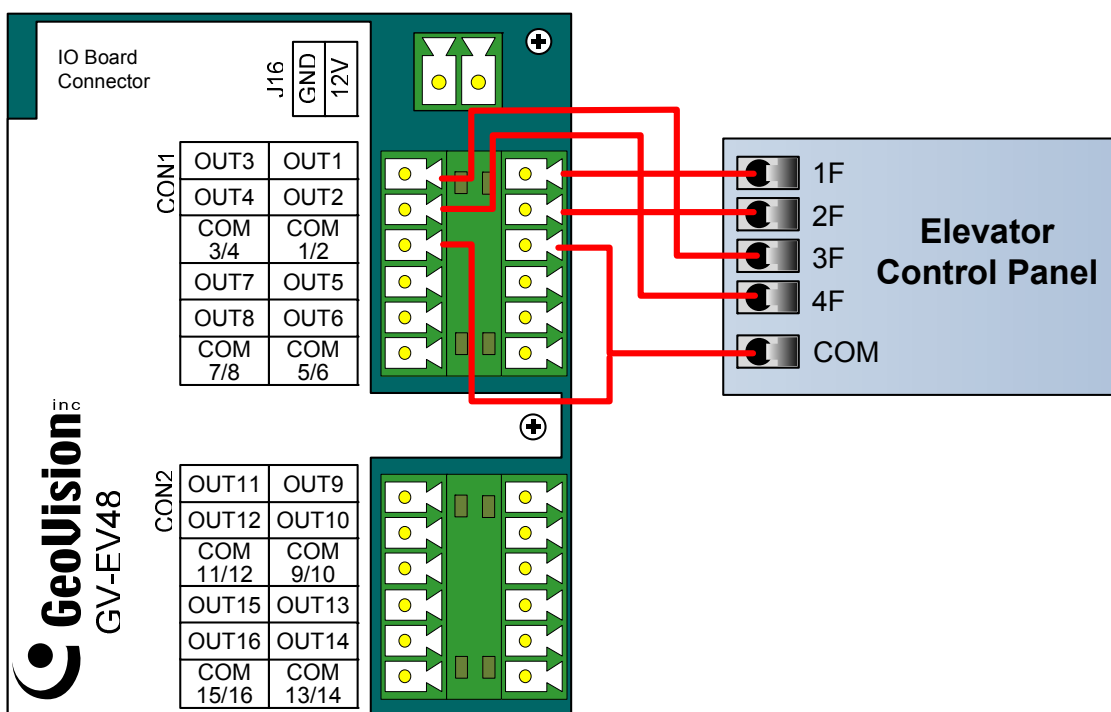

Figure 7-3

### 7.2.3 Connecting Backup Battery

Using the supplied battery cable, you can connect any battery of 12V 12Ah to GV-EV48 to provide backup power when the main power supply fails. When the main power supply is removed and the battery voltage level is above 10.2V, the Discharging LED will light and the battery will support normal operation of the GV-EV48.

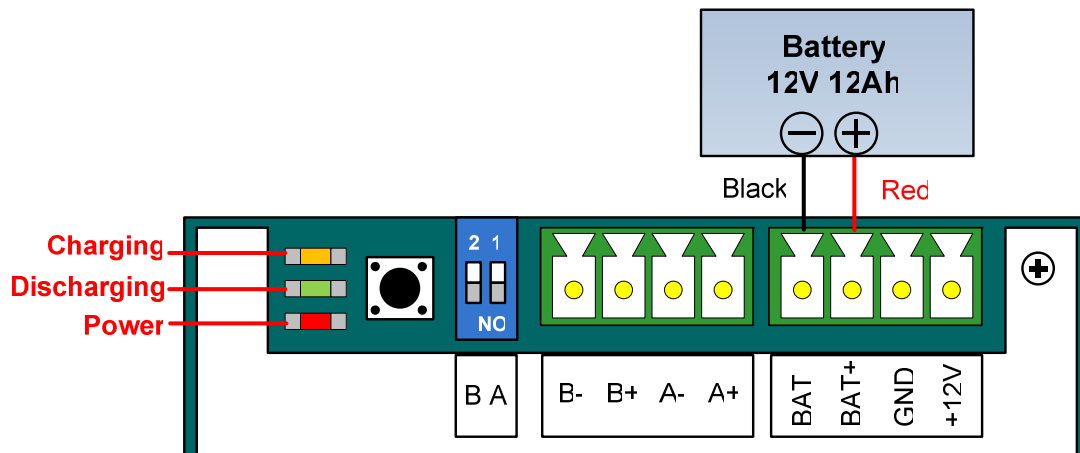

Figure 7-4

### 7.2.4 Connecting the Power

You can connect GV-EV48 to power directly using the supplied 12V DC adaptor. After power is connected, the power LED on GV-EV48 should glow.

**Note:** Power should only be applied to the unit when all connections are completed and tested.

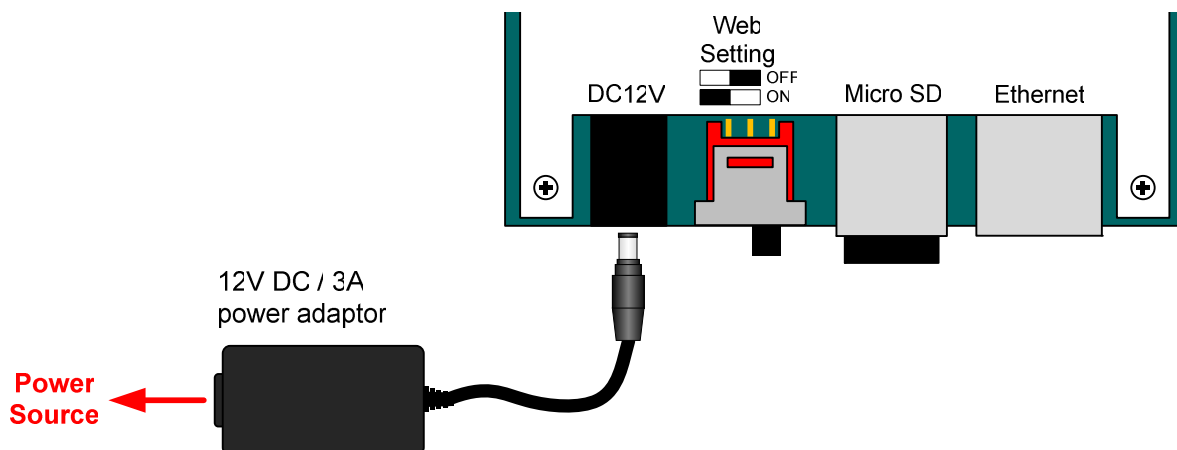

Figure 7-5



## 7.2.5 Connecting the PC

Connecting GV-EV48 to a computer allows you to access its Web interface and connects it to GV-ASManager if the computer is installed with GV-ASManager. The computer running GV-ASManager software can be used to monitor access information from GV-EV48. If connection with GV-ASManager is interrupted, GV-EV48 stores this information on the supplied micro SD card. The data stored will be sent to GV-ASManager when connection resumes.

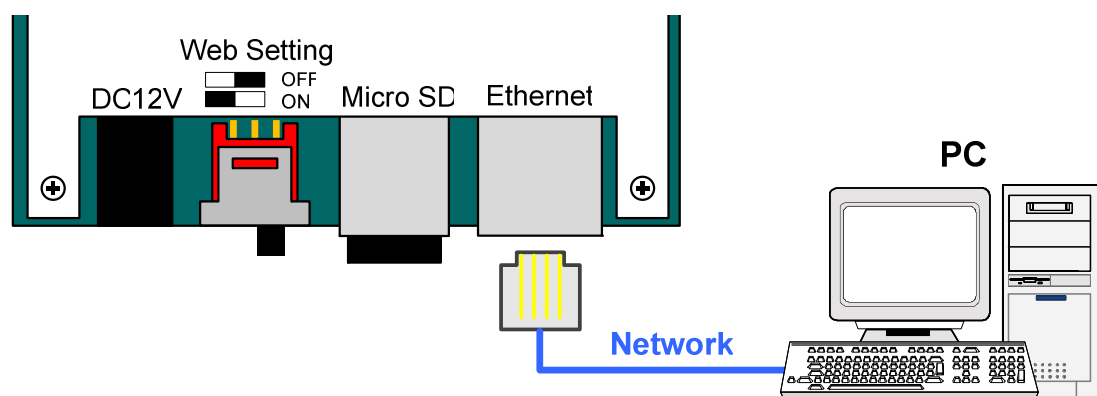

Figure 7-6

---

**Note:** GV-EV48 is only compatible with GV-ASManager V4.1 or later.

---

## 7.3 Other Settings

### 7.3.1 Web Setting Switch

When the **Web Setting** switch is set to the ON position, you can modify **Advanced Settings** and **Extended Reader** settings of GV-EV48 through its Web interfaces. When the switch is set to the OFF position, Advanced Settings and Extended Reader settings are not accessible. For details on Advanced Settings and Extended Reader settings, see 9.2 *Advanced Settings* and 9.3.1 *Extended Reader*.

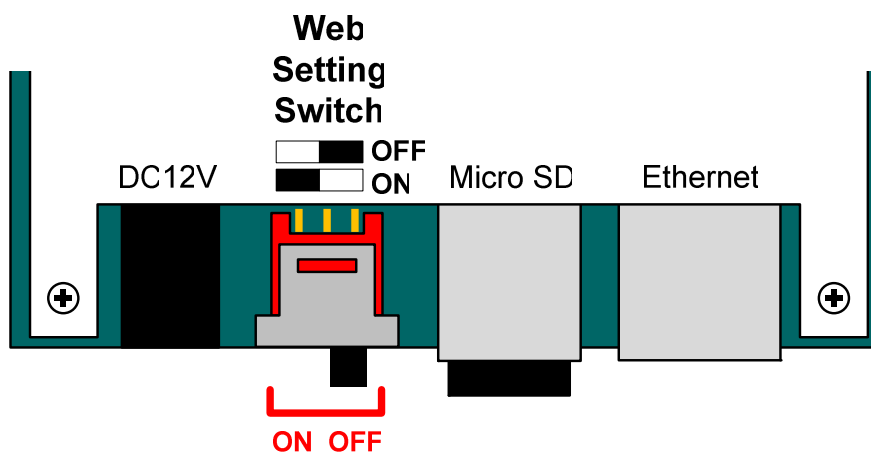

Figure 7-7

### 7.3.2 Resetting the GV-EV48

To reset GV-EV48, press the **Reset** button on the right side of GV-EV48 circuit board for three seconds.

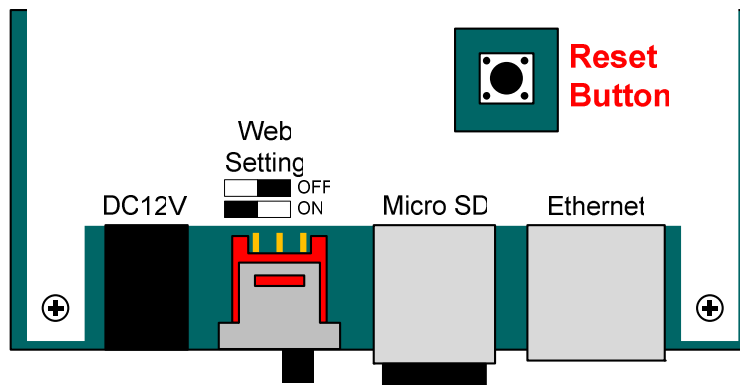

Figure 7-8

### 7.3.3 Restoring Factory Defaults

To restore GV-EV48 to factory default settings, press the **Default** button for 10 seconds.

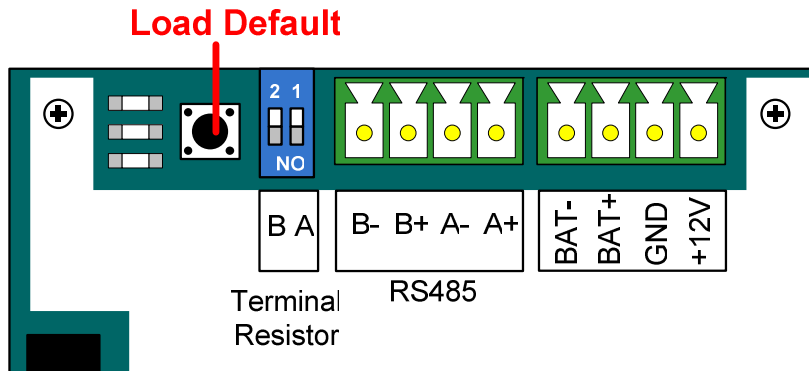

Figure 7-9

## 7.4 The Web Interface

You can install GV-EV48 on a network and configure GV-EV48 through its Web interface.

Refer to *Chapter 8 Installing on a Network* for detailed instructions on setting up a fixed or dynamic IP address to access GV-EV48.

Refer to *Chapter 9 The Web Interface* for details on the setup pages of the Web interface. Through the Web interface, you can configure general settings, specify which floors are restricted and establish connection with associated readers.

## 7.5 GV-EV48 Specifications

CPU	32-bit ARM7TDMI	
Number of User Cards	40,000 cards	
Event Buffer	1,000,000 events and log data	
Power	100~250V AC, 50~60 Hz	
RS-485 Interface	1 RS-485 interface only for GV-Readers and GV-GF Fingerprint Readers (max. 2 readers)	
Communication	TCP/IP	
Output	GV-EV48-24 Floors	24 relay outputs (30VDC, 1A; 125V AC, 0.3A)
	GV-EV48-48 Floors	48 relay outputs (30VDC, 1A; 125V AC, 0.3A)
Operating Temperature	0 ~ 65°C / 32 ~ 149°F	
Operating Humidity	10% ~ 90% RH (non-condensing)	
Dimensions (W X H X D)	210 x 170 x 55 mm / 8.27 x 6.69 x 2.17 in	
Weight	610 g / 1.34 lb	
Certification	CE, FCC, RoHS	

All specifications are subject to change without notice.

## **8. Installing on a Network**

You can install GV-AS210 / 400 / 410 / 810 and GV-EV48 on a network and set up general settings, doors/gates/elevators, readers, and input/output devices through its Web interface. Through the network connection, you can also connect GV-AS / GV-EV Controller to GV-ASManager for more comprehensive management.

---

**Note:** To access the Web interface of GV-AS100 / 110 / 120 and allow communication with GV-ASManager over the network, a GV-ASBox or GV-ASNet is required. Refer to *Chapter 10 Optional Devices* for more details.

---

The GV-AS / GV-EV Controller must first be assigned an IP address to make it accessible on the network.

1. Connect the network cable to the **Ethernet** port on GV-AS / GV-EV Controller.
2. Use a computer on the same LAN with the controller to assign an IP address.
  - The default address is <https://192.168.0.100>
  - The default Username and Password for login are **admin**

Note the computer used to set the IP address must be on the same network or subnet sequence assigned to the controller.

3. GV-AS / GV-EV Controller is able to support two network environments: **Fixed IP** for a static IP address and **DHCP** for a dynamic IP address assigned by an ISP or DHCP server. Based on your network environment, refer to the next two sections for setup.

## 8.1 Fixed IP Connection

If your network environment supports a static IP address, the wiring is illustrated as below:

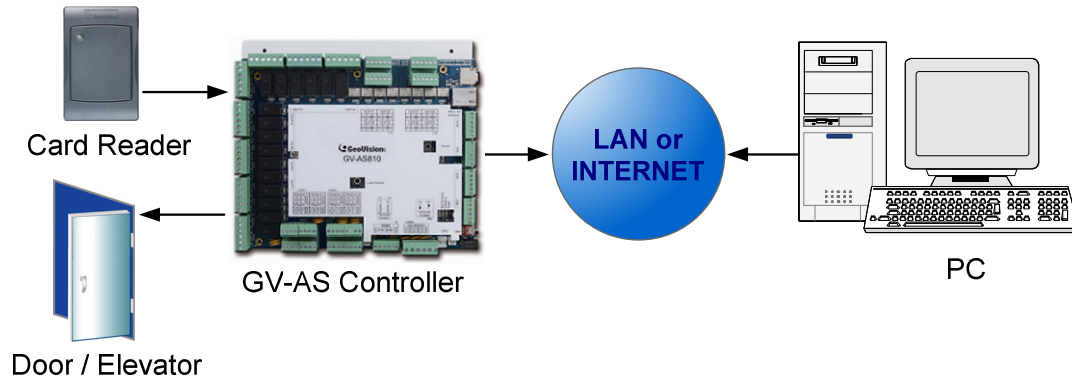

Figure 8-1

To assign the GV-AS / GV-EV Controller to a fixed IP:

1. Open an Internet browser, and type the default IP address <https://192.168.0.100>. This dialog box appears.

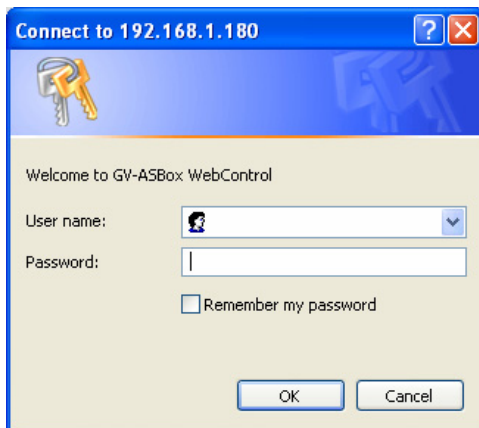

Figure 8-2



- Click default value **admin** for both User name and Password, and click **OK**. This page appears.

The screenshot displays the 'Network Configuration' interface. On the left is a navigation menu with sections: 'Basic Setting' (Network Setting, Other Setting, Firmware Update, Account Setting), 'Advance Setting' (Function Setting, Parameter Setting, Status Monitor, Card Information, Time Setting, In/Out Function), and 'Extend Device' (Extend Reader). The main content area is titled 'Network Configuration' and includes the following sections:

- Machine Name:** Controller 10
- DHCP Client:**
  - Enable
  - Disable (highlighted with a red box)
  - IP Address:** 192 | 168 | 2 | 119
  - Subnet Mask:** 255 | 255 | 252 | 0
  - Default Gateway:** 192 | 168 | 0 | 1
  - Domain Name Server:** 0 | 0 | 0 | 0
- Domain Name Service:**
  - Disable
  - Send to LocalDDNS
  - Server IP:** 192 | 168 | 0 | 10
  - Device Name:** user

Figure 8-3

- In the **DHCP Client** section, click **Disable**. Type the static IP address information, including IP Address, Subnet Mask, Default Gateway and Domain Name Server.
- Click **Submit**. When the setting is complete, the Status field will indicate *Register Success*. Then GV-AS / GV-EV Controller can be accessed with this fixed IP address.

---

**Note:** If you like to use the domain name instead of IP address, you may use Domain Name Service as well. For details on domain name service, see [7.2 DHCP Connection](#).

---

## 8.2 DHCP Connection

If your network environment is using the dynamic IP address from a DHCP server, use one of the following DDNS servers to map a dynamic IP address to a static domain name or device name:

- For LAN connection, GV LocalDDNS Server is provided.
- For Internet connection, two DDNS servers are supported: GeoVision DDNS Server and Dynamic Network Services Inc. (DynDNS).

### 8.2.1 Connection over LAN

GeoVision's **GV LocalDDNS Server** can map the changing IP address of your controller to a device name, allowing you to access the controller using the device name.

The Local DDNS Server can be installed in either GV-ASManager or a separate computer. The wiring of the LocalDDNS application is illustrated as below.

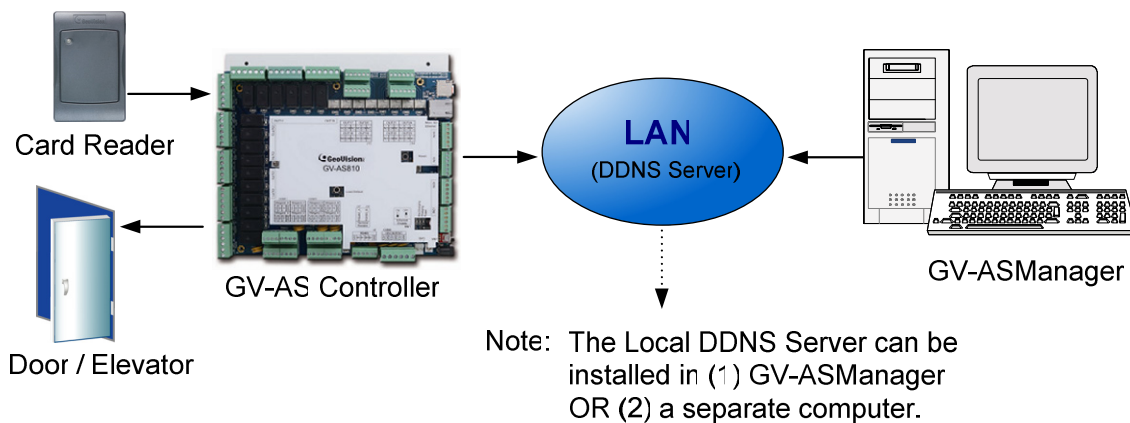

Figure 8-4

## Installing LocalDDNS Server

To install the LocalDDNS Server in a computer, insert the Software DVD. It will run automatically and a window appears. Select **Install GeoVision Access Control System**, click **GeoVision Dynamic DNS Service** and follow the on-screen instructions.

After Installation, the program will be minimized to the system tray.



## Configuring Controller on LAN

After running the LocalDDNS Server, configure the controller on LAN:

1. Open an Internet browser, and type the default IP address <https://192.168.0.100>. The login dialog box (Figure 8-2) appears.
2. In the User Name and Password fields, type default value **admin** and **admin** respectively. Click **OK**. The Network Configuration page (Figure 8-5) appears.
3. Click **Enable**, and select **Send to Local DDNS**.
4. In the Server IP fields, type the IP address of the LocalDDNS Server.
5. In the Device Name field, keep the default setting or change it to match that of the GV-ASManager.

**GeoVision**

**Basic Setting**

- Network Setting
- Other Setting
- Firmware Update
- Account Setting

**Advance Setting**

- Function Setting
- Parameter Setting
- Status Monitor
- Card Information
- Time Setting
- In/Out Function

**Extend Device**

- Extend Reader

**Network Configuration**

**Machine Name**

Machine Name: Controller 10

**DHCP Client**

Enable

Disable

IP Address: 192 . 168 . 2 . 119

Subnet Mask: 255 . 255 . 252 . 0

Default Gateway: 192 . 168 . 0 . 1

Domain Name Server: 0 . 0 . 0 . 0

**Domain Name Service**

Disable

Send to LocalDDNS

Server IP: 192 . 168 . 0 . 10

Device Name: user

Send to DDNS

Host Name: user.dipmap.com

Figure 8-5

6. Click **Submit** to send the information to the LocalDDNS Server. When the setting is complete, the Status field will indicate: *Register Success*. Then the controller can be accessed with the device name.

---

**Note:**

1. The default value of Device Name is **user**. If more than one controller is connected to the GV-ASManager, assign each controller a different device name.
2. To access the **Device Name** on GV-ASManager, open the Controller Setup dialog box, and select **LocalDDNS** in the Network drop-down list.

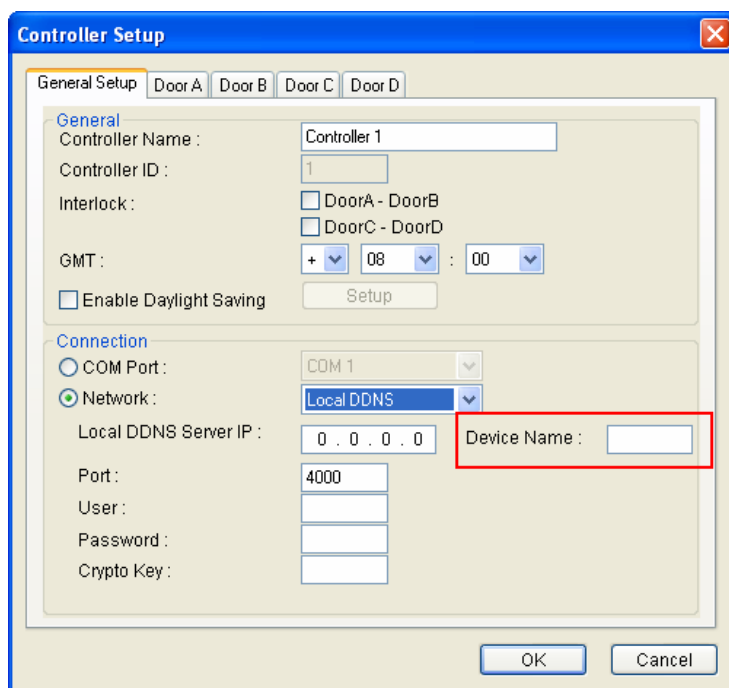

Figure 8-6

## 8.2.2 Connection over Internet

DDNS (Dynamic Domain Name System) provides another way of accessing GV-AS / GV-EV Controller when using a dynamic IP. DDNS assigns a domain name to the controller, so the GV-ASManager can always access the controller by using the domain name.

To enable the DDNS function, you should first apply for a domain name from the website of the DDNS service provider. There are 2 providers listed in the controller: GeoVision DDNS Server and DynDNS.org. To register at the GeoVision DDNS Server, see the following instructions. For details on DynDNS, please consult them at [www.dyndns.org](http://www.dyndns.org).

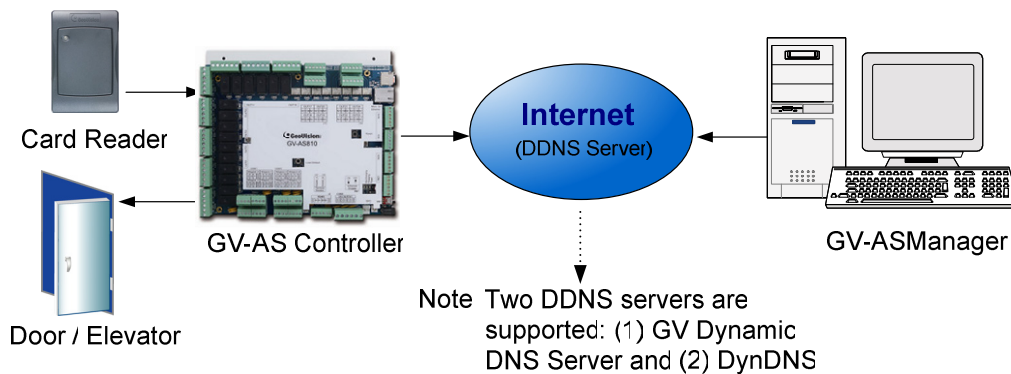

Figure 8-7

### Registering a DDNS Domain Name

To obtain a domain name from the GeoVision DDNS Server:

1. Click the **GeoVision DDNS** button on the Network Configuration page (Figure 8-5). Or open an Internet browser, and type the Web address <http://ns.dipmap.com/register.aspx>. This page appears.

## DynamicDNS01

**Register**

<p>Username: <input type="text" value="Somerset01"/></p> <p>Password: <input type="password" value="*****"/></p> <p>Re-type Password: <input type="password" value="*****"/></p>	<p><b>Username</b></p> <p>Username is 16-character maximum; username may not start with spaces or minus signs (-). Username will be your hostname.</p> <p><b>Password</b></p> <p>The password is case-sensitive.</p>
<p>Enter the characters as they are shown in the box below. <input type="text" value="i8UCY"/></p> 	<p><b>Word Verification</b></p> <p>This step helps us prevent automated registrations.</p>

Figure 8-8

2. In the Username field, type a name. Username can be up to 16 characters with the choices of “a ~ z”, “0 ~9”, and “-”. Note that space or “-” cannot be used as the first character.
3. In the Password field, type a password. Passwords are case-sensitive and must be at least 6 characters. Type the password again in the Re-type Password field for confirmation.
4. In the Word Verification section, type the characters or numbers shown in the box. For example, type *i8UCY* in the required field. Word Verification is not case-sensitive.
5. Click the **Send** button. When the registration is complete, this page will appear. The **Hostname** is the domain name, consisting of the registered username and “dipmap.com”, e.g. somerset01.dipmap.com.

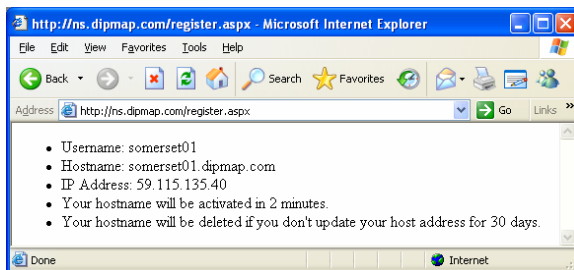

Figure 8-9

---

**Note:** The registered username will be invalid when it is not used for one month.

---

## Configuring the GV-AS / GV-EV Controller on Internet

After acquiring a domain name from the DDNS Server, you need to configure the registered domain name on the controller to access the controller by the domain name on Internet.

1. Open an Internet browser, and type the default IP address <https://192.168.0.100>. The login dialog box (Figure 8-2) appears.
2. In the User Name and Password fields, type default value **admin** and **admin** respectively. Click **OK**. The Network Configuration page (Figure 8-10) appears.
3. Click **Enable**, and select **Send to DDNS**.
4. Type **Host Name**, **User Name** and **Password** that are registered on the DDNS Server. If you select **GeoVision DDNS**, the system will automatically bring up the Host Name.

The screenshot displays the 'Network Configuration' page in the GeoVision web interface. On the left is a navigation menu with categories like 'Basic Setting' and 'Advance Setting'. The main content area is titled 'Network Configuration' and includes sections for 'Machine Name', 'DHCP Client', and 'Domain Name Service'. The 'DHCP Client' section has 'Enable' selected. The 'Domain Name Service' section has 'Send to DDNS' selected, and the 'Send to DDNS' option is highlighted with a red box. Below this, the 'Host Name' field contains 'user.dipmap.com', and the 'User Name' and 'Password' fields are empty.

Figure 8-10

5. Click **Submit**. When the setting is complete, the Status field will indicate: *Register Success*. Then GV-AS / GV-EV Controller can be accessed with the domain name.

## **9. The Web Interface**



After installing the GV-AS / GV-EV Controller on the network, you can configure the controller settings on the Web interface. The left menu of the Web interface is divided into three sections: **Basic Setting**, **Advanced Setting** and **Extended Device**. The options available vary among different controller models.

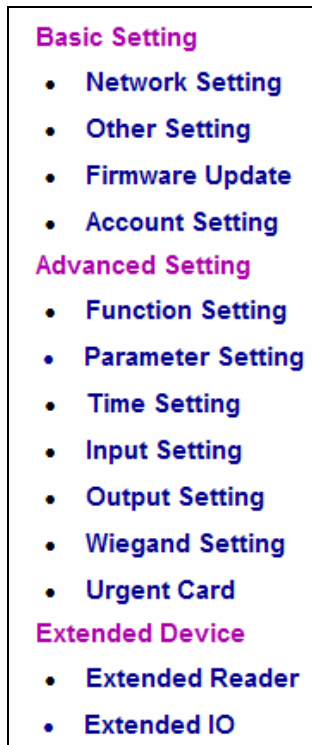

Figure 9-1

## 9.1 Basic Settings

The Basic Settings section covers general system settings, firmware update and user account settings. For details on Network Setting, refer to *Chapter 8 Installing on a Network*.

### 9.1.1 System Setup

In the left menu, click **Other Setting**. This page appears.

**Other Configuration**

---

**3DES Code**

3DES Code1  ( characters 8 ~ 24 )

3DES Code2  ( option )

3DES Code3  ( option )

---

**Device Port**

Device Port  ( from 1025 to 65535 )

---

**SD Card**

Capacity total: 1925464kB free: 1838788kB (95.27%)

---

**Mac Address / Firmware Version**

Mac Address 00:13:e2:0a:92:41

Firmware Version V1.2.2-20140414

---

**Reboot System / Set Default**

Reboot System

Default Value

Figure 9-2

- **3DES Code 1-3:** Stands for Triple DES (Data Encryption Standard). Type up to three different keys for data encryption. The default 3DES Code1 is **12345678**.
- **Device Port:** Keeps the default value **4000**. Or modify it to match that of GV-ASManager.
- **SD Card:** Indicates capacity of the SD card inserted and allows you to format the SD card. This function is only available for GV-AS210 / 410 / 810.
- **Mac Address:** Indicates the MAC address of the network medium.

- **Firmware Version:** Indicates the current firmware version of the controller.
- **Reboot System:** Performs a warm boot of the controller. This operation will keep the current configuration.
- **Default Value:** Resets all configuration parameters to their factory settings. This may take 5 seconds to complete.

## 9.1.2 Upgrading Firmware

Follow the steps below to update the firmware of the controller.

To upgrade the firmware of GV-AS400, an extra step is required. You need to prepare a **Jumper** and plug it into **JP7**, or plug GV-ASKeypad to GV-AS400.

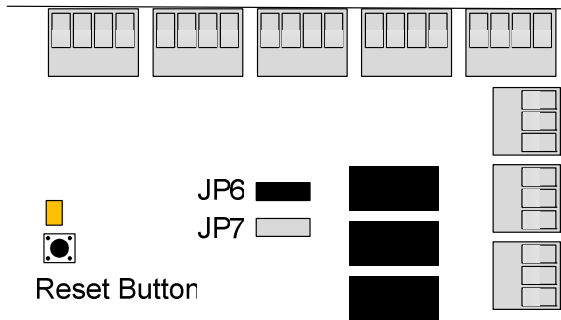

Figure 9-3

### To Upgrade Firmware:

1. In the left menu, click **Firmware Update**. This page appears.

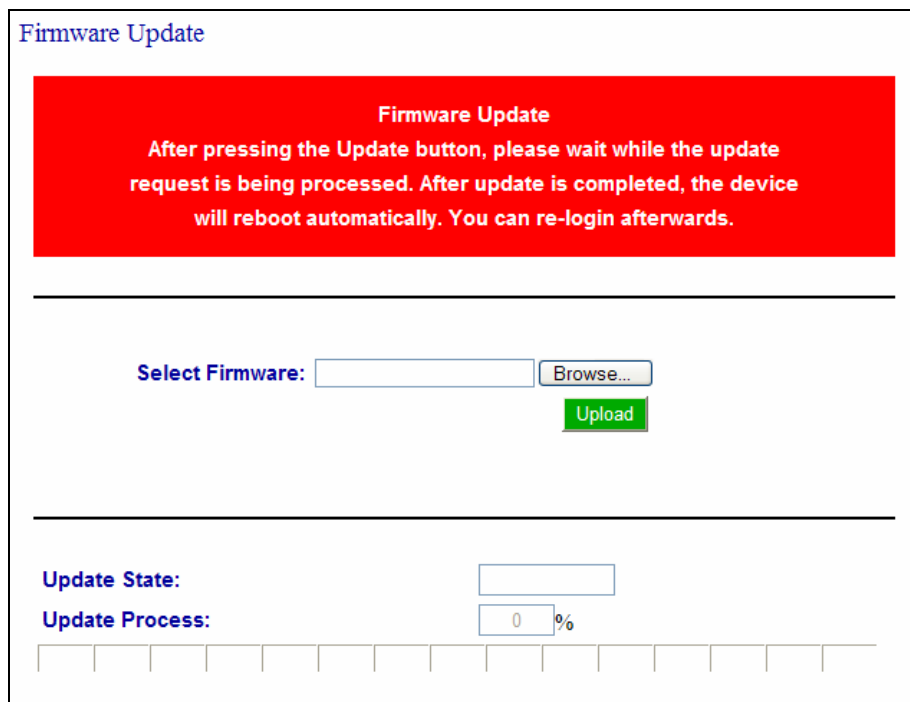

Figure 9-4

2. Click the **Browse...** button to open the firmware file (\*.bin)
3. Click the **Upload** button. This update procedure may take 60 seconds to complete.

4. When the Update is complete, a dialog box appears and asks you to reboot the system.



*Figure 9-5*

5. Click **OK**. The controller starts the Reboot operation.

---

**Note:**

1. Make sure the controller remains powered on during the firmware upgrade.
  2. It is required to reboot controller after firmware update. Without rebooting, the firmware update is not complete.
-

## 9.1.3 Changing Login ID and Password

To change the login ID and password:

1. In the left menu, click **Account Setting**.
2. On the Security Configuration page, modify the login name and password. The password is case sensitive and is limited to alphabets and numbers.

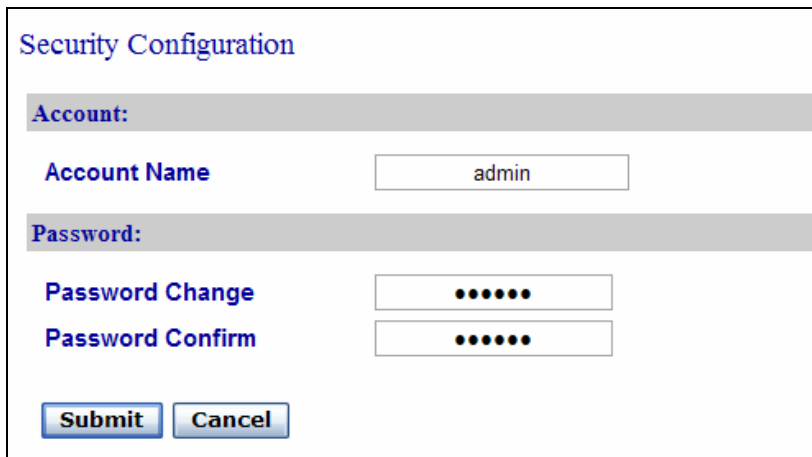

The screenshot displays the 'Security Configuration' page. It features a header 'Security Configuration' in blue. Below this, there are two main sections: 'Account:' and 'Password:'. The 'Account:' section includes a label 'Account Name' and a text input field containing the value 'admin'. The 'Password:' section includes two labels, 'Password Change' and 'Password Confirm', each followed by a password input field filled with black dots. At the bottom of the form, there are two buttons: 'Submit' and 'Cancel'.

Figure 9-6

## 9.2 Advanced Settings

To configure the Advanced Setting on the Web interface, set the **Web Setting** switch on the GV-AS / GV-EV Controller to ON. See the *Web Setting Switch* section of each controller chapter.

Under Advanced Settings, you can configure door/Wiegand settings, turn on Alarms, set the device time and edit the input/output functions.

For GV-AS210 / 400 / 410 / 810, the changes in some of the Advanced Settings page will affect the options available on other pages. Below is a diagram drawing the relationships between each Advanced Settings page.

### The Relationship Diagram between each Advanced Setting Page

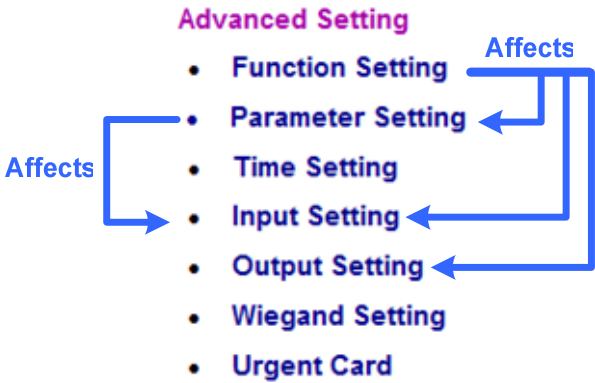

Figure 9-7

---

**Note:** The Urgent Card setting page is only available for GV-AS400.

---

For GV-EV48, the options available in Advanced Settings page are fixed. Only the following setting pages are available:

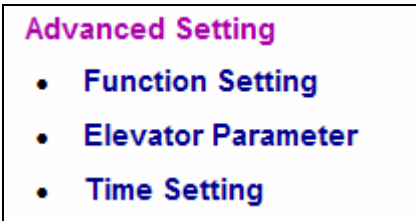

Figure 9-8

## 9.2.1 Function Setting

In the left menu, click **Function Setting**. The **Function Configuration** page appears. The number of door/gate settings or elevator settings available varies among different models.

**Function Configuration**

---

**ID**

ID

---

**Door/Gate A**

Function

Authentication Mode

---

**Door/Gate B**

Function

Authentication Mode

---

**Door/Gate C**

Function

Authentication Mode

---

**Door/Gate D**

Function

Authentication Mode

---

**Anti-Passback**

Enable/Disable

Info IP

Figure 9-9

---

**Note:** For GV-EV48, only the ID and the Authentication Mode settings are available.

---

### [ID]

Enter the ID number for the controller. This ID is used by GV-ASManager to differentiate among multiple units of controller. ID number can only be between 1 and 255.



**[Door/Gate #] [Elevator]**

Select the function type and authentication mode for the use of the Doors/Gates. For GV-EV48, select an authentication mode to apply to all floors of the elevator.

- **Function:** Select the function for the reader connected to the Door/Gate.
  - ⊙ **Door Control:** The reader is installed in a general door for access control.
  - ⊙ **Parking Control:** The reader is installed in a parking place for access control.
  - ⊙ **Elevator Control:** The reader is installed in an elevator for access control.
- **Authentication Mode:** Select the authentication mode for the Doors/Gates or Elevator.
  - ⊙ **Local Unlock Mode:** Remains open. The held-open state cannot be cleared through GV-ASManager.
  - ⊙ **Local Lock Mode:** Remains locked. The locked state cannot be cleared through GV-ASManager.
  - ⊙ **Fixed Card Mode:** Grants access after the card is presented and ignores the authentication schedule of GV-ASManager.
  - ⊙ **Fixed Card + PIN Mode:** Grants access after the user presents the card and enters the card's PIN code, and ignores the authentication schedule of GV-ASManager.
  - ⊙ **Fixed Card/Common mode:** Grants access after the user presents the card or enters the door's password, and ignores the authentication schedule of GV-ASManager.
  - ⊙ **Authentication Schedule Mode:** Follows the authentication schedule set on GV-ASManager.

**[Anti-Passback]**

This option lets you set the Anti-Passback function across multiple door controllers. The Anti-Passback means that a card used on an entry door cannot access the same entry door again unless it has been used on a corresponding exit door. For details on setup, see *Chapter 6 Anti-Passback on GV-ASManager User's Manual*.

- **Enable/Disable:** Enables or disables the Anti-Passback function.
- **Info IP:** Enter the IP address of the next corresponding controller.

Click **Submit** button to save the changes, or click **Cancel** button to return the changes to its previous state.

## 9.2.2 Parameter Setting

In the left menu, click **Parameter Setting** for GV-AS210 / 400 / 410 / 810 or click **Elevator Parameter** for GV-EV48. The **Parameter Configuration** page appears.

---

**IMPORTANT:** Once connecting to GV-AS / GV-EV Controller, GV-ASManager will load its parameters to the controller. That means some of the Parameter Settings you have configured here may be overwritten by GV-ASManager later.

---

### 9.2.2.A GV-AS210 / 400 / 410 / 810

The contents of Parameter Setting change based on your settings for **Door/Gate #** in the **Function Setting** page (Figure 9-9). The number of door/gate settings available varies among different models.

**Parameter Part1 Configuration**

---

**Events**

<p><b>Door 1</b></p> <p>Anti-passback <input type="text" value="NO"/> <small>(1~255)</small></p> <p>Lock Reset Time <input type="text" value="5"/> <small>(1~255)</small></p> <p>Held Open Time <input type="text" value="10"/> <small>(5~9999)</small></p> <p>Fire Action <input type="text" value="Unchange"/></p> <p>Alarm Continuous Time <input type="text" value="5"/> <small>(1~10)</small></p>	<p><b>Gate 2</b></p> <p>Anti-passback <input type="text" value="NO"/> <small>(1~255)</small></p> <p>Relay On Time <input type="text" value="5"/> <small>(1~255)</small></p> <p>Held Open Time <input type="text" value="10"/> <small>(5~9999)</small></p> <p>Fire Action <input type="text" value="Unchange"/></p> <p>Alarm Continuous Time <input type="text" value="5"/> <small>(1~10)</small></p>
--	--

---

**Alarm**

<p><b>Door 1</b></p> <p>Held Open <input type="text" value="YES"/></p> <p>Forced Open <input type="text" value="YES"/></p> <p>Fire Alarm <input type="text" value="YES"/></p> <p>Access Denied <input type="text" value="YES"/></p> <p>Tamper <input type="text" value="YES"/></p> <p>Tailgating <input type="text" value="YES"/></p>	<p><b>Gate 2</b></p> <p>Held Open <input type="text" value="YES"/></p> <p>Fire Alarm <input type="text" value="YES"/></p> <p>Access Denied <input type="text" value="YES"/></p> <p>Tamper <input type="text" value="YES"/></p>
---	--

---

**Common Password**

<p><b>Door 1</b></p> <p>Common Password <input type="password" value="●●●●●●●●"/></p> <p>Password Confirm <input type="password" value="●●●●●●●●"/></p>	<p><b>Gate 2</b></p> <p>Common Password <input type="password" value="●●●●●●●●"/></p> <p>Password Confirm <input type="password" value="●●●●●●●●"/></p>
---	---

Figure 9-10

**[Interlock]** When the option is enabled, the two mentioned doors will be interlocked, allowing only one door to be opened at a time.

**Note:** The Interlock function is not available on GV-AS210 / 410 / 810.

**[Events]**

Set the parameters for the events.

- When **Door Control** is selected in the **Function Setting** page (Figure 9-9), these options become available:

Option	Description
Anti-Passback	Enables or disables the Anti-Passback function.
Lock Reset Time	Sets the time (1 to 255 sec.) that a door remains open after which the door will automatically be locked.
Held Open Time	Sets the time (5 to 9999 sec.) that a door can be held open before an alarm is generated.
Fire Action	Locks or unlocks the door when a fire condition occurs. Otherwise, remains the door's current state by selecting <i>Unchanged</i> .
Alarm Continuous Time	Sets the time (1 to 10 sec.) that the alarm will continuously go off before it ends.

- When **Parking Control** is selected in the **Function Setting** page (Figure 9-9), these options become available:

Option	Description
Anti-Passback	See the same option above.
Relay On Time	Sets the time (1 to 255 sec.) that a gate remains open after which the gate will automatically be closed.
Held Open Time	See the same option above.
Fire Action	
Alarm Continuous Time	

- When **Elevator Control** is selected in the **Function Setting** page (Figure 9-9), these options become available:

Option	Description
Relay on Time	See the same option above.
Fire Action	
Alarm Continuous Time	See the same option above.

### [Alarm]

Select **Yes** or **No** to enable or disable the alarm function. If you have defined the alarm conditions in the **Input Setting** page (Figure 9-14), remember to activate the corresponding alarms here; otherwise, even though the alarm conditions are met, the expected alarm will not be triggered. The default settings for all the alarms are set to **NO**.

---

**Note:** The Tailgating alarm is currently not functional.

---

- When **Door Control** is selected in the **Function Setting** page (Figure 9-9), these options become available:

Option	Description
Held Open	This alarm activates whenever the door is held open over the set period of time.
Forced Open	This alarm activates whenever the door is opened by force.
Fire Alarm	This alarm activates whenever fire is detected.
Access Denied	This alarm activates whenever entry is denied due to using the wrong card or entering the wrong password.
Tamper	This alarm activates whenever vandalism occurs, e.g. the opening of controller's cabinet.

- When **Parking Control** is selected in the **Function Setting** page (Figure 9-9), these options become available:

Option	Description
Held Open	See the same option above.
Tamper	
Fire Alarm	
Access Denied	

- When **Elevator Control** is selected in the **Function Setting** page (Figure 9-9), these options become available:

Option	Description
Tamper	See the same option above.
Fire Alarm	
Access Denied	

**[Common Password]**

When **Fixed Card/Common Mode** is selected as **Authentication Mode** in the **Function Setting** page (Figure 9-9), you can gain access by using a card or entering this Common Password (door's password).

The screenshot shows a form titled "Common Password" with a grey header. Below the header are two rows of input fields. The first row is labeled "Common Password" and the second row is labeled "Password Confirm". Both input fields are masked with black dots. The form is enclosed in a thin black border.

Figure 9-11

Click **Submit** button to save the changes, or click **Cancel** button to return the changes to its previous state.

### 9.2.2.B GV-EV48

The Parameter Setting page allows you to specify which elevator floors are restricted.

**Parameter Configuration**

---

**Events**

Relay On Time  (1~255)

---

**Common Password**

Common Password

Password Confirm

---

**Unmanaged output**

Checked output pins are in unmanaged mode

Toggle All

Out1  Out2  Out3  Out4  Out5  Out6  Out7  Out8  
 Out9  Out10  Out11  Out12  Out13  Out14  Out15  Out16  
 Out17  Out18  Out19  Out20  Out21  Out22  Out23  Out24  
 Out25  Out26  Out27  Out28  Out29  Out30  Out31  Out32  
 Out33  Out34  Out35  Out36  Out37  Out38  Out39  Out40  
 Out41  Out42  Out43  Out44  Out45  Out46  Out47  Out48

Figure 9-12

**[Events]**

- Relay On Time:** Type a time period between 1-255 seconds. After access is granted by swiping a card or entering the password, the elevator button will remain accessible for the time period specified. After the specified time period, the elevator buttons for restricted floors will be locked again.

**[Common Password]**

When **Fixed Card/Common Mode** is selected as **Authentication Mode** in the **Function Setting** page (Figure 9-9), you can gain access by using a card or entering this Common Password (elevator's password).

---

**Note:** Users typing the correct Common Password will be granted access to all floors enabled on GV-ASManager. To apply access control to specified floors, you will need to use the identification card or type the card's PIN code.

---

**[Unmanaged Output]**

Elevator floors of the selected output pins will be unrestricted and accessible without card or password. **Authentication Mode** configured in **Function Setting** page will only be applied to output pins that are not selected. To select all output pins or to clear all selections, click **Toggle All**.

---

**Note:** For GV-EV48-24 Floors, output pins 25-48 are not functional.

---

Click **Submit** button to save the changes, or click **Cancel** button to return the changes to its previous state.

## 9.2.3 Time Setting

In the left menu, click **Time Setting** to set up system time, local time and daylight saving time period.

**Time Configuration**

---

**System Local Time**

**Local Time** 2012/08/20 15:45:13

**Time Zone** +8:00

---

**Local Time**

**Disable**

**Setup**

**TimeZone**      **Hour**    **Min**

0    0

**Date**            **Year**    **Month**    **Date**

2009    January    1

**Time**            **Hour**    **Min**      **Sec**

0    0      0

---

**Daylight Savings Time(DST)**

**Disable**

**Enable**

**Start Time**            **Month**      **Date**    **Hour**

January    31    0

**Stop Time**            **Month**      **Date**    **Hour**

January    31    0

Figure 9-13

### [System Local Time]

- **Local Time:** Displays the current date and time of the controller.
- **Time Zone:** Displays the current time zone of the controller.

### [Local Time]

- **Disable:** Disable the manual configuration of time and date.
- **Setup:** Enable the manual configuration of **Time Zone**, **Date** and **Time** for the controller.



**[Daylight Savings Time (DST)]**

- **Disable:** Disable the manual configuration of DST.
- **Time Zone:** Enable the manual configuration of DST by setting the **Start Time** and **Stop Time** for the DST period.

Click **Submit** button to save the changes, or click **Cancel** button to return the changes to its previous state.

## 9.2.4 Input Setting

In the left menu, click **Input Setting** to define the input devices connected to the GV-AS Controller. The number of input devices supported varies among different models.

**Note:** The Input Setting page is not available for GV-EV48.

AS210 Input Configuration

Input Function			
01	AS210_IN1	NO	Door A Door Contact
02	AS210_IN2	NO	Gate B Car Detection
03	AS210_IN3	NO	Relay C Fire Zone
04	AS210_IN4	NO	Door D Tamper Zone
05	AS210_IN5	NO	Door A Tamper Zone
06	AS210_IN6	NO	Gate B Tamper Zone
07	AS210_IN7	NO	Relay C Tamper Zone
08	AS210_IN8	NO	Door D Tamper Zone

Submit Cancel

Figure 9-14

Here you can name and set the input state to trigger actions by selecting **NO (Normally Open)** or **NC (Normally Closed)**. Normally open circuits connect the circuit when input is triggered and normally closed circuits disconnect the circuit when input is triggered.

**Note:** The NO / NC option is only available for GV-AS210 / 410 / 810. For GV-AS400, inputs can be set to NO or NC using a physical switch on the GV-AS400 board. Input devices connected to GV-AS100 / 110 / 120 will use NO (Normally Open) circuit.

AS210 Input Configuration

Input Function			
01	AS210_IN1	NO	Door A Door Contact
02	AS210_IN2	NO	Gate B Car Detection
03	AS210_IN3	NO	Relay C Fire Zone
04	AS210_IN4	NO	Door D Tamper Zone

1 2

Figure 9-15

1. **Input Type:** Configure the input type. Input Type defines the type of sensor that is connected to the input of GV-AS Controller. Options available for the input type change based on your settings of **Door/Gate #** in the **Function Setting** page (Figure 9-9).
2. **Input Function:** Configure the input function. Options available for the input function change based on the settings of **Input Type** above.

Input Type	Input Function	Description
Normal Input	Enable Latch Disable Latch	The Normal Input is used for a normal detection mode in which the input is set to trigger an output. Instead of constant output alarm in N/O and N/C, the <b>Enable Latch</b> option provides a momentary alarm when triggered.
Door #	Fire Zone Tamper Zone Exit Button Door Contact	Depending on the type of sensor and the location where it is installed, select the most suitable Input Function name to describe the sensor. When the sensor is activated, an alarm event may occur and it can also trigger alarms. For the type of alarm, see [Alarm], <i>8.2.2 Parameter Setting</i> .  For example, when the <b>Door Contact</b> sensor detects unauthorized access, a “Force Open” type of event occurs and the event may trigger the “Force Open” alarm.
Gate #	Fire Zone Tamper Zone Exit Button Car Detection	See the “Door #” Input Type above.  For example, when the <b>Car Detection</b> sensor detects any car driving by, a “Park Entry” or “Park Exit” type of event occurs and the parking gate will respond the event accordingly.
Relay #	Fire Zone Tamper Zone	See the “Door #” Input Type above.  For example, the <b>Tamper Zone</b> sensor is installed on GV-AS Controller. So whenever there is any attempt to open the GV-AS Controller’s cabinet, the “Tamper” type of event occurs and the event may trigger the “Tamper” alarm.

**Note:**

1. For alarm outputs, the corresponding alarms must be enabled (YES) in the **Parameter Setting** page (Figure 9-10). If alarms are set to be disabled (NO), then the alarm function here will not work when triggered.
2. After upgrading the GV-AS400 from previous firmware versions to version 1.03 or later, you must first load default to be able to name the sensor inputs.

## 9.2.5 Output Setting

In the left menu, click **Output Setting**. The **Output Configuration** page appears. The number of output devices supported varies among different models.

---

**Note:** The Output Setting page is not available for GV-EV48.

---

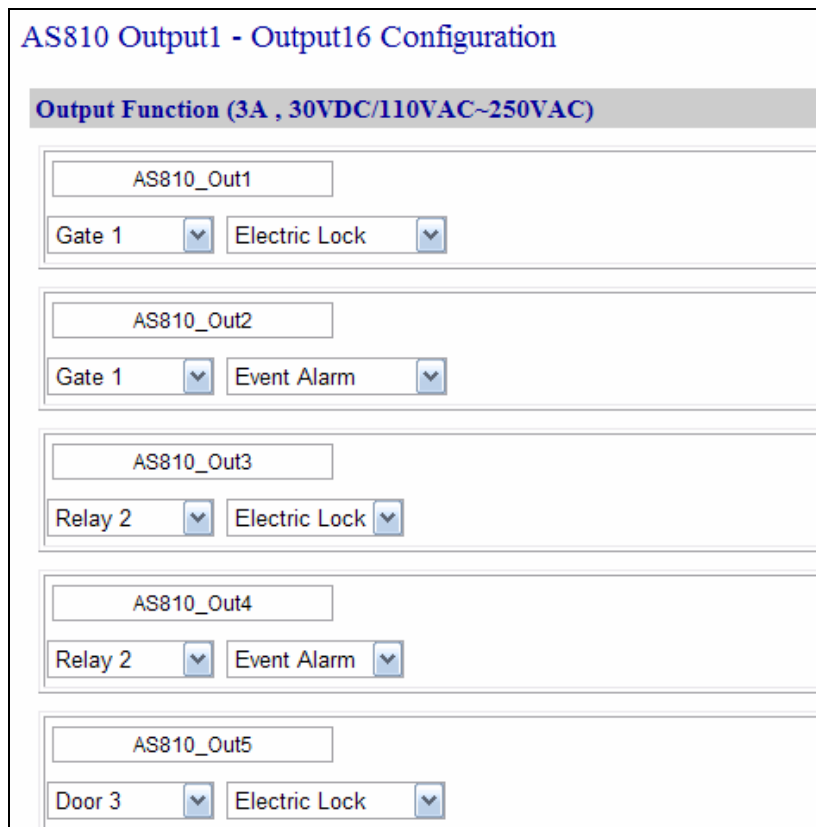

AS810 Output1 - Output16 Configuration

**Output Function (3A , 30VDC/110VAC~250VAC)**

AS810_Out1	Gate 1	Electric Lock
AS810_Out2	Gate 1	Event Alarm
AS810_Out3	Relay 2	Electric Lock
AS810_Out4	Relay 2	Event Alarm
AS810_Out5	Door 3	Electric Lock

Figure 9-16

Here you can name and define each output device connected to the GV-AS Controller, such as locking devices and Exit Button. Select from the drop-down list to configure the **Output Type** (No. 1, Figure 9-17). Depending on the chosen **Output Type**, either **Output Function** (No. 2, Figure 9-17) or **Output Conditions** (No. 3, Figure 9-17) will become available.

The screenshot shows the 'AS810 Output1 - Output16 Configuration' page. At the top, it specifies 'Output Function (3A , 30VDC/110VAC~250VAC)'. There are two configuration sections:

- AS810\_Out1:** Labeled with a red '1' next to the name field and a red '2' next to the 'Output Type' dropdown. The 'Output Type' is set to 'Electric Lock'. The 'Output Function' dropdown is set to 'Gate 1'.
- AS810\_Out2:** Labeled with a red '1' next to the name field and a red '3' next to the 'Output Conditions' section. The 'Output Type' is set to 'Normal'. The 'Output Conditions' section includes a timer set to '0 Sec', followed by an equals sign and a complex condition: 'Door 3' (dropdown) AND 'Door 4' (dropdown) AND 'Access Granted' (dropdown) AND 'Access Granted' (dropdown) AND 'Wiegand A' (dropdown) AND 'Wiegand B' (dropdown). A 'Reset' button is located at the end of this section.

Figure 9-17

---

**Note:** After upgrading GV-AS400 from previous firmware versions to version 1.03 or later, you must first load default to be able to name the sensor outputs.

---

### 9.2.5.A Output Function Settings

When **Output Type** (No. 1, Figure 8-15) is set to be **Door #**, **Gate #** or **Relay #**, the options similar to the figure below become available.

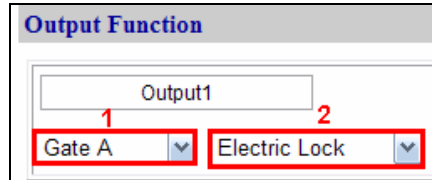

Figure 9-18

Below is the explanation based on the numbers marked on the figure above.

1. **Output Type:** Configure the output type. Options available for the output type change based on your settings of **Door / Gate #** in the **Function Setting** page (Figure 9-9).
2. **Output Function:** Configure the output function. Options available for the output function change based on your setting of **Output Type** above.

- When **Door #** is selected as **Output Type**, these **Output Functions** become available:

Output #	Output Type	Output Function	Description
GV-AS210 / 410 / 810: All Outputs  GV-AS400: Output 01 ~ 08	Door #	Electric Lock	Output is triggered when the correct card is presented to open the locking device.
		Event Alarm	Output is triggered when the defined alarm events occur.
		Entry Card	Output is triggered when the correct card is presented to enter the door.
		Exit Card	Output is triggered when the correct card is presented to exit the door.
		Unlock Alarm	Output is triggered when the door is unlocked.
GV-AS400: Output 09 ~ 16	Door #	Beeper	These Output Functions are only available for <b>Output 9~ 16</b> of GV-AS400 because these outputs on GV-AS400 cannot accept external power supply.
		Green LED	
		Red LED	

- When **Gate #** is selected as **Output Type**, these **Output Functions** become available:

Output #	Output Type	Output Function	Description
GV-AS210 / 410 / 810 All Outputs  GV-AS400 Output 01 ~ 08	Gate #	Electric Lock	See the same function above.
		Event Alarm	
		Entry Card	Output is triggered when the correct card is presented to enter the parking gate.
		Exit Card	Output is triggered when the correct card is presented to exit the parking gate.
		Open Alarm	Output is triggered when the parking gate is open.
GV-AS400 Output 09 ~ 16	Gate #	Beeper	See the same function above.
		Green LED	
		Red LED	

- When **Relay** is selected as **Output Type**, these **Output Functions** become available:

Output #	Output Type	Output Function	Description
GV-AS210 / 410 / 810: All Outputs  GV-AS400 Output 01 ~ 08	Relay #	Electric Lock	See the same function above.
		Event Alarm	
		Entry Card	Output is triggered when the correct card is presented to enter the elevator.
		Exit Card	Output is triggered when the correct card is presented to exit the elevator.
GV-AS400 Output 09 ~ 16	Relay #	Beeper	See the same function above.
		Green LED	
		Red LED	

### 9.2.5.B Output Condition Settings

When **Output Type** (No. 1, Figure 8-15) is set to be **Normal**, **Toggle** or **Pulse**, the options similar to the figure below become available.

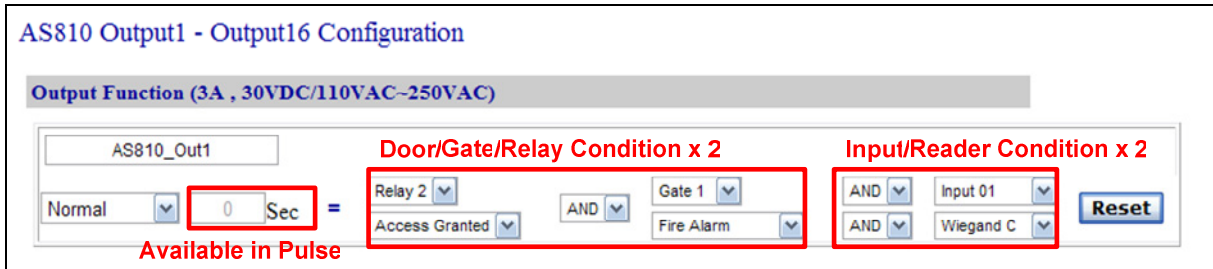

Figure 9-19

There can be a maximum of 4 conditions that can be set up to trigger an output. 2 conditions are Door/Gate/Relay conditions and 2 conditions are Input/Reader conditions. Each condition is related to each other through **AND/OR**. **AND** means that all conditions with **AND** must be triggered before the output is triggered. **OR** means that only 1 of the condition with **OR** is needed to be triggered before the output is triggered. It is also valid to have certain conditions as **AND** and certain conditions as **OR**.

For **Pulse** output type, the output is triggered for the amount of time set in the **Sec** field (seconds).

In the Output Condition settings, these **Output Type** and **Output Condition** become available:

Output Type	Output Condition			
	Door #	Gate #	Relay #	Input/Reader
Normal Toggle Pulse	Access Granted	Access Granted	Access Granted	Select <b>None</b> to disable the condition, or select an Input, Wiegand, or Reader to trigger the output.
	Access Denied	Access Denied	Access Denied	
	Fire Alarm	Fire Alarm	Fire Alarm	
	Tamper	Tamper	Tamper	
	Duress Event	Duress Event	Duress Event	
	Held Open	Held Open	/	
	Forced Open	Forced Open		
	Exit Button	Exit Button		
Door Contact	Car Detection			



Click **Reset** button to return the **Normal**, **Toggle** or **Pulse** triggered state to be normal.

---

**Note:** The **Reset** button is more commonly used for the **Toggle** output because once triggered, the output will go on forever. A **Reset** button is needed to turn it off.

---

Click **Submit** button to save the changes, or click **Cancel** button to return the changes to its previous state.

## 9.2.6 Wiegand Function

In the left menu, click **Wiegand Setting** to define the connected Wiegand readers. The number of Wiegand devices supported varies among different models.

---

**Note:** The Wiegand Function setting page is not available for GV-EV48.

---

Use the drop-down list to select the location where the Wiegand reader is installed.

AS810 Wiegand Configuration	
Wiegand Function	
Wiegand A	Door/Gate 1 Entry
Wiegand B	Door/Gate 2 Exit
Wiegand C	Door/Gate 3 Entry
Wiegand D	Door/Gate 4 Entry
Wiegand E	Door/Gate 5 Entry
Wiegand F	Door/Gate 6 Entry
Wiegand G	Door/Gate 7 Entry
Wiegand H	Door/Gate 8 Entry

Figure 9-20

## 9.2.7 Urgent Card

In the left menu, click **Urgent Card**. When the lithium battery on GV-AS400 runs out of power for more than 10 hours, GV-AS400 will be restored to default settings, causing access to be denied. When this happens, you can use the Urgent Cards added to the list below to be granted access.

---

**Note:** The Urgent Card setting page is only available for GV-AS400.

---

To set an access card to be an Urgent Card, type the card number in the **Card Number** field. Up to 16 Urgent Cards can be added.

### AS400 Urgent Card Manager

**Urgent Card Database**

No	Wiegand Bit	Card Number
1	26 Bits <input type="button" value="v"/>	<input type="text" value="30009519"/>
2	26 Bits <input type="button" value="v"/>	<input type="text" value="00000455"/>
3	26 Bits <input type="button" value="v"/>	<input type="text"/>
4	26 Bits <input type="button" value="v"/>	<input type="text"/>
5	26 Bits <input type="button" value="v"/>	<input type="text"/>
6	26 Bits <input type="button" value="v"/>	<input type="text"/>
7	26 Bits <input type="button" value="v"/>	<input type="text"/>
8	26 Bits <input type="button" value="v"/>	<input type="text"/>
9	26 Bits <input type="button" value="v"/>	<input type="text"/>
10	26 Bits <input type="button" value="v"/>	<input type="text"/>

*Figure 9-21*

## 9.3 Extended Device

You can define the GV-Readers and GV-GF Fingerprint Readers connected to GV-AS / GV-EV Controller through RS-485 or network connection. For GV-AS400, you can set up the GV-I/O Box connected.

**Note:**



1. GV-I/O Box is only supported for GV-AS400.
2. The Tailgating Setting page is currently not functional.

### 9.3.1 Extended Reader

In the left menu, click **Extended Reader**. This page appears.

**AS210 Extended Reader Configuration**

**GV-Reader/CR420/GF1921/GF1922 Function**

RS485	Serial Number	Function	Connection Status
<input type="checkbox"/>	ID 0 0013E2FF0A7C	Door/Gate 1 Entry	
<input type="checkbox"/>	ID 1 0013E2FF0A7D	Door/Gate 1 Exit	
<input checked="" type="checkbox"/>	ID 2 000012212612	Door/Gate 1 Entry	
<input type="checkbox"/>	ID 3	No Function	
<input type="checkbox"/>	ID 4	No Function	
<input type="checkbox"/>	ID 5	No Function	
<input type="checkbox"/>	ID 6	No Function	
<input type="checkbox"/>	ID 7	No Function	

GeoFinger Server IP Address  .  .  .  :  (from 1025 to 65535)

**GF1901/GF1902/GF1911/GF1912 Function**

RS485	Serial Number	Function	Connection Status
<input type="checkbox"/>		No Function	
<input type="checkbox"/>		No Function	
<input type="checkbox"/>		No Function	
<input type="checkbox"/>		No Function	
<input type="checkbox"/>		No Function	
<input type="checkbox"/>		No Function	
<input type="checkbox"/>		No Function	
<input type="checkbox"/>		No Function	

Figure 9-22

**[GV-Reader / CR420 / GF1921 / 1922 Function]** Define the readers connected to the controller, and then use the **Function** drop-down list to select the door associated with the reader.

- **GV-RK1352 / R1352 / DFR1352:** Select the **RS-485** checkbox and type the **Serial Number** of the reader. Note that the ID number located next to the serial number field need to match the reader's ID number defined through the GV-RK1352 Config AP.
- **GV-Reader 1251 / Reader 1352 V2:** Select the **RS-485** checkbox and leave the serial number field blank. Note that the ID number located next to the serial number field need to match the reader's ID number defined by the dip switches on the reader.
- **GV-GF1921 / GF1922:** Type the **MAC address** of the fingerprint reader and do not select the RS-485 checkbox.
- **GV-CR420:** Select the **RS-485** checkbox only if the GV-CR420 is connected to the controller through RS-485 connection. If the reader is using network connection, do not check the RS485 box. Type the **MAC address** of GV-CR420 if you using the latest GV-CR420 firmware. Refer to the note below if you are using firmware V1.0.

**GeoFinger Server IP Address:** To allow GV-ASManager to receive data from the GV-GF1921 / 1922 defined on this page during remote fingerprint enrollment, type the IP address and port of the GV-ASManager's GeoFinger Server. You can also complete this step on the Web interface of each GV-GF1921 / 1922 individually as shown below.

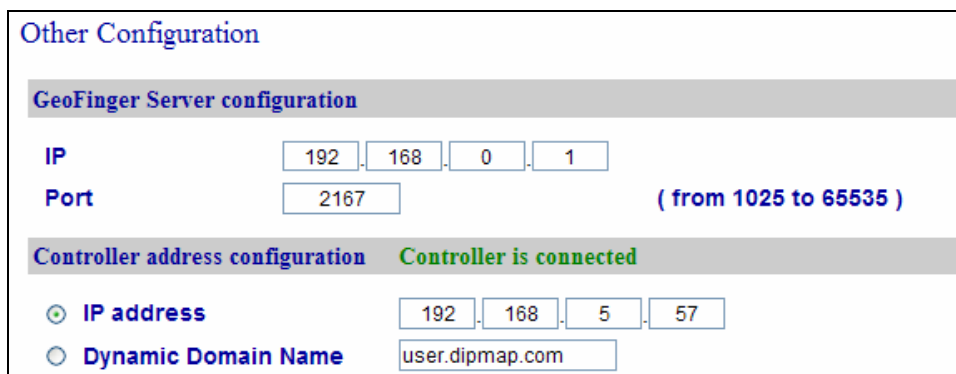

The screenshot shows a web interface titled "Other Configuration". Under the "GeoFinger Server configuration" section, there are two rows: "IP" with four input boxes containing "192", "168", "0", and "1"; and "Port" with one input box containing "2167" and a note "( from 1025 to 65535 )". Below this is the "Controller address configuration" section, which has a green status indicator "Controller is connected". It contains two rows: "IP address" with four input boxes containing "192", "168", "5", and "57"; and "Dynamic Domain Name" with one input box containing "user.dipmap.com".

Figure 9-23

**Note:**

1. To allow network connection, you must also enable network connection to the controller on the Web interface of the GV-CR420 or GV-GF1921 / 1922.
2. Refer to the table for connecting GV-CR420 and GV-AS Controllers through network.

	CR420 V1.0	CR420 V1.01
GV-AS210 / 410 / 810 V1.1 or later GV-EV48 V1.0 or later	Not Supported	MAC Address
GV-AS210 / 810 V1.0 GV-AS100 / 110 / 120 with ASBox / ASNet GV-AS400	Barcode	Not Supported

**[GF1901 / GF1902 / GF1911 / GF1912 Function]** Define the GV-GF1901 / 1902 / 1911 / 1912 connected to the controller.

- **GV-GF1901 / GF1902:** Select the **RS-485** checkbox and type the **XID Number** located on the back of the reader.
- **GV-GF1911 / GF1912:** Select the **RS-485** checkbox only if the GV-GF1911 / 1912 is connected to the controller through RS-485 connection. If the reader is using network connection, do not check the RS485 box. Type the **XID Number** located on the back of the reader.

Click **Submit** to detect the readers. If the reader is detected, the **Connection Status** field will be green.

### 9.3.2 Extended I/O

In the left menu, click **Extended I/O**. The **Extended I/O Configuration** page appears. The page defines the inputs and outputs on the GV-I/O Box which is connected to GV-AS400. The options in this page are the same as those mentioned in Input Setting and Output Setting pages.

---

**Note:** The Extended I/O setting page is only available for GV-AS400.

---

AS400 Extend IO 2 Configuration

**Input Function**

Input	Mode	Latch Enable
01	NO <span style="font-size: small;">v</span>	<input type="checkbox"/>
02	NO <span style="font-size: small;">v</span>	<input type="checkbox"/>
03	NO <span style="font-size: small;">v</span>	<input type="checkbox"/>
04	NO <span style="font-size: small;">v</span>	<input type="checkbox"/>

**Output Function**

Output	Mode	=	Trigger 1	AND	Trigger 2	AND	Trigger 3	AND	Trigger 4	
01	1)Normal N/O <span style="font-size: small;">v</span> 0 Sec	=	None <span style="font-size: small;">v</span> <span style="font-size: small;">v</span>	AND <span style="font-size: small;">v</span>	None <span style="font-size: small;">v</span> <span style="font-size: small;">v</span>	AND <span style="font-size: small;">v</span>	None <span style="font-size: small;">v</span> <span style="font-size: small;">v</span>	AND <span style="font-size: small;">v</span>	None <span style="font-size: small;">v</span> <span style="font-size: small;">v</span>	Reset
02	1)Normal N/O <span style="font-size: small;">v</span> 0 Sec	=	None <span style="font-size: small;">v</span> <span style="font-size: small;">v</span>	AND <span style="font-size: small;">v</span>	None <span style="font-size: small;">v</span> <span style="font-size: small;">v</span>	AND <span style="font-size: small;">v</span>	None <span style="font-size: small;">v</span> <span style="font-size: small;">v</span>	AND <span style="font-size: small;">v</span>	None <span style="font-size: small;">v</span> <span style="font-size: small;">v</span>	Reset
03	1)Normal N/O <span style="font-size: small;">v</span> 0 Sec	=	None <span style="font-size: small;">v</span> <span style="font-size: small;">v</span>	AND <span style="font-size: small;">v</span>	None <span style="font-size: small;">v</span> <span style="font-size: small;">v</span>	AND <span style="font-size: small;">v</span>	None <span style="font-size: small;">v</span> <span style="font-size: small;">v</span>	AND <span style="font-size: small;">v</span>	None <span style="font-size: small;">v</span> <span style="font-size: small;">v</span>	Reset
04	1)Normal N/O <span style="font-size: small;">v</span> 0 Sec	=	None <span style="font-size: small;">v</span> <span style="font-size: small;">v</span>	AND <span style="font-size: small;">v</span>	None <span style="font-size: small;">v</span> <span style="font-size: small;">v</span>	AND <span style="font-size: small;">v</span>	None <span style="font-size: small;">v</span> <span style="font-size: small;">v</span>	AND <span style="font-size: small;">v</span>	None <span style="font-size: small;">v</span> <span style="font-size: small;">v</span>	Reset

Figure 9-24

## **10. Optional Devices**

## 10.1 Optional GV-ASBox

The optional GV-ASBox is the I/O and network expansion module for GV-AS100, GV-AS110 and GV-AS120. With the GV-ASBox, additional network connectivity, 8 inputs, 8 outputs and 1 Wiegand reader can be added to GV-AS100, GV-AS110 or GV-AS120.

### 10.1.1 Main Features

- Add TCP/IP networking capability to GV-AS100 / 110 / 120
- Extend GV-AS100 / 110 / 120 from 1-door to 2-door controller
- Support 1 Wiegand reader of 26 to 64 bits
- Support 8 digital inputs and 8 relay outputs
- 4 special outputs for lighting control and energy saving
- Access GV-AS100 / 110 / 120's features through Web-based interfaces
- Route digital I/O controls from GV-AS100 / 110 / 120 to avoid tamper and enhance security level
- Support 4 units of GV-Readers and GV-GF Fingerprint Readers

### 10.1.2 Packing List

- GV-ASBox
- Power Adaptor 12V DC
- Power Cord
- Battery power cable



### 10.1.3 GV-ASBox Board Layout

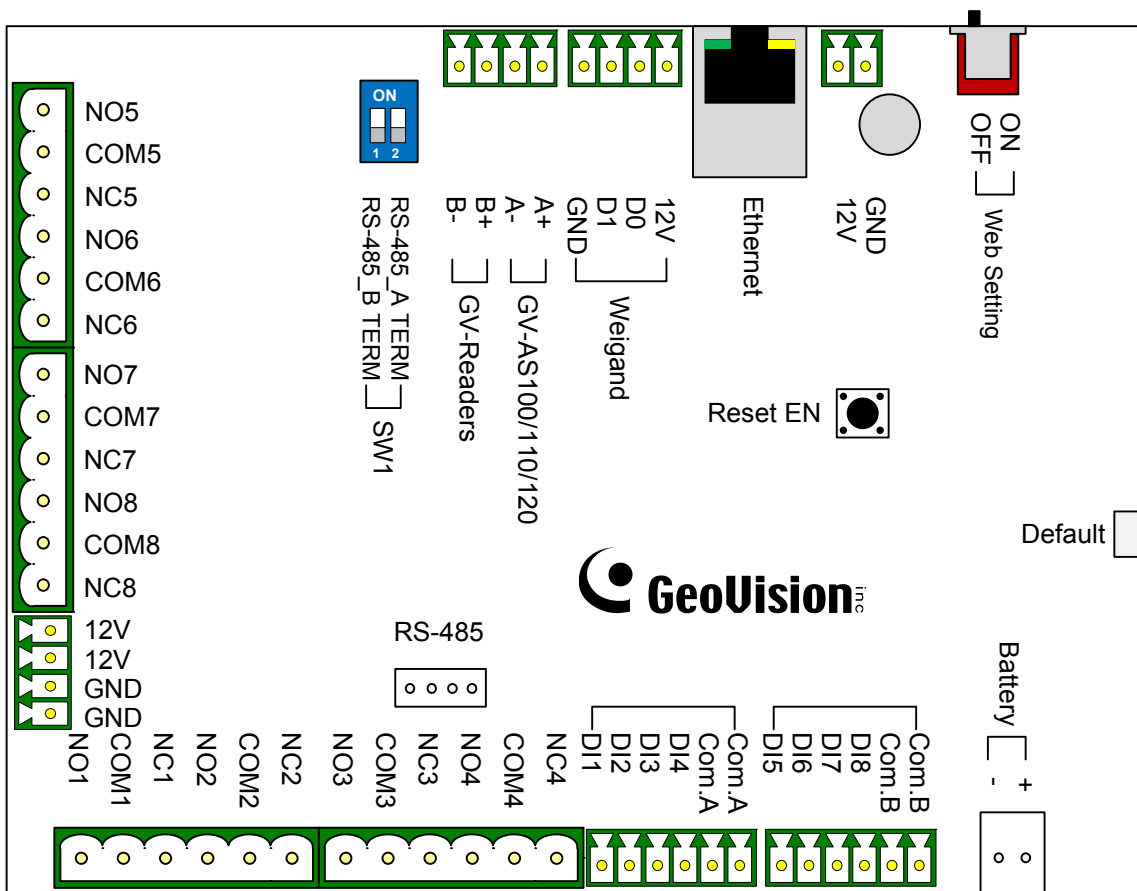

Figure 10-1

## 10.1.4 Installation

This section describes how to connect other devices to GV-ASBox.

### 10.1.4.A Connecting GV-AS100 / 110 / 120

The table and figure below show the pin assignments of related connectors on GV-ASBox for connection to GV-AS100, GV-AS110 and GV-AS120.

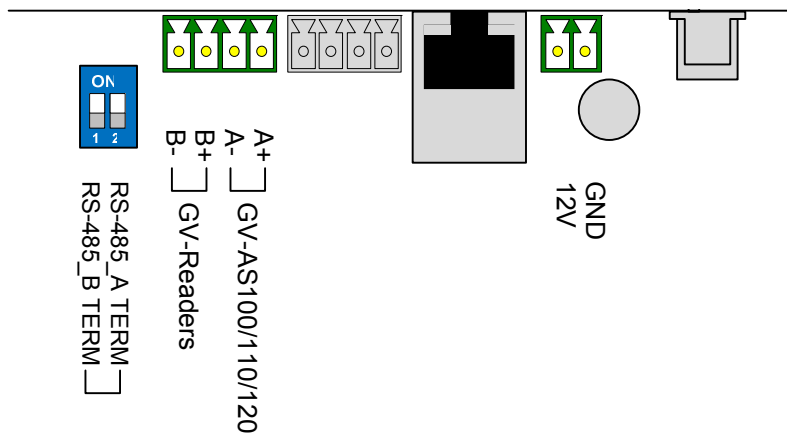

Figure 10-2

Pin	Function	Pin	Function	Pin	Function
12V	12V Power Supply to GV-AS100/110/120	A+	GV-AS100/110/120 Connection	B+	GV-Readers Connection
GND	GND for Power Supply to GV-AS100/110/120	A-	GV-AS100/110/120 Connection	B-	GV-Readers Connection

#### Note:

1. By default, **RS-485\_A Term** and **RS-485\_B Term** are set to OFF.
2. When the distance between the GV-ASBox and the GV-AS100 / 110 / 120 is over 600 meters, **RS-485\_A Term** must be switched to ON. When the distance between the GV-ASBox and the GV-Readers is over 600 meters, **RS-485\_B Term** must be switched to ON.

### 10.1.4.B Connecting a Wiegand Reader

GV-ASBox provides one Wiegand input for connection of the Wiegand-compatible reader ranging from 26 to 64 bits. The connected Wiegand reader can either work with GV-AS100 /GV-AS110/GV-AS120 to carry out entry and exit applications on a single door, or be installed on another door for the two-door application.

The table below shows the pin assignments of the Wiegand input on GV-ASBox. Please consult the documentation of your Wiegand reader for wiring.

Pin	Function
GND	GND for the Power Supply
D0	Wiegand Data 0
D1	Wiegand Data 1
12V	12V Power Supply

To define the reader, you need to use the GV-AS100/GV-AS110/GV-AS120 Web interface. See *10.3.2.B Parameter Setting*.

### 10.1.4.C Connecting GV-Readers and GV-GF Fingerprint Readers

You can connect up to **4 units of GV-Readers and GV-GF Fingerprint Readers** to GV-ASBox. Multiple GV-Readers and GV-GF Fingerprint Readers can be connected with a single RS-485 cable to separate RS-485 interfaces on GV-ASBox.

Since Wiegand communication distance is shorter than RS-485's, you can choose GV-Reader and GV-GF Fingerprint Reader supporting RS-485 communication to add another door control and meet the need of long-distance installation.

Use the RS-485 B+ B- to connect to GV-Readers and use the RS-485 interface to connect GV-GF Fingerprint Readers. Refer to the figure below to see where the RS-485 interfaces are located. When multiple readers are connected together, an extra power supply to each unit is required. Use the auxiliary power output of **12V** and **GND** on GV-ASBox to power on each unit.

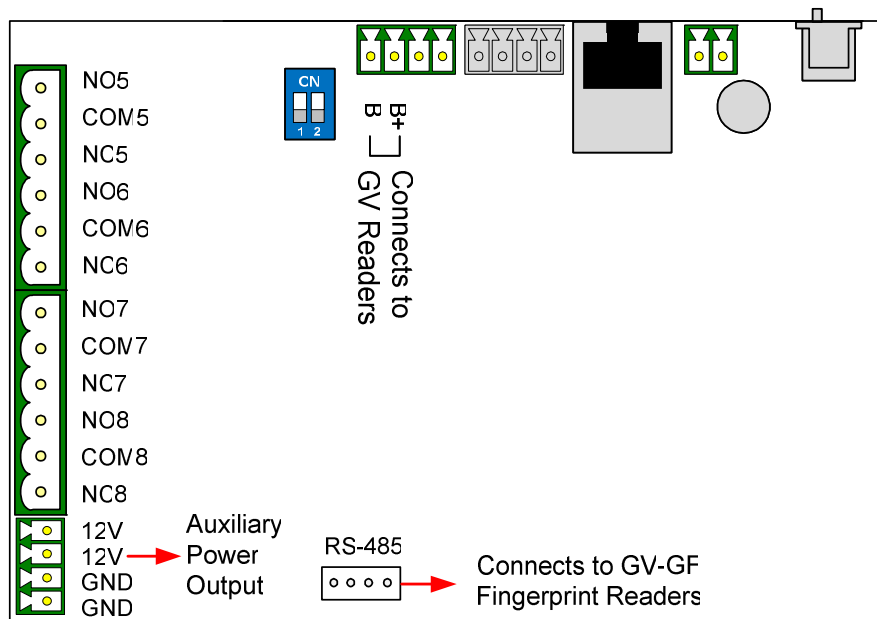

Figure 10-3

To define each GV-Reader and GV-GF Fingerprint Reader, you need to use the GV-AS100/GV-AS110/GV-AS120 Web interface. See *10.3.2.G Extended Reader Setting*.

---

**Note:** The RS-485 connector on GV-ASBox is only designed for the connection of GV-Readers and GV-GF Fingerprint Readers.

---

### 10.1.4.D Connecting Input Devices

GV-ASBox provides 8 inputs (DI1 to DI8). All inputs are **dry contact** and can be configured as normally open (NO) or normally closed (NC) through the Web interface. The default value is **NO**.

The figure below shows the pin assignments of input connectors on GV-ASBox. The 8 inputs are divided into two terminals. Terminal A consists of DI1 to DI4, and terminal B includes DI5 to DI8. Every terminal has two COM (Common) points; connect the Common wire to any of the two COM points on the related terminal.

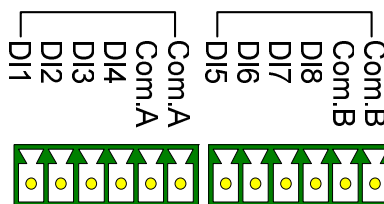

Figure 10-4

### 10.1.4.E Connecting Output Devices

GV-ASBox provides 8 outputs and 2 auxiliary power outputs of 12V DC. The outputs are divided into two groups, **outputs 1 ~ 4** and **outputs 5 ~ 8**. Before connecting, make sure if your output device meets any of the two different absolute maximum ratings listed below.

Additionally, you can **wire the light switch to the outputs 5 ~ 8** for lighting control. When the access is granted, the light is turned on; when the exit is granted, the light is turned off. See *To combine door access with relay activation* below.

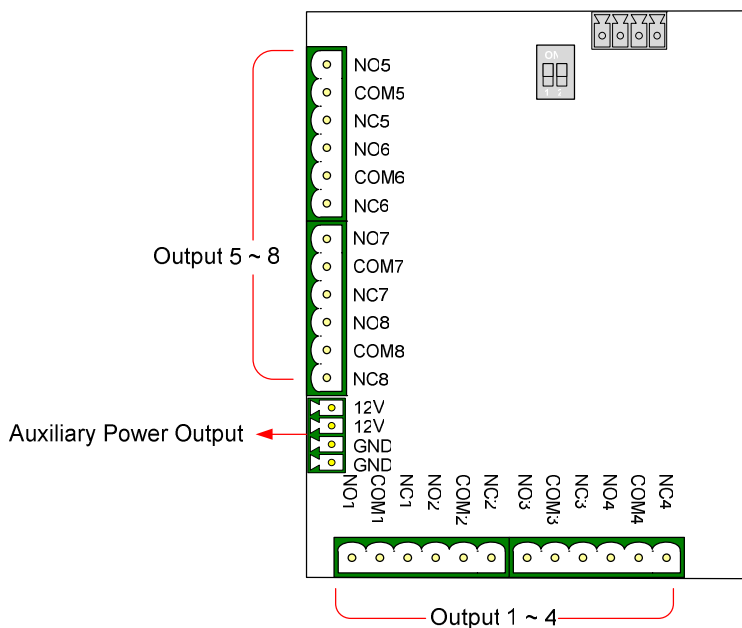

Figure 10-5

#### Outputs 1-4: Absolute Maximum Ratings

<b>Breakdown Voltage</b>	277V AC, 30V DC
<b>Continuous Load Current</b>	5A (NO), 3A (NC)
<b>Note:</b> Absolute Maximum Ratings are those values beyond which damage to GV-ASBox circuit board may occur. Continuous operation of GV-ASBox at the absolute rating level may affect GV-ASBox reliability.	

#### Outputs 5-8: Absolute Maximum Ratings

<b>Breakdown Voltage</b>	240V AC, 30V DC
<b>Continuous Load Current</b>	16A (NO), 8A (NC)
<b>Note:</b> Absolute Maximum Ratings are those values beyond which damage to GV-ASBox circuit board may occur. Continuous operation of GV-ASBox at the absolute rating level may affect GV-ASBox reliability.	

**To connect an output device:**

GV-ASBox provides two auxiliary power outputs of 12V DC at a maximum current of 1A. If your output device requires higher current, you must have the power supplied from an external power supply. Connect the (+) point on the output device to COM on GV-ASBox, connect the (-) points on the output device and the external power supply together, and connect the (+) point on the external power supply to the NO or NC of GV-ASBox based on the state of the output device.

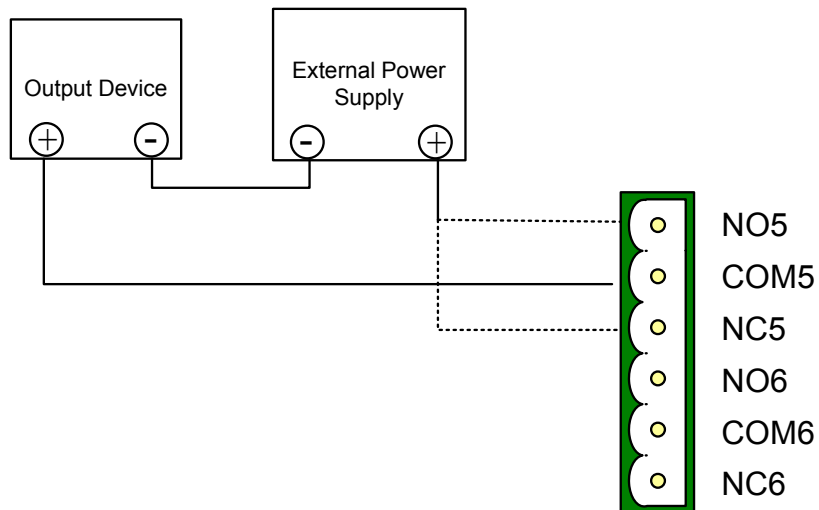

Figure 10-6

**To combine door access with relay activation:**

You can combine door access with relay activation for light control, machine control, etc., so that these will only be active when access is granted. For example, the light is turned on when a user is granted access to a room; the light is turned off when the user exits from the room. For this function, wire the relay switch to **output 5 ~ 8**.

### 10.1.4.F Connecting Backup Battery

You can connect any battery of 12V 12Ah to GV-ASBox to provide backup power when the main power supply fails. When the main power supply is removed and the battery voltage level is above 10.2V, the battery will support normal operation of the GV-ASBox.

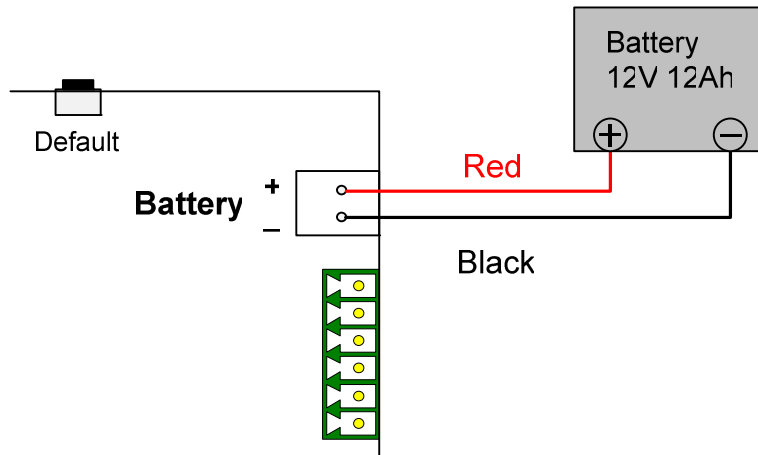

Figure 10-7



### 10.1.4.G Other Settings

The figure below shows the location of the **Web Setting Switch**, **Reset Button** and **Default Button**.

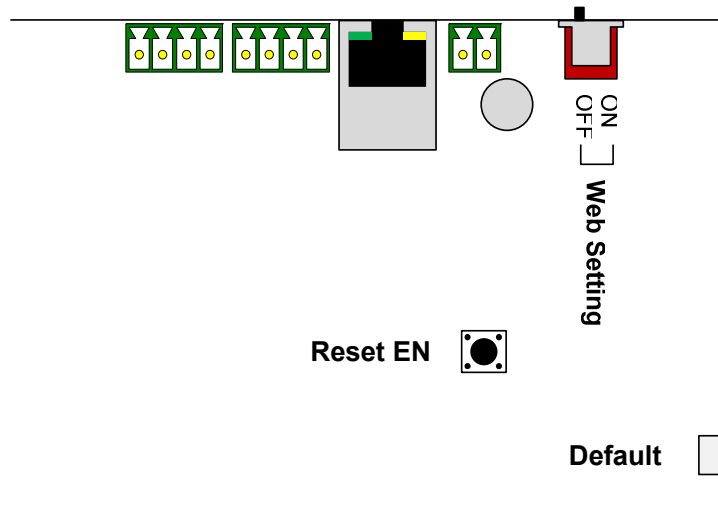

Figure 10-8

#### 10.1.4.G.a Web Setting Switch

When the **Web Setting** switch is set to ON, you can modify **Advanced Settings** of GV-AS100, GV-AS110 and GV-AS120 through the Web interface. When the switch is set to OFF, Advanced Settings are not accessible. For details on Advanced Settings, see *10.3.2 Advanced Settings*.

#### 10.1.4.G.b Resetting the GV-ASBox

To reset GV-ASBox, press the **Reset EN** button on GV-ASBox for 3 seconds.

#### 10.1.4.G.c Restoring Factory Defaults

To restore factory default values, press the Default button on GV-ASBox for 3 seconds. After this it may take up to 3 minutes to restore GV-ASBox to default values.

## 10.1.5 GV-ASBox Specifications

CPU		32-bit ARM7TDMI Microprocessor
Power		100 ~ 240V AC, 50 ~ 60Hz
Battery		12V, 5Ah
RS-485 Interface		2 separate interfaces for GV-Readers and GV-GF Fingerprint Readers (Max. 4 readers)
Wiegand Interface		1 Wiegand interface, 26 ~ 64 bit format
		12V DC Power Supply, 200mA
Communication Protocol	GV-AS100/110/120	RS-485
	GV-ASManager	TCP/IP (10/100 Mbps Ethernet)
Digital I/O	Input	8 inputs, dry contact, NO / NC
	Output	8 outputs
Operating Temperature		0 ~ 65°C / 32 ~ 149°F
Operating Humidity		10% ~ 90% RH (non-condensing)
Board Dimensions (W X H X D)		214 x 206 x 48.5 mm / 8.43 x 8.11 x 1.91 in
Weight		850 g / 1.83 lb
Certification		CE, FCC, RoHS

All specifications are subject to change without notice.

## 10.2 Optional GV-ASNet

The optional GV-ASNet is the network expansion module for GV-AS100, GV-AS110 and GV-AS120. With the GV-ASNet, GV-AS100 / 110 / 120 can be connected to the GV-ASManager and you can access the Web interface of GV-AS100 / 110 / 120.

### 10.2.1 Main Features

- Add TCP/IP networking capability to GV-AS100 / 110 / 120
- Access GV-AS100 / 110 / 120's features through Web-based interfaces
- Support 2 units of GV-Readers and GV-GF Fingerprint Readers

### 10.2.2 Packing List

- GV-ASNet
- Power Adaptor 12V DC
- Power Cord
- Battery Power Cable

## 10.2.3 GV-ASNet Overview

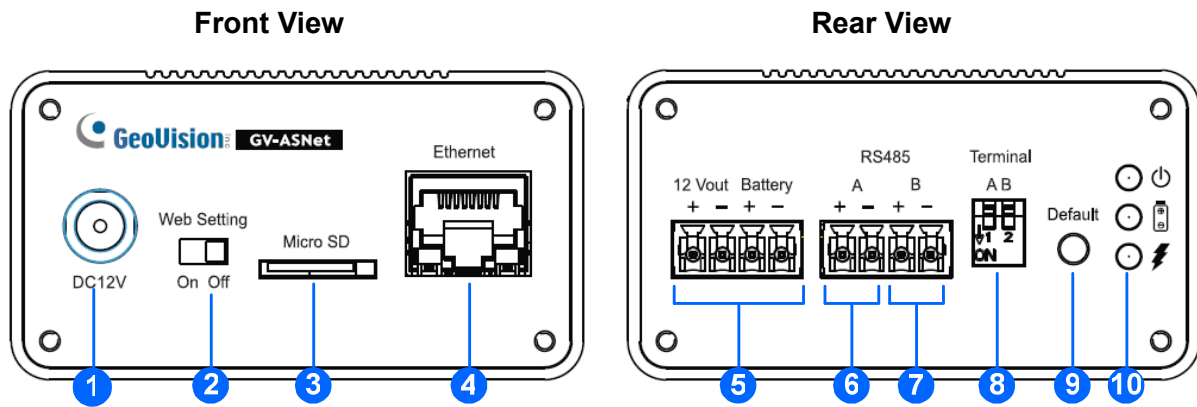

Figure 10-9

No.	Name	Function
1	DC Power Input (12V)	Connects to power supply.
2	Web Setting	Enables the Advanced Settings on Web interface of GV-AS100/GV-AS110/GV-AS120.
3	Micro SD	The Micro SD slot is not functional at this point.
4	Ethernet	Connects to the network.
5	12V+/12V- Battery	Power supply for GV-AS100/GV-AS110/GV-AS120.
6	RS485A+/RS485A-	Connects to GV-AS100/GV-AS110/GV-AS120.
7	RS485B+/RS485B-	Connects to GV-Readers.
8	Terminal A/B	Enables RS-485 interface.
9	Default button	Resets all configurations to factory defaults.
10	Power LED	Shows the power source and battery charging status of the GV-ASNet. See 9.2.4.C Other Settings for more details.

## 10.2.4 Installation

This section describes how to connect other devices to GV-ASNet.

### 10.2.4.A Connecting GV-AS100 / 110 / 120

The table and figure below show the pin assignments of related connectors on the rear view of the GV-ASNet for connection to GV-AS100 / 110 / 120.

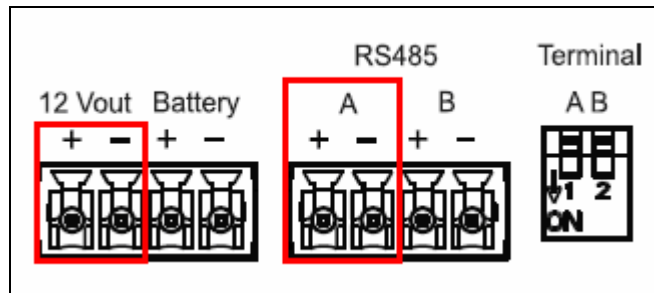

Figure 10-10

Pin	Function	Pin	Function
12V+	12V Power Supply to GV-AS100 / 110 /120	12V-	GND for Power Supply to GV-AS100 / 110 / 120
RS485A+	GV-AS100 / 110 / 120 Connection	RS485A-	GV-AS100 / 110 / 120 Connection

**Note:**

1. By default, **RS-485\_A Term** and **RS-485\_B Term** are set to OFF.
2. When the distance between the GV-ASNet and the GV-AS100 / 110 / 120 is over 600 meters, **RS-485\_A Term** must be switched to ON. When the distance between the GV-ASNet and the GV-Readers is over 600 meters, **RS-485\_B Term** must be switched to ON.

### 10.2.4.B Connecting GV-Readers and GV-GF Fingerprint Readers

You can connect up to **2 units of GV-Readers and GV-GF Fingerprint Readers** to GV-ASNet. Multiple GV-Readers and GV-GF Fingerprint Readers can be connected with a single RS-485 cable to the RS485 B+ and B- on GV-ASNet. You will need to connect the GV-Readers or GV-GF Fingerprint Readers to external power supply.

The figure and table shows the pin assignments for related connectors.

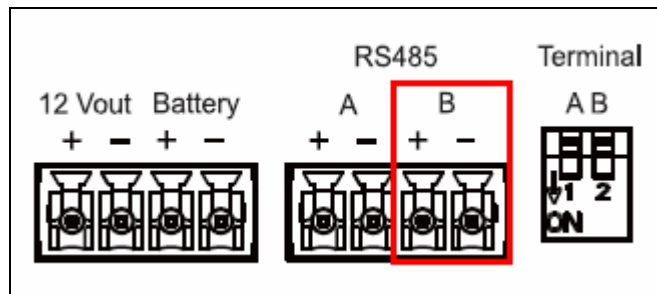

Figure 10-11

Pin	Function	Pin	Function
RS485B+	GV-Reader / GV-GF Fingerprint Readers Connection	RS485B-	GV-Reader / GV-GF Fingerprint Readers Connection

To define each GV-Reader and GV-GF Fingerprint Reader, you need to use the GV-AS100 / 110 / 120 Web interface. See *10.3.2.G Extended Reader*.

### 10.2.4.C Connecting Backup Battery

You can connect any battery of 12V 12Ah to GV-ASNet to provide backup power when the main power supply fails. When the main power supply is removed and the battery voltage level is above 10.2V, the battery will support normal operation of the GV-ASNet.

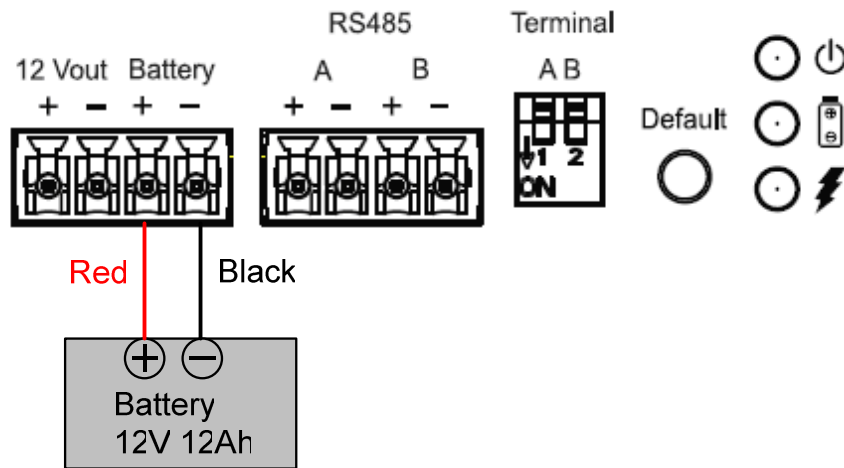

Figure 10-12

### 10.2.4.D Other Settings

The figure below shows the location of the **Web Setting Switch**, **Default Button** and **Power Status LED**.

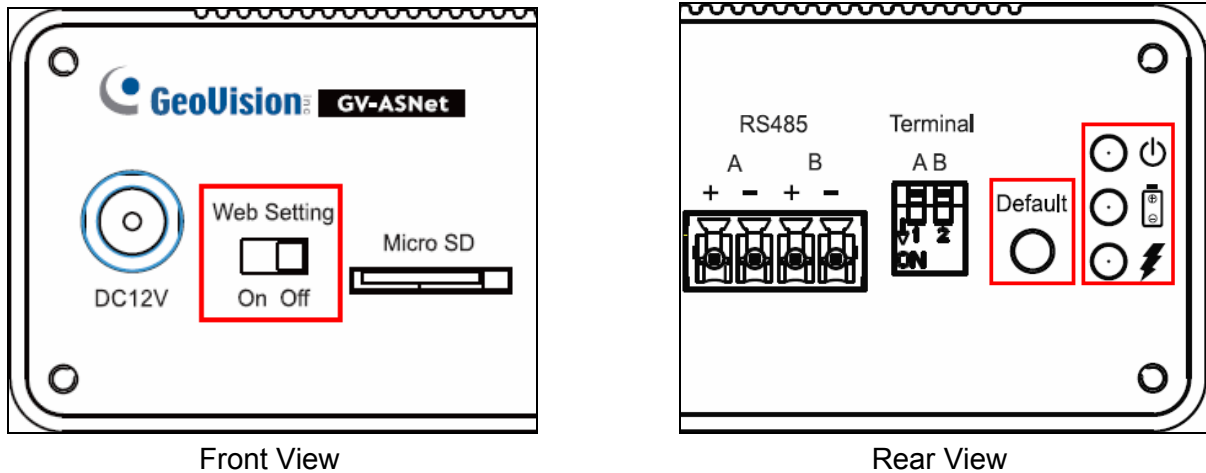

Figure 10-13



#### 10.2.4.D.a Web Setting Switch

When the **Web Setting** switch is set to ON, you can modify **Advanced Settings** of GV-AS100 / 110 / 120 through the Web interface. When the switch is set to OFF, Advanced Settings are not accessible. For details on Advanced Settings, see *10.3.2 Advanced Settings*.

#### 10.2.4.D.b Restoring Factory Defaults

To restore factory default values, press the Default button on GV-ASNet for 6 seconds. After this it may take up to 3 minutes to restore GV-ASNet to default values.

#### 10.2.4.D.c Power Status LED

The three LED located on the right of the rear panel indicate the power status of the GV-ASNet. When the power LED  is red, it indicates that the GV-ASNet is powered. When the main power source is off and that the GV-ASNet is running on battery, the battery LED  turns green. An orange charging LED  means that the battery is being charged.



## 10.2.5 GV-ASNet Specifications

CPU	32-bit ARM7TDMI Microprocessor	
Power	100 ~ 240V AC, 50 ~ 60Hz	
Battery	12V, 5Ah and 12V, 12Ah	
RS-485 Interface	1 RS-485 interface only for GV-Readers and GV-GF Fingerprint Readers (Max. 2 readers)	
Communication Protocol	GV-AS100/110/120	RS-485
	GV-ASManager	TCP/IP (10/100 Mbps Ethernet)
Operating Temperature	0 ~ 65°C / 32 ~ 149°F	
Operating Humidity	10% ~ 90% RH (non-condensing)	
Dimensions (W X H X D)	118.3 x 74 x 40 mm / 4.7 x 2.9 x 1.6 in	
Weight	300 g / 0.66 lb	
Certification	CE, FCC, RoHS	

All specifications are subject to change without notice.

## 10.3 Web Interface through Optional Devices

Through GV-ASBox or GV-ASNet, you can access the GV-AS100 / GV-AS110 / GV-AS120's Web interface. Also through GV-ASBox or GV-ASNet, GV-AS100, GV-AS110 or GV-AS120 can communicate with GV-ASManager over the network.

GV-ASBox and GV-ASNet must be assigned an IP address to make it accessible on the network. Refer to *Chapter 8 Installing on a Network* for detailed instructions.

The Web interface is divided into three sections: **Basic Setting**, **Advanced Setting** and **Extended Device**.

### 10.3.1 Basic Setting

The Basic Setting section consists of four setup pages:

Category	Setting	Description
<b>Basic Setting</b>	Network Setting	There are different methods to install GV-ASBox and GV-ASNet on the network. See <i>Chapter 8 Installing on a Network</i> .
	Other Setting	See <i>9.1.1 System Setup</i> .
	Firmware Upgrade	See <i>9.1.2 Upgrading Firmware</i> .
	Account Setting	See <i>9.1.3 Changing Login ID and Password</i> .

## 10.3.2 Advanced Settings

You can execute and edit door/Wiegand operations and settings, turn on Alarms, view status, display card information stored in GV-AS100 / 110 / 120, set the device time and edit the input/output functions.

The changes in some of the Advanced Setting page will effect the options available on other pages. The diagram below shows the relationships between each Advanced Setting page.

**The Relationship Diagram between each Advanced Setting Page**

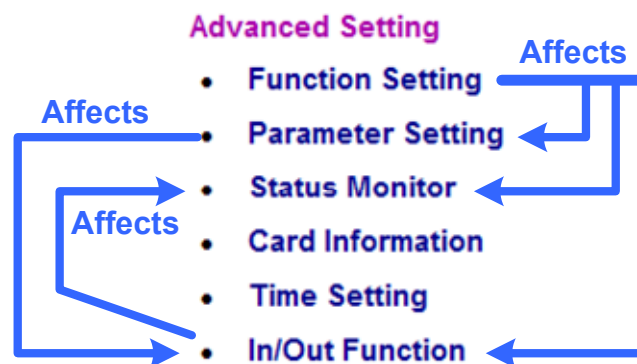

Figure 10-14

---

**Note:** The Status Monitor and In/Out Function pages are only available when connecting through a GV-ASBox.

---

### 10.3.2.A Function Setting

In the left menu, click **Function Setting**. This **AS100/AS110/AS120 Function Configuration** page appears.

**Note:** The Wiegand settings and Door/Gate B settings are only available when connecting through GV-ASBox.

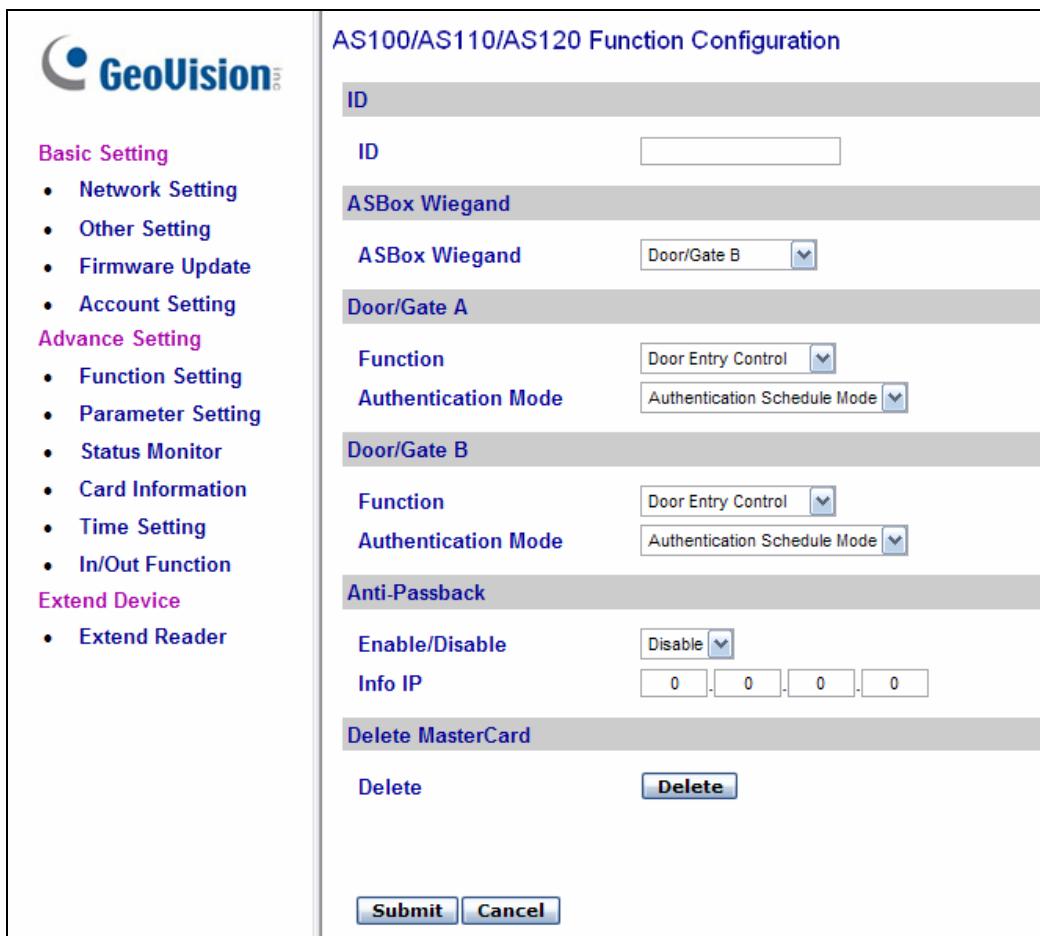

Figure 10-15

#### [ID]

Enter the ID number for GV-AS100, GV-AS110 or GV-AS120. This ID is used by GV-ASManager to differentiate among multiple units of GV-AS100 / 110 / 120. ID number can only be between 1 and 255.

**[ASBox Wiegand]**

This option is only available for GV-ASBox. Select the function for Wiegand Input on GV-ASBox from the drop-down list.

- **No Function:** Wiegand Input is not in use.
- **Door/Gate A Entry:** Wiegand Input becomes the entry point for Door/Gate A.
- **Door/Gate A Exit:** Wiegand Input becomes the exit point for Door/Gate A.
- **Door/Gate B:** Wiegand Input becomes Door/Gate B.

**[Door/Gate A]**

Select the function type and authentication mode for the use of Door/Gate A.

- **Function:** Select the function for GV-AS100 / 110 / 120 on Door/Gate A.
  - ⊙ **Door Entry Control:** Sets GV-AS100 / 110 / 120 as entry reader on the Door A. The Wiegand reader connected on GV-AS100 / 110 / 120 will be set as exit reader.
  - ⊙ **Door Exit Control:** Sets GV-AS100 / 110 / 120 as exit reader on the Door A. The Wiegand reader connected on GV-AS100 / 110 / 120 will be set as entry reader.
  - ⊙ **Parking Entry Control:** Sets GV-AS100 / 110 / 120 as entry reader on the parking Gate A.
  - ⊙ **Parking Exit Control:** Sets GV-AS100 / 110 / 120 as exit reader on the parking Gate A.
  - ⊙ **Elevator Control:** GV-AS100 / 110 / 120 is installed in the elevator for access control.

---

**Note:** The **Parking Entry Control** and **Parking Exit Control** only work when the sensor input of Car Detection is activated. When the card is present but the sensor input is not activated, the message “No Car In Zone” will appear in the GV-AS100 LCD.

---

- **Authentication Mode:** Select the authentication mode for the Door/Gate A.
  - ⊙ **Local Unlock Mode:** Remains open. The held-open state cannot be cleared through GV-ASManager.
  - ⊙ **Local Lock Mode:** Remains locked. The locked state cannot be cleared through GV-ASManager.
  - ⊙ **Fixed Card Mode:** Grants access after the card is presented, and ignores the authentication schedule of GV-ASManager.

- ⊙ **Fixed Card + PIN Mode:** Grants access after the user presents the card and then enters the card's PIN code, and ignores the authentication schedule of GV-ASManager.
- ⊙ **Fixed Card/Common mode:** Grants access after the user presents the card or enters the door's password, and ignores the authentication schedule of GV-ASManager.
- ⊙ **Authentication Schedule Mode:** Follows the authentication schedule set on GV-ASManager.

### **[Door/Gate B]**

This option is only available for GV-ASBox and only becomes available after **Door/Gate B** is selected from the **ASBox Wiegand** option above.

Select the function type and authentication mode for the use of Door/Gate B. The Function and Authentication Mode options are the same as those of Door/Gate A. But remember that the settings here are used to define the Wiegand reader connected to GV-ASBox.

### **[Anti-Passback]**

This setting lets you perform Anti-Passback applications across multiple GV-AS Controllers. Anti-Passback prevents use of a card to gain successive entries without exit to a controlled area. For details on setup, see *Chapter 6 Anti-Passback on GV-ASManager User's Manual*.

- **Enable/Disable:** Enables or disables the Anti-Passback function.
- **Info IP:** Enter the IP address of the next corresponding GV-AS100 / 110 / 120.

### **[Delete MasterCard]**

- **Delete:** Click the **Delete** button to delete the current MasterCard information.

Click **Submit** button to save the changes, or click **Cancel** button to return the changes to its previous state.

### 10.3.2.B Parameter Setting

In the left menu, click **Parameter Setting**. This **AS100/AS110/AS120 Configuration** page appears. The contents of Parameter Setting change based on your settings for Door/Gate A and Door/Gate B in the **Function Setting** page (Figure 10-15).

**Note:** The Door B settings and Input Name settings are only available when connecting through GV-ASBox.

The screenshot shows the 'AS100/AS110/AS120 Configuration' page. On the left is a sidebar with the following menu items: Basic Setting (Network Setting, Other Setting, Firmware Update, Account Setting), Advance Setting (Function Setting, Parameter Setting, Status Monitor, Card Information, Time Setting, In/Out Function), and Extend Device (Extend Reader). The 'Parameter Setting' item is highlighted. The main content area is titled 'AS100/AS110/AS120 Configuration' and contains the following sections:

- Events:**
  - Door A: Anti-passback (NO), Lock Reset Time (5, 1~255), Held Open Time (5, 5~9999), Fire Action (Unchange), Alarm Continuous Time (5, 1~10).
  - Door B: Anti-passback (NO), Lock Reset Time (5, 1~255), Held Open Time (5, 5~9999), Fire Action (Unchange), Alarm Continuous Time (5, 1~10).
- Alarm:**
  - Door A: Held Open (NO), Forced Open (NO), Fire Alarm (NO), Access Denied (NO), Tamper (NO).
  - Door B: Held Open (NO), Forced Open (NO), Fire Alarm (NO), Access Denied (NO), Tamper (NO).
- Common Password:**
  - Door A: Common Password (masked), Password Confirm (masked).
  - Door B: Common Password (masked), Password Confirm (masked).
- AS100 Input Name:**
  - Input 1 Name: AS100 Input 1
  - Input 2 Name: AS100 Input 2
  - Input 3 Name: AS100 Input 3
  - Input 4 Name: AS100 Input 4

Figure 10-16

**IMPORTANT:** Once connecting to GV-AS100 / 110 / 120, GV-ASManager will load its parameters to the GV-AS Controller. That means some of the Parameter Settings you have configured here may be rewritten by GV-ASManager later.

## [Events]

Set the parameters for the events.

Events	
<b>Door A</b>	<b>Gate B</b>
Anti-passback	Gate Open Time
Lock Reset Time	Held Open Time
Held Open Time	Fire Action
Fire Action	Alarm Continuous Time
Alarm Continuous Time	

Figure 10-17

- When **Door Entry/Exit Control** or **Parking Entry/Exit Control** is selected in the **Function Setting** page (Figure 10-15), these options become available:

Option	Description
Anti-Passback	Enables or disables the Anti-Passback function. The option is only available for <b>Door/Gate A</b> .
Gate Open Time	Sets the time (1 to 255 sec.) that a parking gate remains open after which the gate will automatically be locked. The option is only available when <b>Parking Entry/Exit Control</b> is selected.
Lock Reset Time	Sets the time (1 to 255 sec.) that a door remains open after which the door will automatically be locked. The option is only available when <b>Door Entry/Exit Control</b> is selected.
Held Open Time	Sets the time (5 to 9999 sec.) that a door/gate can be held open before an alarm is generated.
Fire Action	Locks or unlocks the door/gate when a fire condition occurs. Otherwise, remains the door's current state by selecting <i>Unchanged</i> .
Alarm Continuous Time	Sets the time (1 to 10 sec.) that the alarm will continuously go off before it ends.

- When **Elevator Control** is selected in the **Function Setting** page (Figure 10-15), these options become available:

Option	Description
Relay on Time	Sets the time (1 to 255 sec.) that an elevator door remains open after which the door will automatically be closed.
Fire Action	See the same option above.
Alarm Continuous Time	



**[Alarm]**

Select **Yes** or **No** to enable or disable the alarm function. If you have defined the alarm conditions in [Output Function] of the **In/Out Function** page (Figure 10-23), remember to activate the corresponding alarms here; otherwise, even though the alarm conditions are met, the expected alarm will not be triggered. The default settings for all the alarms are set to **NO**.

Alarm			
<b>Door A</b>		<b>Gate B</b>	
Held Open	NO	Held Open	YES
Forced Open	NO	Forced Open	YES
Fire Alarm	YES	Fire Alarm	YES
Access Denied	YES	Access Denied	YES
Tamper	YES	Tamper	YES

Figure 10-18

- When **Door Entry/Exit Control** or **Parking Entry/Exit Control** is selected in the **Function Setting** page (Figure 10-15), these options become available:

Option	Description
Held Open	This alarm activates whenever the door is held open over the set period of time.
Forced Open	This alarm activates whenever the door is opened by force.
Fire Alarm	This alarm activates whenever fire is detected.
Access Denied	This alarm activates whenever entry is denied due to using the wrong card or entering the wrong password.
Tamper	This alarm activates whenever vandalism occurs, e.g. the opening of Controller’s cabinet.

- When **Elevator Control** is selected in the **Function Setting** page (Figure 10-15), these options become available:

Option	Description
Fire Alarm	See the same option above.
Access Denied	
Tamper	

### [Common Password]

When **Fixed Card/Common Mode** is selected as **Authentication Mode** in the **Function Setting** page (Figure 10-15), you can gain access by using the card or entering this Common Password (door's password).

Common Password			
<b>Door A</b>		<b>Gate B</b>	
<b>Common Password</b>	<input type="password"/>	<b>Common Password</b>	<input type="password"/>
<b>Password Confirm</b>	<input type="password"/>	<b>Password Confirm</b>	<input type="password"/>

Figure 10-19

### [AS100 Input Name]

This option is only available for GV-ASBox. Rename the input names by clicking **Submit** button to save the changes, or click **Cancel** button to return the changes to its previous state.

### 10.3.2.C Status Monitor

In the left menu, click **Status Monitor** to see the status of each input, output and alarm

**Note:** The Status Monitor page is only available when connecting through a GV-ASBox.

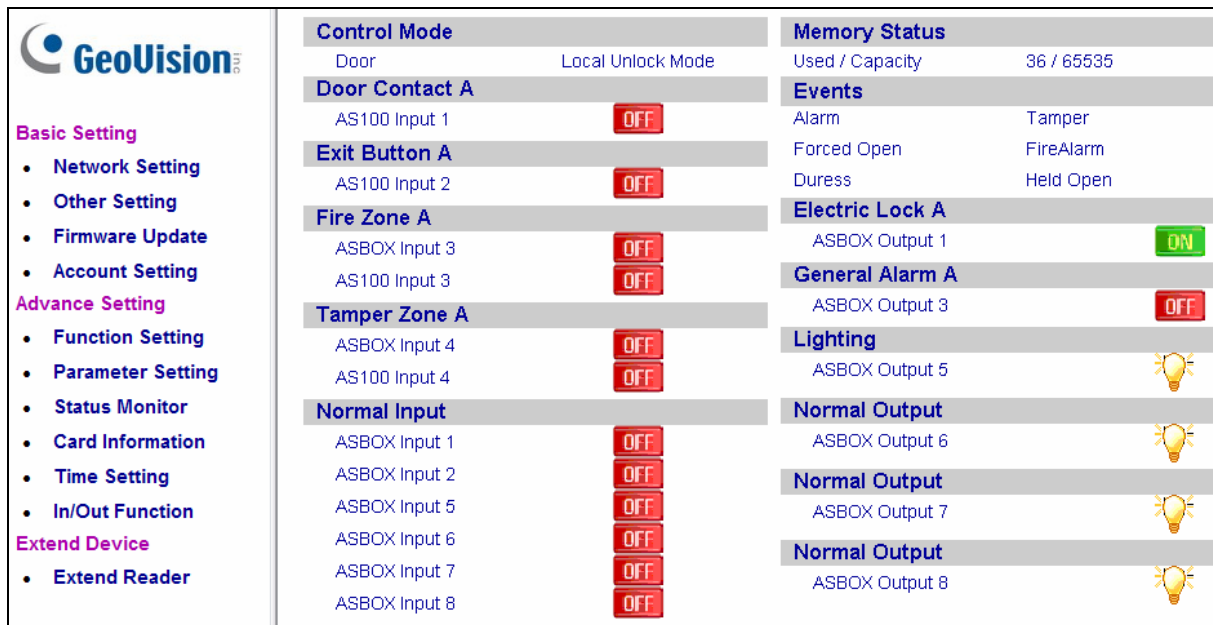

Figure 10-20

**Control Mode** will change depending on the chosen Door/Gate's **Authentication Mode** in the **Function Setting** page (Figure 10-15). The listed number of outputs will change depending on the chosen **Output Type** in the **In/Out Function** page (Figure 10-23).



= Indicates the current input/output device is triggered.



= Indicates the current input/output source is not triggered.



= Indicates the current event is triggered.



= Indicates the current light is on.



= Indicates the current light is off.

**Note:** Outputs must be turned on in the **In/Out Function** page to be monitored here.

### 10.3.2.D Card Information

In the left menu, click **Card Information**. This **Card Configuration** page appears.

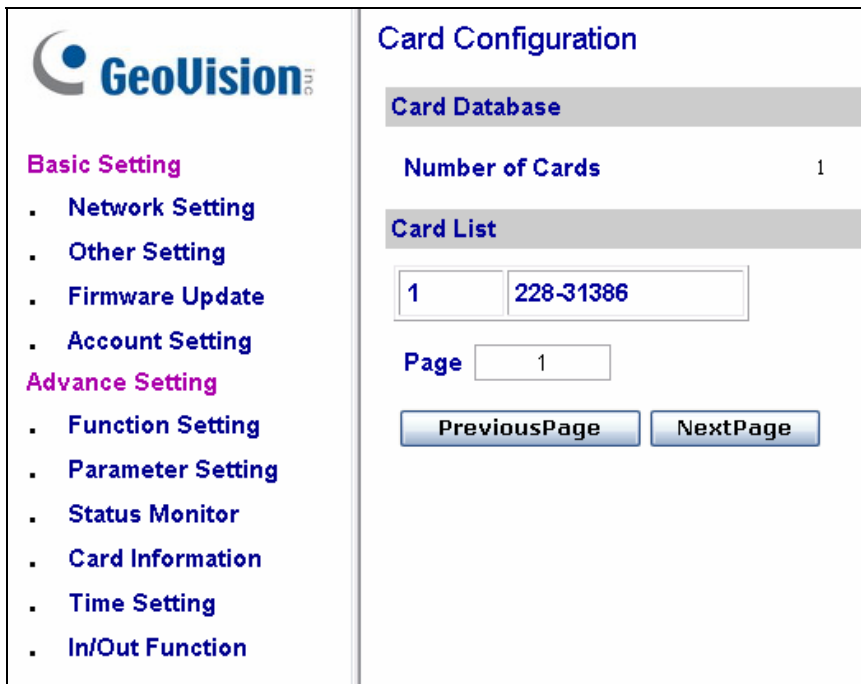

Figure 10-21

#### [Card Database]

Shows the number of cards currently stored in GV-AS100 / 110 / 120.

#### [Card List]

Displays the list of cards stored in GV-AS100 / 110 / 120. If there are many pages, you can choose to jump to any page by entering the page number in the **Page** field.

Click **Previous Page** button to go to the previous page of the Card List, or click **Next Page** button to go to the next page of the **Card List**.

### 10.3.2.E Time Setting

In the left menu, click **Time Setting**. This **Time Configuration** page appears.

Figure 10-22

#### [System Local Time]

- **Local Time:** Displays the current date and time of GV-AS100 / 110 / 120.
- **Time Zone:** Displays the current time zone of GV-AS100 / 110 / 120.

#### [Local Time]

- **Disable:** Disable the manual configuration of time and date.
- **Setup:** Enable the manual configuration of **Time Zone**, **Date** and **Time** for GV-AS100 / 110 / 120.

#### [Daylight Savings Time (DST)]

- **Disable:** Disable the manual configuration of DST.
- **Time Zone:** Enable the manual configuration of DST by setting the **Start Time** and **Stop Time** for the DST period.

Click **Submit** button to save the changes, or click **Cancel** button to return the changes to its previous state.

### 10.3.2.F In/Out Function

In the left menu, click **In/Out Function** to define the input and output sensors.

**Note:** The I/O Configuration page is only available when connecting through a GV-ASBox.

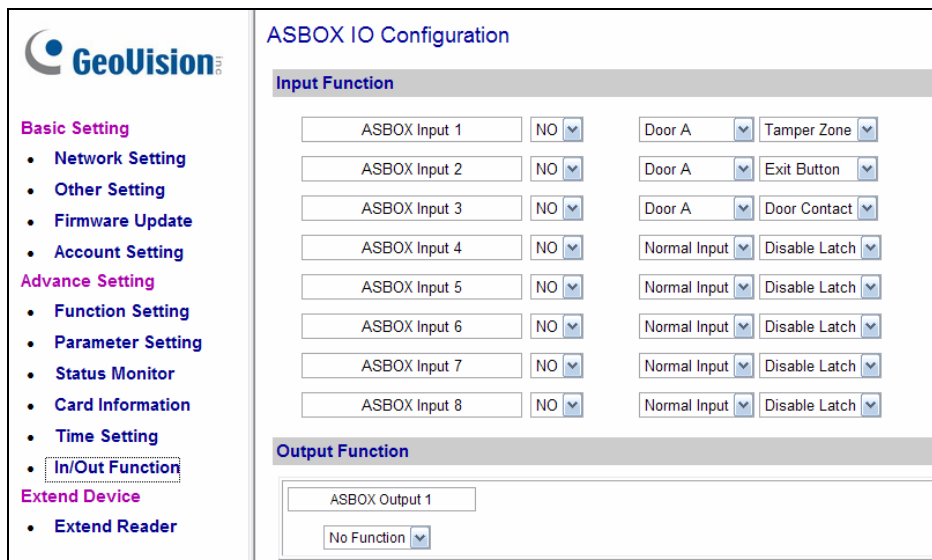

Figure 10-23

#### [Input Function]

Here you can define each sensor input that is connected GV-ASBox and select the most fitting **Input Type** (No. 3, Figure 10-24) and **Input Function** (No. 4, Figure 10-24) to describe the sensor input. Through the sensor input, an alarm event can be detected and it can then trigger the alarm device.

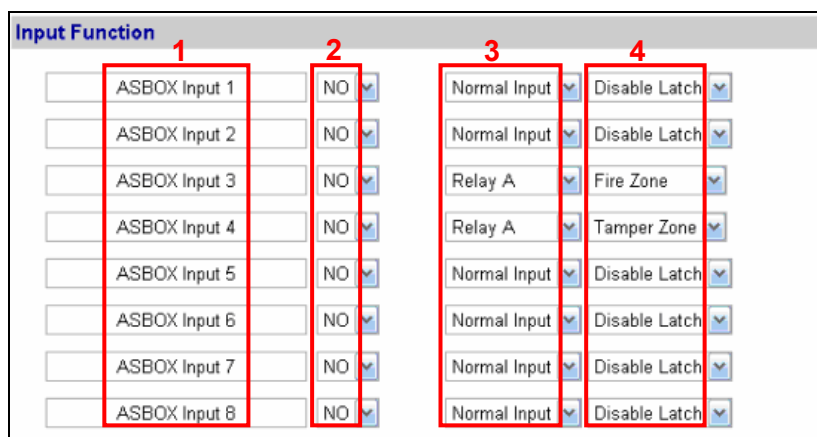

Figure 10-24

Below is the explanation based on the numbers marked on the above figure.

1. **ASBOX Input #:** Edit the name of the Input.
  2. **NO/NC:** Configure the input to **NC** (normally closed) or **NO** (normally open) mode.
  3. **Input Type:** Configure the input type to define the type of sensor that is connected to the input of GV-ASBox. Options available for the input type change based on your settings of **Door/Gate A** and **Door/Gate B** in the **Function Setting** page (Figure 10-15).
  4. **Input Function:** Configure the input function. Options available for the input function change based on the settings of **Input Type** above.
- When **Door Entry/Exit Control** is selected in the **Function Setting** page (Figure 10-15), these **Input Type** and **Input Function** become available:

Input Type	Input Function	Description
Normal Input	Enable Latch Disable Latch	The Normal Input is used for a normal detection mode in which the input is set to trigger an output. Instead of constant output alarm in N/O and N/C, the <b>Enable Latch</b> option provides a momentary alarm when triggered.
Door A or B	Fire Zone Tamper Zone Exit Button Door Contact	Depending on the type of sensor and the location where it is installed, select the best Input Function name to fit the sensor description. When the sensor is activated, an alarm event occurs and the alarm device can be triggered. For alarm events, see [Alarm], <i>9.3.2.B Parameter Setting</i> .  For example, when the <b>Door Contact</b> sensor detects unauthorized access, a “Force Open” event occurs and it can trigger the “Force Open” alarm.

- When **Parking Entry/Exit Control** is selected in the **Function Setting** page (Figure 10-15), these **Input Type** and **Input Function** become available:

Input Type	Input Function	Description
Normal Input	Enable Latch Disable Latch	See the same Input Type above.
Gate A or B	Fire Zone Tamper Zone Exit Button Car Detection	See the “Doo A or Door B” Input Type above.  For example, when the <b>Car Detection</b> sensor detects any car driving by, a “Parking Entry” or “Parking Exit” event occurs and the parking gate will respond the event accordingly.

- When **Elevator Control** is selected in the **Function Setting** page (Figure 10-15), these **Input Type** and **Input Function** become available:

Input Type	Input Function	Description
Normal Input	Enable Latch Disable Latch	See the same Input Type above.
Relay A or B	Fire Zone Tamper Zone	See the “Door A or Door B” Input Type above. For example, the <b>Tamper Zone</b> sensor is installed on GV-ASBox. So whenever there is any attempt to open the Box, the “Tamper” event occurs and it may trigger the “Tamper” alarm.

**Note:** For alarm outputs, the corresponding alarms must be enabled (YES) in the **Parameter Setting** page (Figure 10-16). If alarms are set to be disabled (NO), the alarm function here will not work when triggered.

### [Output Function]

Here you can define each output device that is connected to GV-ASBox, such as locking devices, various alarms or Exit Button. Only **Output 5 to Output 8** can be connected to Lights.

Select from the drop-down list to configure **Output Type** (No. 1, Figure 10-25). Depending on the chosen **Output Type**, either **Output Function** (No. 2, Figure 10-25) or **Output Conditions** (No. 3, Figure 10-25) will become available.

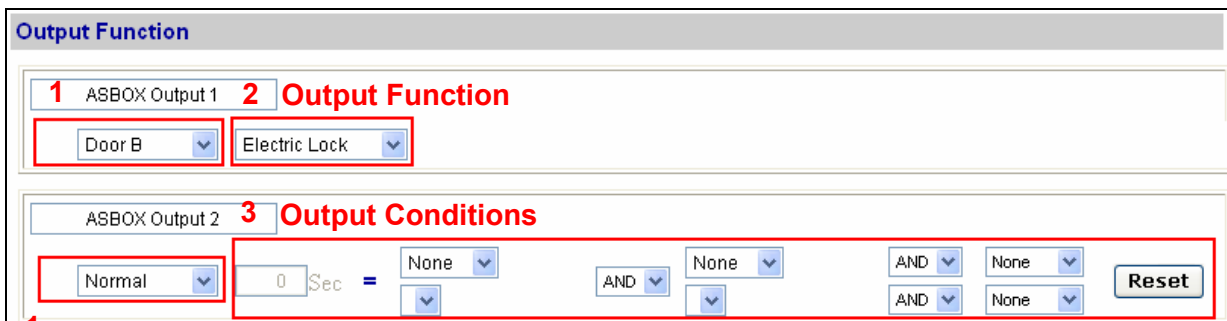

**Output Type**

Figure 10-25



**Output Function Settings:**

When **Output Type** (No. 1, Figure 10-25) is set to be **Door #**, **Gate #** or **Relay #**, the options similar to the figure below become available.

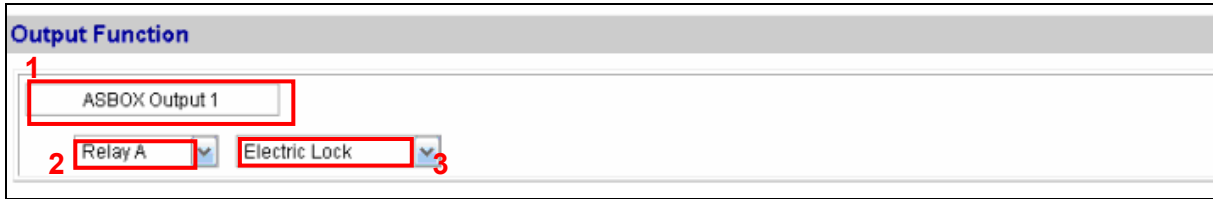

Figure 10-26

Below is the explanation based on the numbers marked on the above figure.

1. **ASBOX Output #:** Edit the name of the Output.
  2. **Output Type:** Configure the output type. Options available for the output type change based on your settings of **Door/Gate A** and **Door/Gate B** in the **Function Setting** page (Figure 10-15).
  3. **Output Function:** Configure the output function. Options available for the output function change based on your setting of **Output Type** above.
- When **Door Entry/Exit Control** is selected in the **Function Setting** page (Figure 10-15), these **Output Type** and **Output Function** become available:

Output Type	Output Function	Description
Door #	Electric Lock	Output is triggered when the card is presented to open the locking device.
	Alarm Event	Output is triggered when the defined alarm events occur.
	Entry Card	Output is triggered when the card is presented to enter the door.
	Exit Card	Output is triggered when the card is presented to exit the door.

- When **Parking Entry/Exit Control** is selected in the **Function Setting** page (Figure 10-15), these **Output Type** and **Output Function** become available:

Output Type	Output Function	Description
Gate #	Electric Lock	See the same function above.
	Alarm Event	
	Entry Card	Output is triggered when the card is presented to enter the parking gate.
	Exit Card	Output is triggered when the card is presented to exit the parking gate.

- When **Elevator Control** is selected in the **Function Setting** page (Figure 10-15), these **Output Type** and **Output Function** become available:

Output Type	Output Function	Description
Relay #	Electric Lock	See the same function above.
	Alarm Event	

**Output Condition Settings:**

When **Output Type** (No. 1, Figure 10-25) is set to be **Normal, Toggle, Pulse, Normal Lighting, Toggle Lighting** or **Pulse Lighting**, the options similar to the figure below become available.



**Available in  
Pulse/Lighting**

Figure 10-27

There can be a maximum of 4 conditions that can be set up to trigger an output. 2 conditions are Door/Gate/Relay conditions and 2 conditions are Input conditions. Each condition is related to each other through **AND/OR**. **AND** means that all conditions with **AND** must be triggered before the output is triggered. **OR** means that only 1 of the condition with **OR** is needed to be triggered before the output is triggered. It is also valid to have certain conditions as **AND** and certain conditions as **OR**.

Only **Output 5 ~ 8** can be connected to Lights. So **Normal Lighting, Toggle Lighting** and **Pulse Lighting** can only be selected from **Output 5 ~ 8**. For **Pulse** and **Pulse Lighting**, the output is triggered for the amount of time set in the **Sec** field (seconds).

In the Output Condition Settings, these **Output Type** and **Output Condition** options become available:

Output Type	Output Condition			
	Door A or B	Gate A or B	Relay A or B	Input (x2)
Normal	Access Granted	Access Granted	Access Granted	Select <b>None</b> to disable the condition, or select between Input 1 and Input 8 to trigger the output.
Toggle	Access Denied	Access Denied	Access Denied	
Pulse	Fire Alarm	Fire Alarm	Fire Alarm	
Normal Lighting	Tamper	Tamper	Tamper	
Toggle Lighting	Duress Event	Duress Event	Duress Event	
Pulse Lighting	Held Open	Held Open	/	
	Forced Open	Forced Open		
	Exit Button	Exit Button		
	Door Contact	Car Detection		

Click **Reset** button to return the **Normal, Toggle, Pulse, Normal Lighting, Toggle Lighting** or **Pulse Lighting** triggered state to be normal.

---

**Note:** The **Reset** button is more commonly used for the **Toggle** or **Toggle Lighting** output. Because once triggered, the output will go on forever. A **Reset** button is needed to turn it off.

---

Click **Submit** button to save the changes, or click **Cancel** button to return the changes to its previous state.

### 10.3.2.G Extended Reader

In the left menu, click **Extend Reader**. This **Extend Reader Configuration** page appears.

**Extend Reader Configuration**

**GV-Reader Function**

Serial Number	Function	Setting Status
<input type="checkbox"/> ID 0 <input type="text"/>	No Function	
<input type="checkbox"/> ID 1 <input type="text"/>	No Function	
<input type="checkbox"/> ID 2 <input type="text"/>	No Function	
<input type="checkbox"/> ID 3 <input type="text"/>	No Function	

**GeoFinger Function**

Serial Number	Function	Setting Status
<input type="checkbox"/> <input type="text"/>	No Function	
<input type="checkbox"/> <input type="text"/>	No Function	
<input type="checkbox"/> <input type="text"/>	No Function	
<input type="checkbox"/> <input type="text"/>	No Function	

**Submit** **Cancel**

Figure 10-28

Define the readers connected to GV-AS100 / 110 / 120, and then use the **Function** drop-down list to select which door that the GV-Reader/GV-GF Fingerprint Reader is installed.

#### [GV-Reader Function]

- **GV-RK1352 / R1352 / DFR1352:** Select the checkbox and type the **Serial Number** of the reader. Note that the ID number located next to the serial number field need to match the reader's ID number defined through the GV-RK1352 Config AP.
- **GV-Reader 1251 / Reader 1352 V2:** Select the checkbox and leave the serial number field blank. Note that the ID number located next to the serial number field need to match the reader's ID number defined by the dip switches on the reader.
- **GV-CR420:** Type the **Barcode** of GV-CR420. Select the checkbox only if the GV-CR420 is connected to the controller through RS-485 connection. For network connection, do not select the checkbox. Note that only GV-CR420 V1.0 is compatible with GV-AS100 / 110 / 120 and you must also enable network connection to the controller on the Web interface of the GV-CR420.

**[GeoFinger Function]** For **GV-GF1901 / GF1902 / GF1911 / GF1912**, select the checkbox and type the **XID Number** located on the back of the reader.

Click **Submit** to detect the readers. If any GV-Reader / GV-GF Fingerprint Reader is detected, a green mark will appear in the **Status** field; if not, a red mark will appear.

## **11. Troubleshooting**

## Q1: GV-ASManager cannot connect to GV-AS/ GV-EV Controller over the Internet.

There are several causes for this problem such as IP address conflict, incorrect connection settings and network failure. Follow the steps below to assign the fixed IP to the GV-ASManager and GV-AS / GV-EV Controller respectively. This procedure can determine if the problem is caused by the faulty devices and incorrect network settings.

1. Disconnect the hub or switch, which connects the GV-ASManager and GV-AS / GV-EV Controller, from the network.
2. Give the GV-ASManager a fixed IP address that is NOT used by another device, e.g. 192.168.0.154.

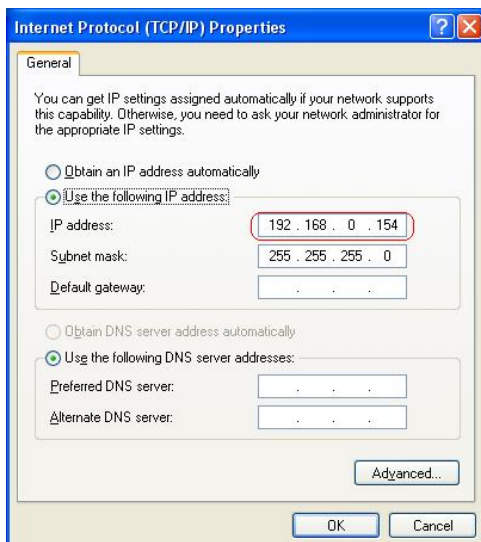

Figure 11-1

3. Reset the controller module and Ethernet module to factory defaults.
  - a. Plug the GV-ASKeypad to the controller.
  - b. Remove the jumper cap from the 2-pin **Default** jumper.
  - c. Press the **Reset** button.
  - d. Replace the jumper cap back to the 2-pin **Default** jumper.
  - e. To reset the Ethernet Module, press and hold the **Default EN** button for 6 seconds.



- Open the browser and enter the controller default address: <http://192.168.0.100>

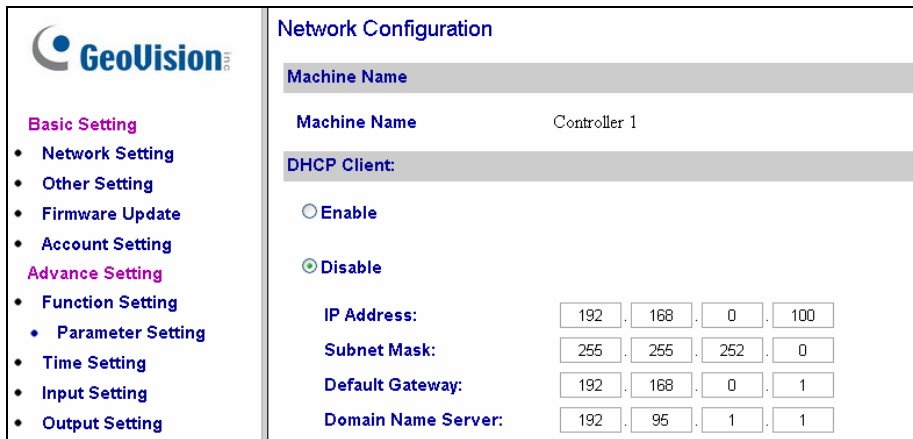

Figure 11-2

- In the IP address field, give the controller an IP address that is NOT used by another device, e.g. 192.168.0.XXX.
- On the GV-ASManager, enter the following settings:

**Controller ID:** 1

**Network:** TCP/IP

**IP:** 192.168.0.XXX

**Port:** 4000

**User:** admin

**Password:** admin

**Crypto key:** 12345678

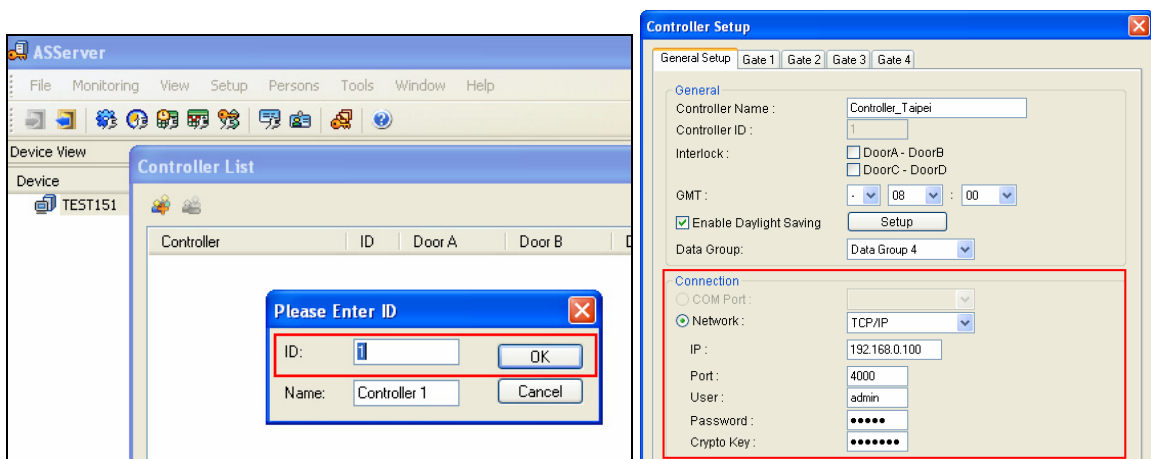



Figure 11-3

7. The connection between the GV-ASManager and controller should be established, and the connection icon  should appear. If disconnection happens after you connect the hub or switch to the network, then it should be other network problems. Please contact your network administrator.

## Q2: The connection established between the GV-ASManager and GV-AS / GV-EV Controller is interrupted.

This may be due to IP address conflict. Follow these steps to troubleshoot the problem:

1. Disconnect the hub or switch, which connects to the GV-ASManager and the controller, from the network.
2. Run Windows **Command Prompt**. Take Classic Windows Start Menu for example, click **Start**, select **Accessories** and click **Command Prompt**.
3. Type **arp -d** and press **Enter**.

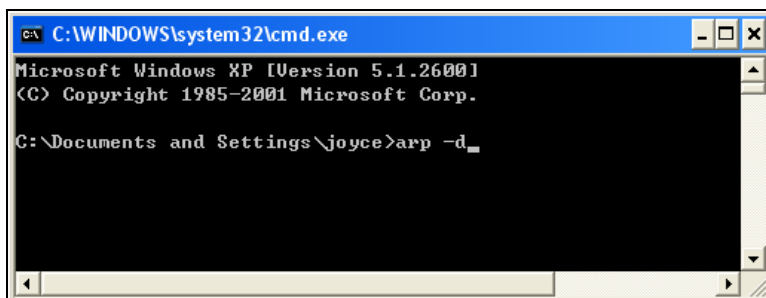

Figure 11-4

4. Give the GV-ASManager a fixed IP address that is NOT used by another device. See Figure 11-1.
5. Open the browser and enter the assigned IP address of the controller. The Network Configuration page appears. See Figure 11-2.
6. In the IP address field, give the GV-AS / GV-EV Controller an IP address that is NOT used by another device, e.g. 192.168.0.XXX.
7. On the GV-ASManager, enter the following settings. See Figure 11-3.

**Controller ID:** 1

**Network:** TCP/IP

**IP:** 192.168.0.XXX

**Port:** 4000

**User:** admin

**Password:** admin

**Crypto key:** 12345678

8. The connection between the GV-ASManager and GV-AS Controller should be established, and the connection icon  should appear. If disconnection happens after you connect the hub or switch to the network, then it should be other network problems. Please contact your network administrator.

**Q3: GV-ASManager cannot receive card messages but the reader accepts the card when the connection between the GV-ASManager and GV-AS / GV-EV Controller is well established.**

It may be due to memory failure in the GV-AS / GV-EV Controller. Reset both the controller module and the Ethernet module to factory settings. Refer to Step 3 in Question 1.

**Q4: The GV-ASManager cannot retrieve the video from the DVR for playback.**

1. Make sure the **Remote ViewLog Service** on **Control Center Server** is enabled on the DVR.
2. Make sure the time on the GV-ASManager and the DVR is consistent.
3. Make sure the event file you want to play back has been created completely on the DVR. For example, the assigned time length of every recorded event on the DVR is 5 minutes. The desired event of 5 minutes must have been displayed on the ViewLog Event List, so you can access the event file for playback.

**Q5: After I add a card by presenting to the reader, the message “Access Denied Invalid Card” still appears.**

It may be the card format is not compatible with the GV-AS / GV-EV Controller. Make sure the card format is 26~64 bits. Otherwise, send us the related information of your card format so that we can customize the format for you.

**Q6: The GV-ASManager cannot receive card messages from the GV-Reader connected to the GV-AS / GV-EV Controller through RS-485 interface.**

1. Make sure the GV-Reader is correctly wiring to the controller and Switch 4 on the GV-Reader is set to OFF.
2. Make sure the correct GV-Reader ID is set on the controller.

**Q7: I can't change the Advanced Settings on the Web interface of the GV-AS / GV-EV Controller. The "Submit" button is missing.**

To modify the Advanced Settings, make sure the **Web Setting Switch** on the controllers is set to ON. For the location of the Web Setting Switch, refer to the *Web Setting Switch* section of each GV-AS / GV-EV Controller or GV-ASNet / GV-ASBox.

**Q8: After installing GV-ASManager, the message "d3dx9\_40.dll cannot be found" appears.**

Make sure DirectX End-User Runtimes is installed and restart the computer afterwards. To install DirectX End-User Runtimes, insert the supplied Software DVD to your computer, and select **Install DirectX End-User Runtimes (November 2008)**.

**Q9: How can I find more help?**

Visit our website at <http://www.geovision.com.tw>

Write to us at [support@geovision.com.tw](mailto:support@geovision.com.tw)