

EM1000U Series Mount

CEILING/PEDESTAL/WALL MOUNT, MEDIUM DUTY, ENCLOSURE

Product Features

- Adjustable Swivel Head
- Supports up to 40 lb (18.14 kg)
- Cable Feedthrough Holes Conceal Wiring
- Accommodates Medium Duty Pelco Enclosures with 2-Inch (5.08 cm) Mounting Hole Pattern
- Ceiling, Pedestal, or Wall Mounting



The **EM1009U/EM1015U/EM1900U** are medium duty enclosure mounts capable of supporting loads up to 40 lb (18.14 kg). Designed for ceiling/pedestal and wall applications, these versatile mounts can be used with Pelco enclosures having a 2-inch (5.08 cm) mounting hole pattern.

The **EM1009U/EM1015U** are ceiling/pedestal mounts and the **EM1900U** is a 90-degree wall mount. The ceiling/pedestal mounts are available in two lengths: 10 inches (24.89 cm) (**EM1009U**) and 16 inches (40.13 cm) (**EM1015U**). The **EM1900U** extends 15 inches (38.18 cm) from the wall to allow unlimited positioning of the enclosure.

Constructed of aluminum, all three mounts feature an adjustable swivel head, which allows mechanical positioning of the enclosure. In addition, there is a 1-inch (2.54 cm) diameter cable feedthrough hole and openings in the top and bottom to conceal the wiring.



TECHNICAL SPECIFICATIONS

MODELS

EM1009U	Universal medium duty ceiling/pedestal mount with manually adjustable swivel head, 10-inch (24.89 cm) length
EM1015U	Universal medium duty ceiling/pedestal mount with manually adjustable swivel head, 16-inch (40.13 cm) length
EM1900U	Universal medium duty 90° wall mount with manually adjustable swivel head; extends 15 inches (38.18 cm) from wall

MECHANICAL

Pan Adjustment	360°
Tilt Adjustment	75° (up or down)

GENERAL

Enclosure Mounting	Two 1/4-20 mounting bolts (supplied)
Suggested Mounting Method	Secure to solid surface with a minimum of two 1/4-20 fasteners (not supplied). (For maximum stability use four fasteners.)
Cable Feedthrough	One 1-inch (2.54 cm) diameter hole at base of mount
Maximum Load	40 lb (18.14 kg)
Locking Method	3/8-16 hex head bolts on adjustable swivel head
Construction	Aluminum
Finish	Gray polyester powder coat
Unit Weight	
EM1009U	1.98 lb (0.90 kg)
EM1015U	2.43 lb (1.10 kg)
EM1900U	2.83 lb (1.28 kg)
Shipping Weight	
EM1009U	3 lb (1.35 kg)
EM1015U	5 lb (2.26 kg)
EM1900U	5 lb (2.26 kg)

CERTIFICATIONS

- UL Listed

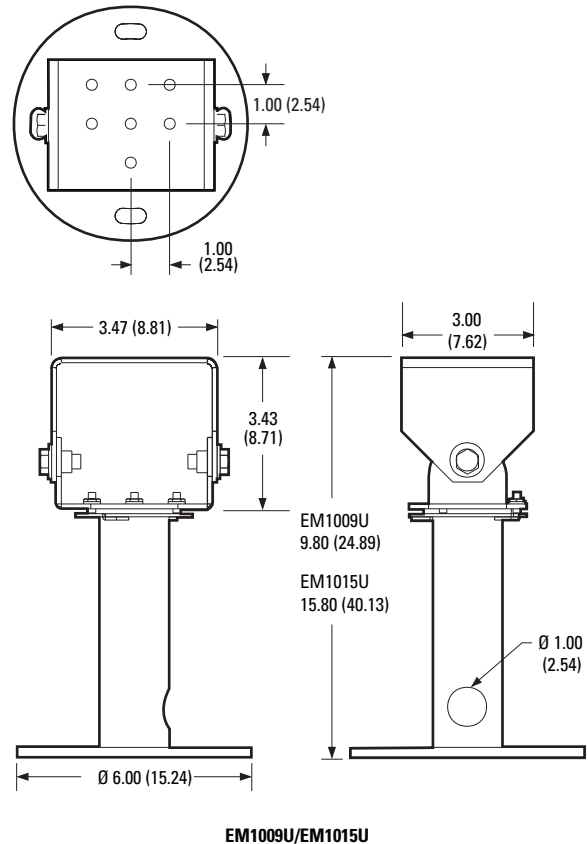
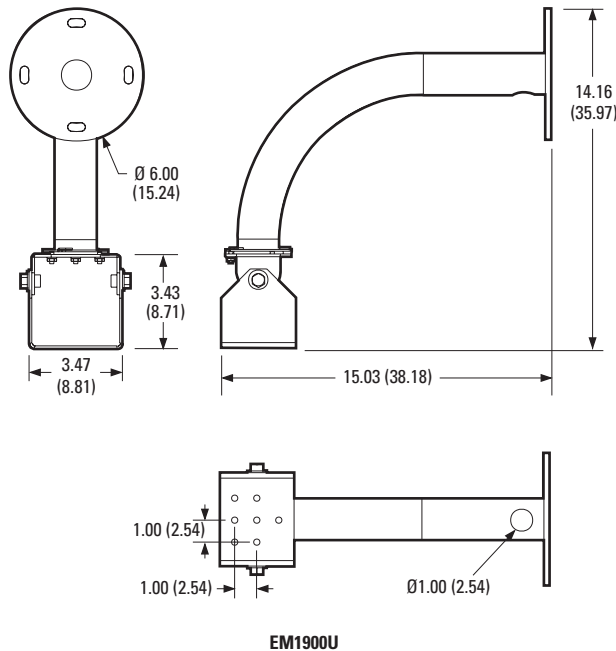

NOTE: VALUES IN PARENTHESES ARE CENTIMETERS; ALL OTHERS ARE INCHES.



Pelco, Inc. Worldwide Headquarters:
 3500 Pelco Way, Clovis, California 93612-5699 USA
USA & Canada Tel: (800) 289-9100 • FAX: (800) 289-9150
International Tel: +1 (559) 292-1981 • FAX: +1 (559) 348-1120
www.pelco.com

Pelco and the Pelco logo are registered trademarks of Pelco, Inc.
 Product specifications and availability subject to change without notice.
 ©Copyright 2008, Pelco, Inc. All rights reserved.